

BD FACSAria User's Guide

<http://www.bdbiosciences.com/>
Part No. 333608 Rev. A
March 2003



BD Biosciences
2350 Qume Drive
San Jose, CA 95131-1807
USA
Tel (877) 232-8995
Fax (408) 954-2347

Asia Pacific
Tel (65) 6-861-0633
Fax (65) 6-860-1590

Europe
Tel (32) 53-720211
Fax (32) 53-720450

Brazil
Tel (55) 11-5185-9995
Fax (55) 11-5185-9895

Japan
Nippon Becton Dickinson Company, Ltd.
Tel 0120-8555-90

Canada
Tel (888) 259-0187
(905) 542-8028
Fax (905) 542-9391
canada@bd.com

Mexico
Tel (52) 55 5999 8296
Fax (52) 55 5999 8288

© 2003, Becton, Dickinson and Company. All rights reserved. No part of this publication may be reproduced, transmitted, transcribed, stored in retrieval systems, or translated into any language or computer language, in any form or by any means: electronic, mechanical, magnetic, optical, chemical, manual, or otherwise, without prior written permission from BD Biosciences.

The information in this guide is subject to change without notice. BD Biosciences reserves the right to change its products and services at any time to incorporate the latest technological developments. Although this guide has been prepared with every precaution to ensure accuracy, BD Biosciences assumes no liability for any errors or omissions, nor for any damages resulting from the application or use of this information. BD Biosciences welcomes customer input on corrections and suggestions for improvement.

BD, the BD logo, BD CaliBRITE, BD CellQuest, BD FACS, BD FACSAria, BD FACSCalibur, BD FACSConvert, BD FACSRinse, BD FACStation, BD FACSvantage, and BD Falcon, are trademarks of Becton, Dickinson and Company.

Texas Red is a trademark of Molecular Probes, Inc. Clorox is a registered trademark of The Clorox Company. Innova is a registered trademarks of COHERENT, INC. FlowJo is a trademark of Tree Star, Inc. Java is a trademark of Sun Microsystems, Inc in the US and other countries. Microsoft and Windows are registered trademarks of Microsoft Corporation. Q-tips is a registered trademark of Chesebrough-Pond's Inc. Teflon is a registered trademark of E.I. du Pont de Nemours and Company. Windex is a registered trademark of the Drackett Products Company.

All other company and product names might be trademarks of the respective companies with which they are associated.

Guide written by Kim Gautho; edited by Joan Miller; produced by Pushpa MacFarlane.

Regulatory Information

For Research Use Only. Not for use in diagnostic procedures.

WARNING: Changes or modifications to this unit not expressly approved by the party responsible for compliance could void the user's authority to operate the equipment.

NOTE: This equipment has been tested and found to comply with the limits for a Class A digital device, pursuant to Part 15 of the FCC Rules. These limits are designed to provide reasonable protection against harmful interference when the equipment is operated in a commercial environment. This equipment generates, uses, and can radiate radio frequency energy and, if not installed and used in accordance with the instruction manual, may cause harmful interference to radio communications. Operation of this equipment in a residential area is likely to cause harmful interference in which case the user will be required to correct the interference at his or her own expense.

Shielded cables must be used with this unit to ensure compliance with the Class A FCC limits.

This Class A digital apparatus meets all requirements of the Canadian Interference-Causing Equipment Regulations.

Cet appareil numérique de la classe A respecte toutes les exigences du Règlement sur le matériel brouilleur du Canada.

History

Revision	Date	Change Made
333608	1/03	Initial release

Contents

About This Guide	ix
Conventions	x
Technical Assistance	xi
Safety and Limitations	xiii
Laser Safety	xiii
Laser Classification	xiv
Precautions for Safe Operation	xiv
Electrical Safety	xv
Biological Safety	xvi
General Safety	xvii
Precaution Labels	xvii
Limitations	xix
Chapter 1: BD FACSAria Instrument Components	21
Fluidics Cart	22
Containers and Connectors	23
Power and Operation	25
Flow Cytometer	26
Fluidics Components	27
Optics System	36
Instrument Electronics	41
BD FACSAria Workstation	44

Chapter 2: Theory of Operation	45
Fluid Movement	46
Sheath Flow	46
Sample Flow	47
Signal Generation	49
Light Scatter	49
Fluorescent Signal	50
Signal Detection	51
Detector Arrays	51
Filters	52
Detectors	56
Electronic Processing	57
Pulse Parameters	58
Laser Delay	59
Sorting	60
Drop Formation	61
Side-Stream Formation	65
Particle Charging	68
Conflict Resolution During Sorting	69
 Chapter 3: Using BD FACSDiVa Software	 77
Workspace Components	78
Instrument Controls	79
Fluidics Controls	80
Fluidics Level Indicators	83
Instrument Configuration	84
Instrument Status Report	85
Acquisition Controls	86

Sorting Controls	87
Sort Menu	88
Sort Setup	89
Sort Layout	90
Sort Report	97
Chapter 4: Running Samples	99
Starting Up the Instrument	100
Setting Up the Fluidics Cart	102
Instrument Quality Control	105
Setting Up the Experiment	105
Verifying Area Scaling and Laser Delay	112
Reusing the Experiment	120
Sample Optimization Using Instrument Setup	121
Creating the Experiment	122
Adjusting the Voltages and Threshold	124
Calculating Compensation	127
Recording and Analyzing Data	129
Setting Up the Acquisition Template	129
Recording Data	131
Analyzing Data	132
Reusing the Analysis	135
Saving the Analysis	135
Chapter 5: Sorting	137
Setting Up for Sorting	138
Changing the Nozzle	140
Setting Up the Breakoff	142
Setting Up for Bulk Sorting	143
Calculating the Drop Delay	145
Setting Up the Experiment	145
Sorting Beads to Determine the Drop Delay	146

Sorting	149
Setting Up the Experiment	149
Starting and Monitoring the Sort	151
Setting Up for Sorting Into a Plate or Slide	153
Installing the Sorting Hardware	153
Setting Up the Stream	155
Creating a Custom Device	158
Chapter 6: DNA Analysis	161
Criteria for DNA Experiments	162
CEN Optimization	163
Setting Up the Experiment	164
Running CEN	166
CTN Resolution	168
Running CTN	168
Running Test Samples	170
Chapter 7: Shutdown and Maintenance	171
Daily Shutdown	172
Fluidics Shutdown	172
External Cleaning	174
Scheduled Maintenance	177
Internal Cleaning	178
Purging Filters	191
Changing Fluid Filters	192
Changing the Sample Lines	192
Changing Air Filters	196
Unscheduled Maintenance	196
Cleaning a Nozzle	197
Cleaning the Camera Optics	199
Cleaning Optical Filters	200

Chapter 8: Troubleshooting	201
Troubleshooting the Stream	202
Fluidics Troubleshooting	206
Electronics Troubleshooting	207
Acquisition Troubleshooting	208
Sorting Troubleshooting	214
Appendix A: Supplies and Options	217
Instrument Supplies	218
Optical Components	218
Accessory Kit	219
Other Replacement Parts	221
Consumables	222
Instrument Setup Particles	222
Reagents	223
Labware	224
Instrument Options	225
Application Options	226
Two-Laser System	226
Three-Laser System	227
Changing Filters	228
Defining a New Configuration	230
Index	233

About This Guide

This user's guide contains the instructions necessary to operate and maintain your BD FACSAria™ flow cytometer. Because many instrument functions are controlled by BD FACSDiVa™ software, this guide also contains basic software information needed for instrument setup. For more detailed instructions on how to use the software, refer to the *BD FACSDiVa Software User's Guide*.

The *BD FACSAria User's Guide* assumes you have a working knowledge of basic Microsoft® Windows® operation. If you are not familiar with the Windows operating system, refer to the documentation provided with your computer.

New users of the BD FACSAria flow cytometer should read:

- Chapter 1 to become familiar with your instrument components
- Chapter 2 to understand how the instrument works and to learn about the software components used to control different subsystems
- Chapter 3 to see where software components are located

Instructions for routine acquisition, analysis, and sorting can be found in Chapters 4 and 5. For information about running DNA samples, see Chapter 6.

Once you become familiar with routine operation and need only a quick reminder of the main steps, use the quick reference guide located in the front pocket of this user's guide.

Conventions

The following tables list conventions used throughout this guide. Table 1 lists the symbols that are used to alert you to a potential hazard. The word accompanying the hazard symbol indicates the level of severity, as shown in Table 2. Text and keyboard conventions are shown in Table 3.

Table 1 Hazard icons





Symbol	Hazard	Symbol	Hazard
	Dangerous voltage		Highly flammable
	Laser radiation		General
	Biological risk		

Table 2 Severity indicators^a

Indicator	Level of Severity
WARNING	The hazard or unsafe practice could result in severe injury or death.
CAUTION	The hazard or unsafe practice could result in minor injury.
NOTICE	The hazard or unsafe practice could result in a possibly dangerous situation; material could be damaged or data could be lost.

a. In compliance with the ANSI Z535.4 standard: Product Safety Signs and Labels

Table 3 Text and keyboard conventions

Convention	Use
☑ Tip	Highlights features or hints that can save time and prevent difficulties
<i>Italics</i>	Italics are used to highlight book titles and new or unfamiliar terms on their first appearance in the text.
>	The arrow indicates a menu choice. For example, “choose File > Print” means to choose Print from the File menu.
Ctrl-X	When used with key names, a dash means to press two keys simultaneously. For example, Ctrl-P means to hold down the Control key while pressing the letter <i>p</i> .

Technical Assistance

For technical questions or assistance in solving a problem:

- Read the section of the user’s guide specific to the operation you are performing.
- See Chapter 8, Troubleshooting.

If additional assistance is required, contact your local BD Biosciences technical support representative or supplier.

When contacting BD Biosciences, have the following information available:

- product name, part number, and serial number
- any error messages
- details of recent system performance

For instrument support from within the US, call (877) 232-8995, prompt #2-2.

For support from within Canada, call (888) 259-0187.

Customers outside the US and Canada, contact your local BD representative or distributor.

Safety and Limitations

The BD FACSAria™ flow cytometer is equipped with safety features for your protection. Operate the instrument only as directed in the user's guide. Keep this safety information available for future reference and for new users.

Laser Safety

Lasers or laser systems emit intense, coherent electromagnetic radiation that has the potential of causing irreparable damage to human skin and eyes. The main hazard of laser radiation is direct or indirect exposure of the eye to thermal radiation from the visible and near-infrared spectral regions (325–1,400 nm). Direct eye contact can cause corneal burns, retinal burns, or both, and possible blindness.

There are other potentially serious hazards in other spectral regions. Excessive ultraviolet exposure produces an intolerance to light (photophobia) accompanied by redness, a tearing discharge from the mucous membrane lining the inner surface of the eyelid (conjunctiva), shedding of the corneal cell layer surface (exfoliation), and stromal haze. These symptoms are associated with photokeratitis, otherwise known as snow blindness or welder's flash, which results from radiant energy–induced damage to the outer epidermal cell layer of the cornea. These effects can be the result of laser exposure lasting only a fraction of a second.

Laser Classification

Laser hazard levels depend on laser energy content and the wavelengths used. A numbered system is used to categorize lasers according to different hazard levels. The higher the classification number, the greater the potential hazard. The BD FACSAria flow cytometer is a Class I laser product per 21 CFR Subchapter J and EN 60825-1:1994 + A2:2001. The lasers are fully contained within the instrument structure and call for no special work area safety requirements except during service procedures. These procedures are to be carried out only by BD Biosciences service personnel.

Precautions for Safe Operation

 **WARNING** Modification or removal of the optics covers or laser shielding could result in exposure to hazardous laser radiation. To prevent irreparable damage to human skin and eyes, do not remove the optics covers or laser shielding, adjust controls, or attempt to service the instrument any place where laser warning labels are attached (see Precaution Labels on page xvii).

 **CAUTION** Controls, adjustments, or performance of procedures other than those specified in the *BD FACSAria User's Guide* can result in exposure to hazardous visible or ultraviolet laser radiation, or both.

 **CAUTION** Keep all instrument doors closed during instrument operation. When operated under these conditions, the instrument poses no danger of exposure to hazardous laser radiation.

Electrical Safety

 **WARNING** Lethal electrical hazards are present in some lasers, particularly in laser power supplies. Many portions of the electrical system, including the printed circuit boards, are at a dangerous voltage level. To prevent shock injury, follow these guidelines.

- Connect the equipment only to an approved power source. Do not use extension cords. Have an electrician immediately replace any damaged cords, plugs, or cables.
- Do not remove the grounding prong from the power plug. Have a qualified electrician replace any ungrounded receptacles with properly grounded receptacles in accordance with the local electrical code.
- Do not perform instrument maintenance or service procedures except as specifically stated in the user's guide.

 **WARNING** A 12,000-volt potential exists between the deflection plates when they are on. Contact with the charged plates results in serious electrical shock. Do not touch the deflection plates when the voltage warning light is illuminated, or when the software indicates that the plate voltage is on. The plates remain energized even when the sort block door is opened.

 **CAUTION** The nozzle and the stream-charging wire conduct electrical charge during sorting. To prevent shock, do not touch the nozzle or the stream-charging wire when the voltage warning light is illuminated or any time during sorting.

Biological Safety

 **WARNING** All biological specimens and materials coming into contact with them can transmit potentially fatal disease. To prevent exposure to biohazardous agents, follow these guidelines.

- Handle all biological specimens and materials as if capable of transmitting infection. Dispose of waste using proper precautions and in accordance with local regulations. Never pipette by mouth. Wear suitable protective clothing, eyewear, and gloves.
- Expose waste container contents to bleach (10% of total volume) before disposal. Dispose of waste in accordance with local regulations. Use proper precaution and wear suitable protective clothing, eyewear, and gloves.
- Prevent waste overflow by emptying the waste container daily or whenever the waste indicator shows the waste is getting full.

 **WARNING** Cell sorters that use droplet generation methods, like the BD FACSAria, can produce aerosols around the sample stream. When acquiring biohazardous samples, follow universal precautions at all times. Keep the sort block door closed during sorting. If you need to access the sort block, turn off the stream before opening the door.

For information on laboratory safety, refer to the following guidelines. NCCLS documents can be ordered online at www.nccls.org.

- Schmid I, Nicholson JKA, Giorgi JV, et al. Biosafety guidelines for sorting of unfixed cells. *Cytometry*. 1997;28:99-117.
- *Protection of Laboratory Workers from Instrument Biohazards and Infectious Disease Transmitted by Blood, Body Fluids, and Tissue; Approved Guideline*. Wayne, PA: National Committee for Clinical Laboratory Standards, 1997. NCCLS document M29-A.
- *Procedures for the Handling and Processing of Blood Specimens; Approved Guideline*. Wayne, PA: National Committee for Clinical Laboratory Standards; 1990. NCCLS document H18-A.

General Safety





⚠ CAUTION Movement of mechanical parts within the instrument can pinch or injure your hands or fingers. To prevent injury by moving parts, follow these precautions.



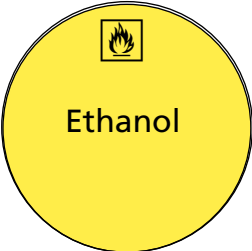

- Keep your hands and clothing away from the sample injection chamber when a tube is loading or unloading. Do not place objects underneath the sample injection chamber.
- Keep your hands away from the sort aspirator drawer during sorting. The drawer can close at any time without warning if a clog is detected during sorting.
- When sorting into a plate, keep the sort collection chamber door closed during sorting. Do not place objects inside the sort collection chamber, and do not attempt to access the plate until sorting is complete. The microtiter tray stage can move suddenly during the sorting process. Sorting continues even when the sort collection chamber door is opened.

Precaution Labels

The following precaution labels appear on the BD FACSAria flow cytometer or fluidics cart to indicate a potential hazard. Do not remove these labels. Use appropriate precaution to avoid injury by the indicated hazard. See the previous sections in this booklet for more information.

Label	Location(s)	Potential Hazard
 Waste	Waste tank, waste tank connectors on fluidics cart	Risk of exposure to biologically transmissible disease

Label	Location(s)	Potential Hazard
	Waste tank cap	Risk of exposure to biologically transmissible disease
	Ethanol tank, ethanol tank connectors on fluidics cart	Highly flammable material
	Ethanol tank cap	Highly flammable material
	Deflection plates indicator light	Dangerous voltage
	Sort block door where deflection plates can be accessed (inside and outside)	Dangerous voltage

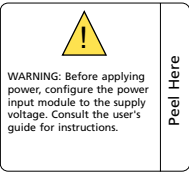
Label	Location(s)	Potential Hazard
 	<p>On or near all removable covers and any place where the laser beam can emerge from the instrument</p>	<p>Risk of exposure to hazardous laser radiation</p>
	<p>Behind sample injection chamber</p>	<p>Risk of crushing or pinching by moving parts</p>
	<p>Floor of sort collection chamber</p>	<p>Risk of crushing or pinching by moving parts</p>
	<p>Power input on fluidics cart</p>	<p>Risk of instrument damage if wrong voltage applied^a</p>

a. NOTE: Voltage is set by your service engineer during installation.

Limitations

This instrument is for Research Use Only. Not for use in diagnostic or therapeutic procedures.

BD FACSAria Instrument Components

The BD FACSAria flow cytometer is the first fixed-alignment benchtop high-speed cell sorter. The instrument can be operated at varied pressures and can acquire up to 70,000 events per second. With its fixed-optics design and digital electronics, the BD FACSAria flow cytometer enables multicolor analysis of up to 13 fluorescent markers and two scatter parameters at a time.

The BD FACSAria system consists of three major components: a fluidics cart, a benchtop flow cytometer, and the BD FACSAria workstation (see Figure 1-1 on page 22). Nearly all instrument functions are operated from within BD FACSDiVa software.

For a description of the BD FACSAria system components, see the following sections. For technical information about how the instrument works, see Chapter 2.

- Fluidics Cart on page 22
- Flow Cytometer on page 26
- BD FACSAria Workstation on page 44

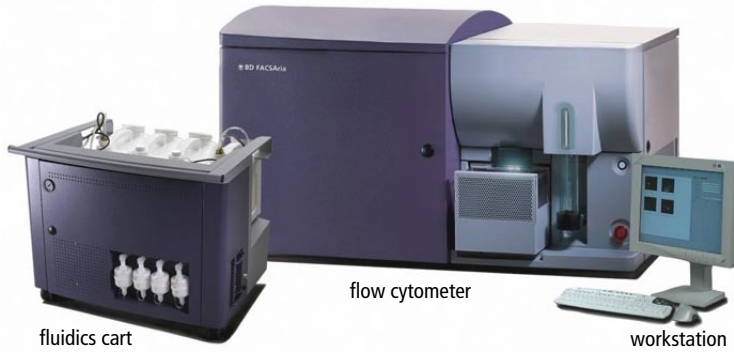

Figure 1-1 BD FACSAria instrument components

Fluidics Cart

A separate fluidics cart supplies sheath and cleaning fluids and collects waste from the instrument (Figure 1-2). The self-contained fluidics cart supplies the required air pressure and vacuum, which eliminates the need for an external source (although the cart can be hooked up to an in-house air source, if one is available). The air pumps provide pressure from 2 to 75 psi to accommodate a variety of cell sorting applications. Air pressure is adjusted within BD FACSDiVa software.



Figure 1-2 Fluidics cart

Containers and Connectors

The fluidics cart holds four 10-L containers (two sheath and two waste), and three 5-L auxiliary cleaning fluid containers (Figure 1-3). All containers, caps, level sensors, and tubing are autoclavable. The cart can also accommodate up to two BD FACSTFlow™ 20-L cubitainers in place of the four 10-L containers.



Figure 1-3 Fluidics cart containers

The fluidics cart connects directly to the flow cytometer unit via a power cord, fluid hoses, and air line (Figure 1-4 on page 24). Receptacles for the aerosol management and temperature control options are also located within the connection panel. The position of the fluidics cart is constrained only by the length of the power cord and fluidics hoses, which extend up to 8 feet (2.4 m). Typically, the cart is placed to the left or underneath the cytometer.

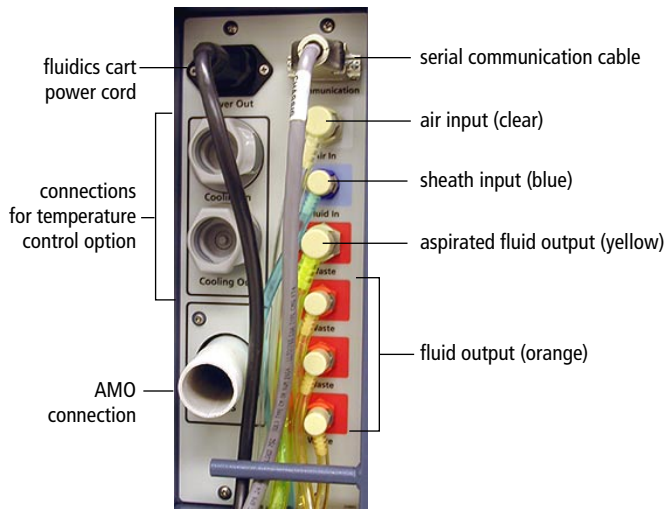

Figure 1-4 Fluidics cart power and tubing line connectors

To connect the fluidics cart to an external air source, open the shutter above the Communication port on the fluidics cart, flip the Auxiliary Air Supply switch to On, and attach the external air line to the air input connector.



NOTICE The external air supply should provide 80–100 psi.

Power and Operation

Power to the fluidics cart is supplied by the cytometer—the cart’s fluid pumps are activated when the cytometer main power switch is turned on. (See Power Panel on page 42.)

⚠ NOTICE Power to the fluidics cart is supplied and controlled through the flow cytometer. The fluidics cart voltage settings have been configured to match the supply voltage by your service engineer. To properly operate the fluidics cart, plug the fluidics cart power cord only into the power receptacle on the instrument (Figure 1-4 on page 24). Do not plug the power cord directly into a wall socket. Do not change the input voltage selection jumpers on the fluidics cart fuse holder.

⚠ NOTICE When the stream is on, air pressure fluctuates between 80–100 psi (Figure 1-5). A pressure reading of less than 80 psi or greater than 100 psi indicates that the fluidics cart is not functioning properly. If this occurs, contact your BD Biosciences service representative for assistance. Do not operate the instrument outside the normal air pressure range.



Figure 1-5 Fluidics cart flow gauge

See the following sections for more information about the fluidics cart.

- Setting Up the Fluidics Cart on page 102
- Refilling Containers on page 103
- Emptying the Waste on page 104

- Scheduled Maintenance on page 178
- Fluidics Cart Troubleshooting on page 219

Flow Cytometer

The benchtop flow cytometer contains the major components for all three subsystems (fluidics, optics, and electronics). The BD FACSAria instrument is relatively compact, with a much smaller footprint than most sorters with the same capabilities. The instrument can be set up on a typical laboratory benchtop or table, and it requires only a standard electrical outlet. No special facilities are required.

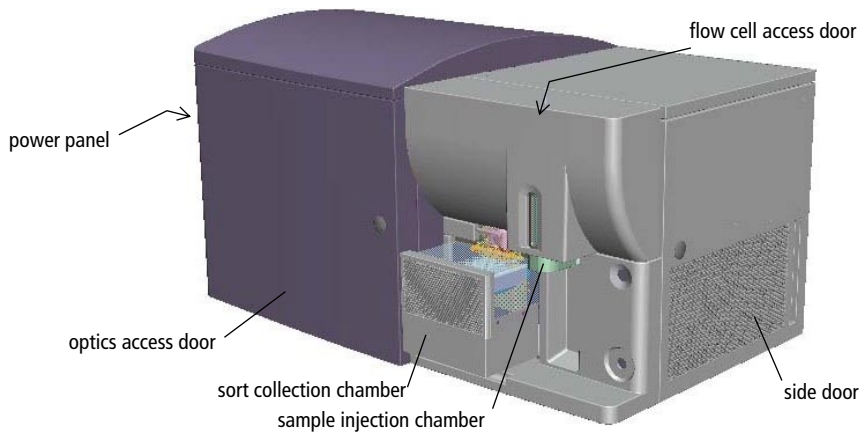

Figure 1-6 BD FACSAria flow cytometer

To view the fluidics components, open the side door and lift the flow cell access door; to view the optics components, open the optics access door. The power panel and connectors are found on the left side of the instrument. Other electronic components are embedded within the instrument and do not need user adjustment.

⚠ NOTICE The flow cell access door is equipped with a shutter mechanism that shuts off the laser light when the door is opened. To prevent data loss, do not open the door during sample acquisition or sorting.

See the following sections for more information about the flow cytometer.

- Fluidics Components on page 27
- Optics System on page 36
- Instrument Electronics on page 41

Fluidics Components

When the fluidics system is activated, sheath fluid is pumped from the fluidics cart into a plenum reservoir where the fluidics system is pressurized. From the reservoir, fluid is pumped into the cuvette flow cell where hydrodynamic focusing forces particles from the sample injection chamber through the cuvette in a single-file stream.

Within the cuvette flow cell, laser light is focused on the sample core stream. Fluorescent molecules excited by the different laser wavelengths are detected by the optics and analyzed by the electronics. Particles are then either transported to waste reservoirs via the waste aspirator, or sorted into a receptacle within the sort collection chamber.

The following fluidics components are described in this section. For more information about fluidics, see Fluid Movement on page 46.

- Plenum Reservoir on page 28
- Sample Injection Chamber on page 29
- Cuvette Flow Cell on page 30
- Nozzle on page 31
- Sort Block on page 32
- Sort Collection Chamber on page 35

Plenum Reservoir

Sheath fluid is pumped from the fluidics cart into a plenum reservoir inside the side door of the BD FACSAria flow cytometer (Figure 1-7). The plenum reservoir holds the sheath fluid until it is pumped into the cuvette flow cell. It eliminates pressure fluctuations by maintaining fluid levels and filtering out pump pulsation. As a result, the fluidics pressure does not vary with the level of fluid in the sheath containers.

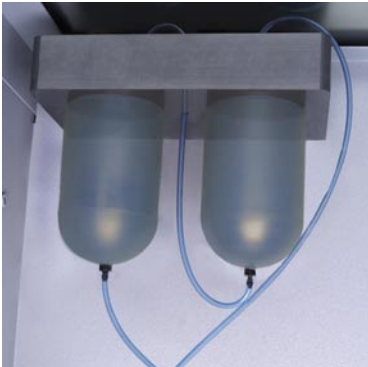

Figure 1-7 Plenum reservoir

Note that the plenum tanks can be unscrewed and removed for autoclaving or cleaning, if needed. See *Cleaning the Plenum Reservoirs* on page 185 for more information.

Sample Injection Chamber

The sample injection chamber is where sample is introduced into the flow cytometer. During acquisition, the chamber is pressurized to force sample toward the cuvette flow cell.

Samples can be agitated and temperature-controlled within the sample injection chamber using controls in the software (see Fluidics Controls on page 80). You can view the amount of fluid remaining in your sample tube by pressing the chamber light button shown in Figure 1-8.

NOTICE Do not use the chamber light with samples stained with light-sensitive reagents.

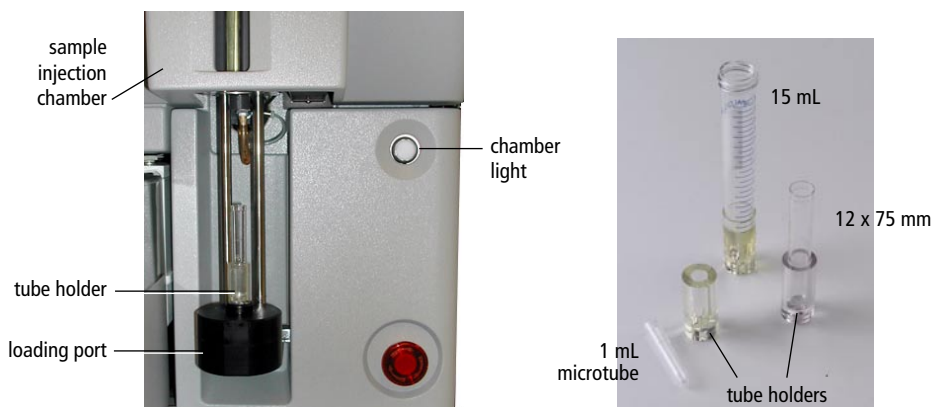

Figure 1-8 Sample injection chamber and tube holders

A variety of tube holders are provided with the instrument to accommodate tubes from 15-mL centrifuge tubes to 1.0-mL microtubes (Figure 1-8). (For a list of compatible tubes, see Labware on page 230.) To load a tube, install the appropriate-size tube holder in the loading port, and place a tube in the holder. When the Load button is clicked in the software (see Acquisition Controls on page 86), the loading port rises to enclose the tube within the chamber.

After a tube is loaded, the Load button changes to Unload. Use the Unload button to lower the loading port after data has been recorded. After each tube is unloaded, sheath fluid flushes the sample tubing inside and out to reduce

potential sample carryover. Using a special cleaning mode, the entire sample injection chamber can be decontaminated with ethanol. See Clean Bulk Injection Chamber on page 186 for more information.

Cuvette Flow Cell

The cuvette flow cell is the heart of the BD FACSAria instrument (Figure 1-9). Within the flow cell, hydrodynamic focusing forces particles through the cuvette in a single-file stream, where laser light intercepts the stream at the sample interrogation point.

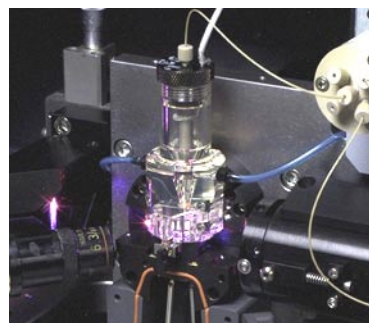
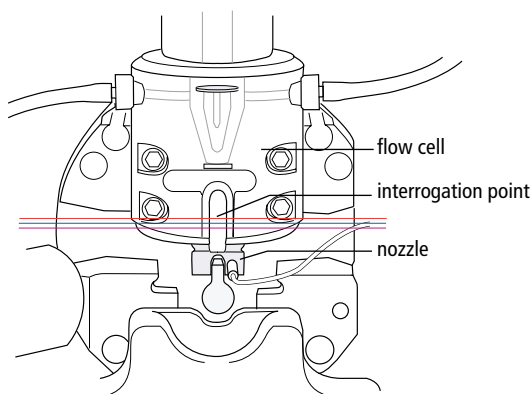

laser light intercepting flow cell

Figure 1-9 Cuvette flow cell

The unique flow cell design permits particles to flow through the cuvette at a low velocity, allowing longer exposure to laser energy. The cuvette is gel-coupled to the fluorescent objective lens to transmit the greatest amount of emitted light from the interrogation point to the collection optics (see Optics System on page 36). After passing through the cuvette, the stream is accelerated as it enters the nozzle tip, where the drop drive breaks the stream into droplets for sorting.

Nozzle

The BD FACSAria instrument is provided with two nozzles, 70 and 100 μm , that accommodate a variety of particle sizes (Figure 1-10). The nozzle is keyed to a fixed position at the end of the cuvette, as shown in Figure 1-9. Because the nozzle is below the interrogation point, optical alignment is not affected when the nozzle is changed.

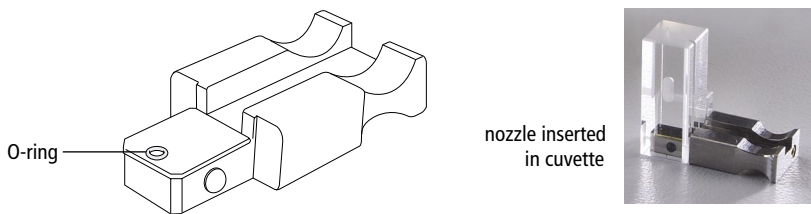

Figure 1-10 Nozzle

- Tip** When changing the nozzle, do not dislodge the nozzle O-ring as you remove or insert the nozzle into the cuvette. For instructions, see *Changing the Nozzle* on page 140.
- CAUTION** The nozzle and its attached stream-charging wire conduct electrical charge during sorting. To prevent shock, do not touch the nozzle or the stream-charging wire when the voltage warning light is illuminated or any time during sorting.

Sort Block

After leaving the nozzle, particles pass through the sort block where they are either transported to waste via the waste aspirator, or sorted into a collection device in the sort collection chamber. The sort block houses the high-voltage deflection plates, along with the aspirator and aspirator drawer (Figure 1-11).

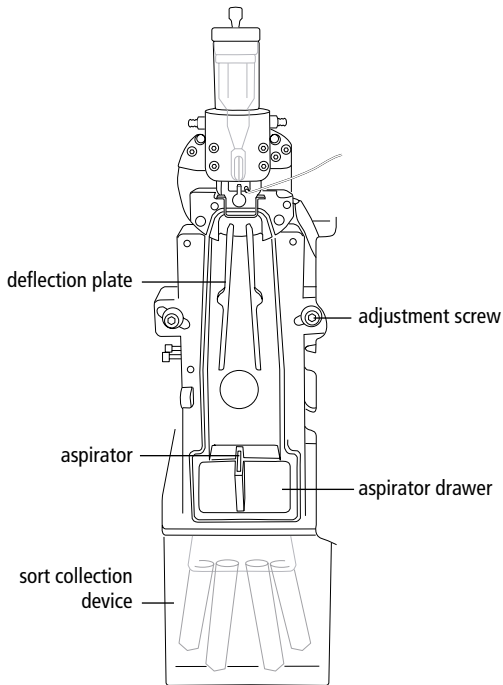

Figure 1-11 Sort block with door open

Note that the entire sort block assembly can be rotated on a fixed pivot point to adjust the position of the stream in the waste aspirator. If the keyed stream position differs between an old nozzle and a new one, the stream might not hit the center of the aspirator after the nozzle is changed. In this case, you can change the angle of the sort block by loosening the adjustment screws on either side of the deflection plates and rotating the sort block. Tighten the screws when the stream is re-centered in the aspirator.

Deflection Plates

The high-voltage deflection plates are used to deflect side streams during sorting. The plates are turned on and off using the Voltage control in the Side Stream window (see Side-Stream Formation on page 65). A red warning light is illuminated whenever the plate voltage is on (Figure 1-13 on page 34).

⚠ WARNING A 12,000-volt potential exists between the deflection plates when they are on. Contact with the charged plates results in serious electrical shock. Do not touch the deflection plates when the voltage warning light is illuminated, or when the software indicates that the plate voltage is on. The plates remain energized even when the sort block door is opened.

Aspirator Drawer

The aspirator drawer keeps the sort collection tubes covered until sorting begins (Figure 1-12). You can open and close the drawer using a control in the Sort Layout view (see Using Sorting Controls on page 94). The drawer closes automatically to protect your sort collection tubes when a clog is detected during sorting.

⚠ CAUTION To avoid pinching your hands or fingers in the drawer, keep your hands away from the sort block during sorting.

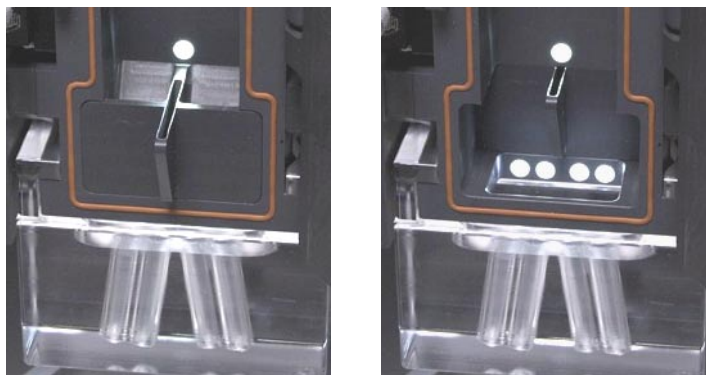

Figure 1-12 Aspirator drawer closed (left) vs open (right)

Aerosol Containment

During sample acquisition and sorting, the sort block door should be kept closed to help contain potential aerosols (Figure 1-13).

⚠ WARNING Cell sorters that use droplet generation methods, like the BD FACSAria, can produce aerosols around the sample stream. Inhalation or contact with aerosols exposes you to biologically transmissible diseases. When acquiring biohazardous samples, follow universal precautions at all times. Keep the sort block door closed during sorting. If you need to access the sort block, turn off the stream before opening the door.

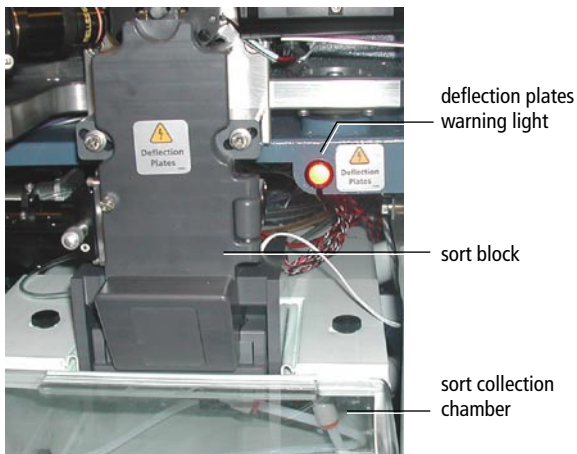

Figure 1-13 Sort block with door closed

Additional aerosol removal is provided by the BD™ Aerosol Management Option (AMO). The AMO is an optional device that evacuates the sort collection chamber during sorting. The AMO is equipped with a 0.01- μm pore ultra-low penetrating air (ULPA) filter to trap aerosolized particles. The AMO pump evacuates the sort collection chamber 16 times per minute in normal evacuation mode and 69 times per minute in rapid evacuation mode.

Sort Collection Chamber

Collection devices are installed in the sort collection chamber to collect sorted samples during sorting. The following collection devices are provided with the instrument to accommodate a variety of tube sizes:

- Four-way 1-mL collection tube holder
- Four-way 12 x 75-mm collection tube holder
- Two-way 12 x 75-mm collection tube holder
- Two-way 15-mL collection tube holder

An automated cell deposition unit (ACDU) that sorts into multiwell plates and onto microscope slides is available as an option. BD Biosciences also offers a temperature-control option to maintain the temperature of sorted samples during sorting.

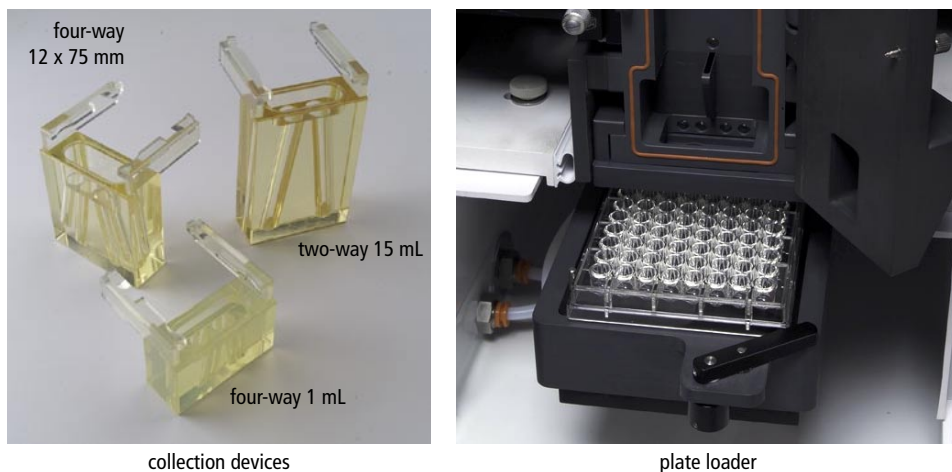

Figure 1-14 Sort collection devices

The sort collection chamber door should be kept closed when sorting into a plate. The door keeps the chamber free of dust and other air-borne particles, and seals the chamber during aerosol evacuation for instruments equipped with the AMO.

Optics System

The BD FACSAria cytometer uses innovative designs for both the excitation optics and collection optics. The optics can be viewed by opening the optics access door and the flow cell access door. See the following sections for more information.

⚠ NOTICE The flow cell access door is equipped with a shutter mechanism that shuts off the laser light when the door is opened. To prevent data loss, do not open the door during sample acquisition or sorting.

Excitation Optics

The excitation optics consist of lasers, fiber optic cables, beam-shaping prisms, and an acromatic focusing lens, as shown in Figure 1-15 on page 37. For information about how signals are generated, see Signal Generation on page 49.

The BD FACSAria instrument uses low-powered air-cooled and solid-state lasers that do not have special power and cooling requirements. The instrument comes standard with 488-nm and 633-nm lasers, and a third 407-nm laser is available as an option.

Lasers	Wavelength (nm)	Min. Power ^a (mW)	Commonly-Used Fluorochromes
Coherent Sapphire Solid State	488 (blue)	13	FITC, PE ^b , PE-Texas Red, PerCP, PerCP-Cy5.5, PE-Cy7, PI
JDS Uniphase HeNe Air Cooled	633 (red)	11	APC, APC-Cy7
Point Source Violet Solid State (optional)	407 (violet)	10	Alexa Fluor 430, Cascade Blue, DAPI, Hoechst

a. Measured out of fiber optic cable

b. Patents: PE and APC—US 4,520,110; 4,859,582; 5,055,556; Europe 76,695; Canada 1,179,942; PerCP—US 4,876,190; Cy—US 5,268,486; 5,486,616; 5,569,587; 5,569,766; 5,627,027; PE-Cy7—US 4,542,104; APC-Cy7—US 5,714,386

Fiber optics direct the laser light in a precise and constant manner onto beam-shaping prisms, which in turn transmit the laser light to a focusing lens. The lens

focuses the laser light onto the sample core stream within the cuvette flow cell (Figure 1-15). The lasers are positioned on the sample stream for optimal generation of signals. Since the optical pathway and sample core stream are fixed, optimization is constant from day to day.

⚠ WARNING Lasers emit intense, coherent electromagnetic radiation that can cause irreparable damage to human skin and eyes. To prevent retinal burns and possible blindness, do not remove laser shielding, adjust laser controls, or attempt to service the instrument any place where laser warning labels are attached. See Precaution Labels on page xvii for the placement of laser warning labels.

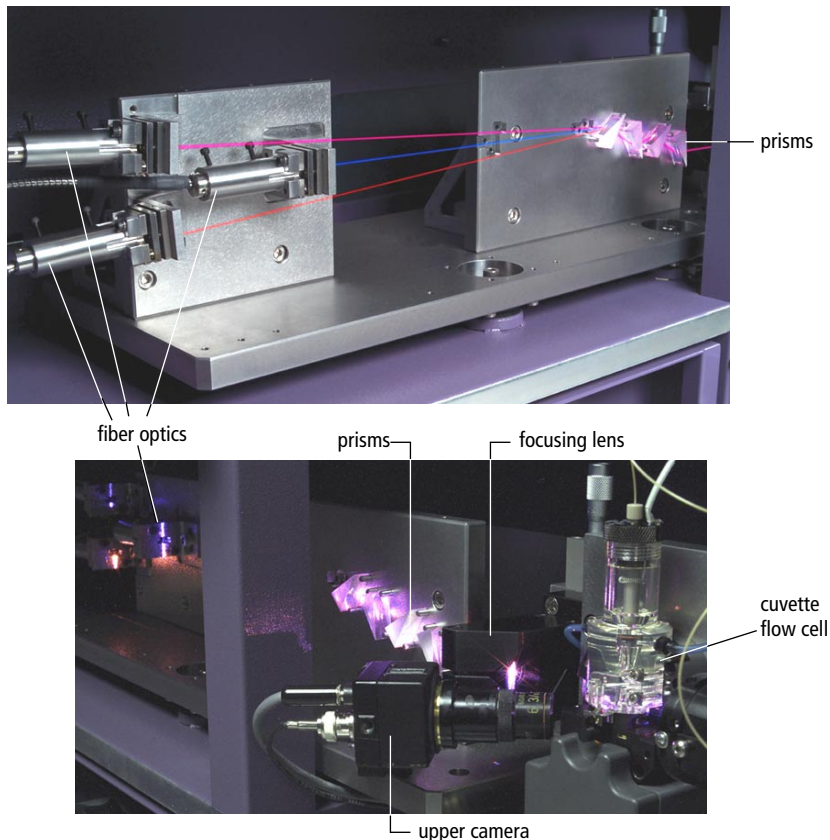
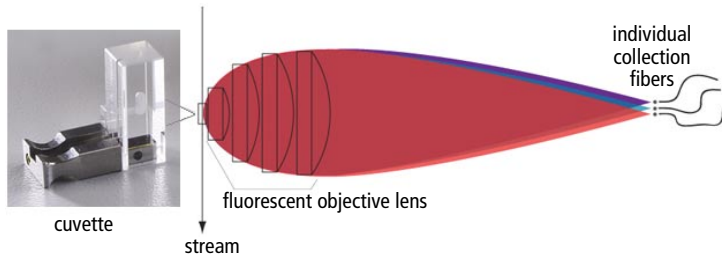

Figure 1-15 Excitation optics pathway (behind laser shielding)

Collection Optics

From the cuvette flow cell, laser light is collected by a fluorescent objective lens that is gel-coupled to the cuvette to transmit the maximum amount of light. The lens collects and focuses fluorescent light emitted at each of the laser focal points onto individual collection fibers. These fibers transfer the emitted light to the collection optics, as shown in the following figure.



The collection optics are set up in octagon- and trigon-shaped arrays that are engineered to maximize signal detection from each laser. This is accomplished by transmitting the highest wavelengths to the first photomultiplier tube (PMT), and reflecting lower wavelengths to the next PMT through a series of long-pass dichroic mirrors. Bandpass filters in front of each PMT allow fine-tuning of the spectral wavelengths that need to be collected. Since reflection is more efficient than transmittance, this design greatly increases the multicolor detection capabilities of the instrument.

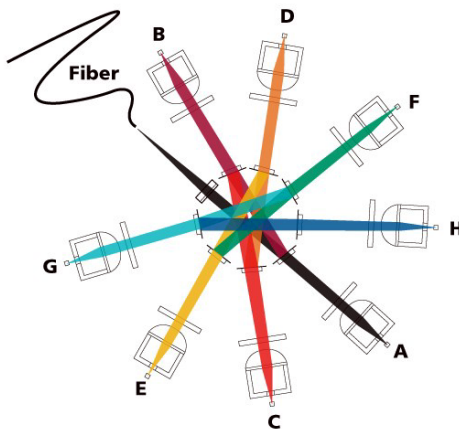

Detectors

A standard system is equipped with an octagon containing six PMTs, which detect light from the 488-nm (blue) laser, and a trigon containing two PMTs, which detect light from the 633-nm (red) laser. The third-laser option adds an additional trigon containing two PMTs to detect light from the 407-nm (violet) laser. Optical upgrades are available to fill the remaining PMT slots for a two- or three-laser system. A fully-equipped system can detect up to 13 fluorescent parameters and two scatter parameters at a time.

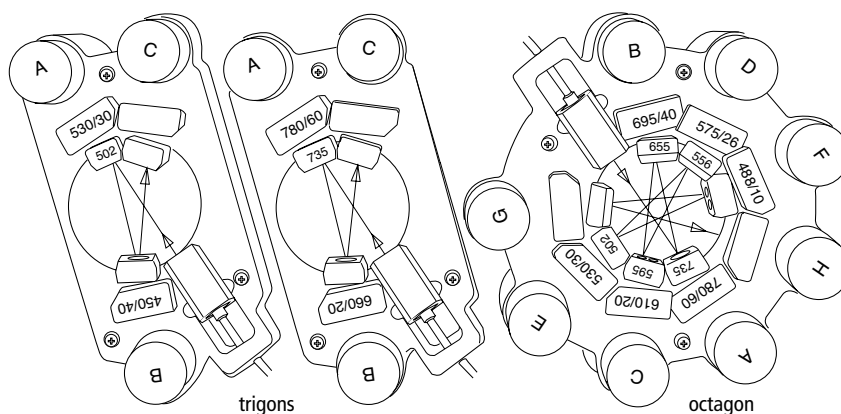

Figure 1-16 Fully-loaded detector arrays

At installation, the octagon and trigon arrays are set up with the filter and mirror combinations shown in Table 1-1. You can rearrange these configurations according to the type of fluorochromes in your experiment. See Application Options on page 232 for more information.

Table 1-1 Default setup for detector arrays

Detector Array (Laser)	PMT	LP Mirror	BP Filter	Intended Dye
Octagon (488-nm blue laser)	A	735	780/60	PE-Cy7
	B	655	695/40 675/20	PerCP-Cy5.5 or PI PerCP alone
	C	595	610/20	PE-Texas Red
	D	556	575/26 585/42	PE or PI Alternative for PE/PI when not using PE-Texas Red
	E	502	530/30	FITC
	F	—	488/10	Side scatter (SSC)
Trigon (633-nm red laser)	A	735	780/60	APC-Cy7
	B	—	660/20	APC
Trigon (407-nm violet laser)	A	502	530/30	Alexa Fluor 430, Hoeschst, DAPI
	B	—	450/40	Cascade blue, Pacific blue, Alexa Fluor 405

Stream-Viewing Optics

The BD FACSAria instrument is equipped with additional optical components that are used to view the stream (Figure 1-17 on page 41).

- The upper camera generates an image used to monitor drop formation. It is focused on the stream, just below the nozzle, to provide an image of the drop breakoff.
- The lower camera generates an image used for the BD™ AccuDrop function. It enhances the ability to see side streams and assists in setting an accurate drop delay value.

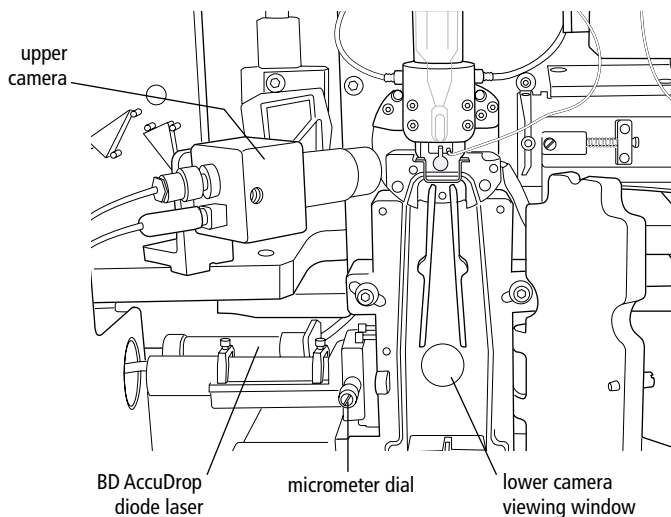

Figure 1-17 Stream-viewing optics

Special image-processing software allows you to view the stream images from each camera within separate windows in BD FACSDiVa software. See [Sorting](#) on page 60 for more information about viewing the streams and to learn how BD AccuDrop components are used to determine the drop delay.

Instrument Electronics

The electronic components consist of power controls and connectors along with processing boards in the card cage. This section describes only user-adjustable instrument electronics; for more information about the electronics, see [Signal Detection](#) on page 51.

Power Panel

Power to the instrument, lasers, and fluidics cart is supplied by a power cord plugged directly into a standard electrical outlet; there are no special facilities requirements. The main power switch turns on the instrument and fluidics cart, and enables the laser power switches. To turn on a laser, press the corresponding power button. The switch lights up when the power is on.

⚠ NOTICE Do not turn on the lasers until you have activated the stream. Running the lasers without activating the stream can degrade the performance of the cuvette flow cell.



Figure 1-18 Flow cytometer power panel

The instrument circuit breaker is located next to the power cord (Figure 1-18). The switch will need to be reset if there is a power surge in the laboratory.

Emergency Stop Button

The Emergency stop button to the right of the loading port (Figure 1-19) is a safety feature that can be used to halt the movement of the loading port and ACDU stage in case of need. The button lights up when a tube is loading to remind you to keep your hands away from the loading port.

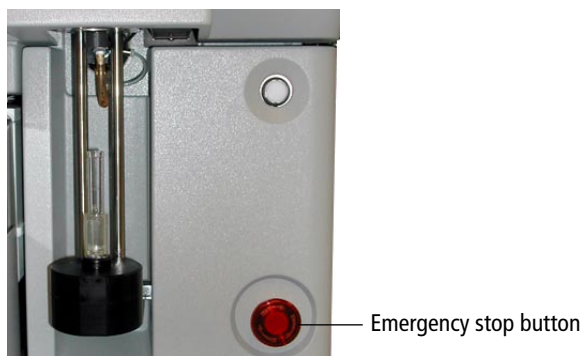

Figure 1-19 Emergency stop button

The following occur when this button is pushed:

- The tube is unloaded from the sample injection chamber.
- The ACDU stage (if in use) stops moving.
- The stream is turned off.
- The deflection plate voltage is turned off.
- The aspirator drawer (if open) closes to protect sort collection tubes.
- A warning message appears on the screen.

Do not reset the button until the message appears. To do so, turn the button clockwise until the light turns off and the button returns to its original position.

NOTICE The Emergency stop button does not turn off the lasers or shut down the instrument main power.

BD FACSAria Workstation

Data acquisition and analysis, as well as most BD FACSAria instrument functions, are controlled by BD FACSDiVa software on the BD FACSAria workstation. The workstation includes a desktop computer, one or two monitors, and a color printer, and is equipped with the following applications:

- Microsoft Windows 2000 operating system
- BD FACSDiVa software
 - Data acquisition and analysis
 - Automatic fluidics startup, shutdown, and cleaning modes
 - Sort setup, stream monitoring, clog detection, and recovery
- Supporting documentation for the software

For information about using BD FACSAria–specific software features, read Chapter 2, Theory of Operation, and Chapter 3, Using BD FACSDiVa Software. For more information about general software features, refer to the *BD FACSDiVa Software User's Guide*.

Tip Information about the software can be easily accessed by choosing User's Guide from the BD FACSDiVa Help menu.

Theory of Operation

I This chapter describes how the BD FACSAria instrument works and how BD FACSDiVa software components are used to operate different system components. For a general overview of the software, see Chapter 3.

See the following sections for a description of these BD FACSAria functions:

- Fluid Movement on page 46
- Signal Generation on page 49
- Signal Detection on page 51
- Electronic Processing on page 57
- Sorting on page 60

Fluid Movement

The fluidics system is responsible for moving particles from the sample injection chamber through the cuvette flow cell for interrogation, and then to waste or into a collection device during sorting (Figure 2-1). The following sections describe the controls used to move fluids through the BD FACSAria fluidics system.

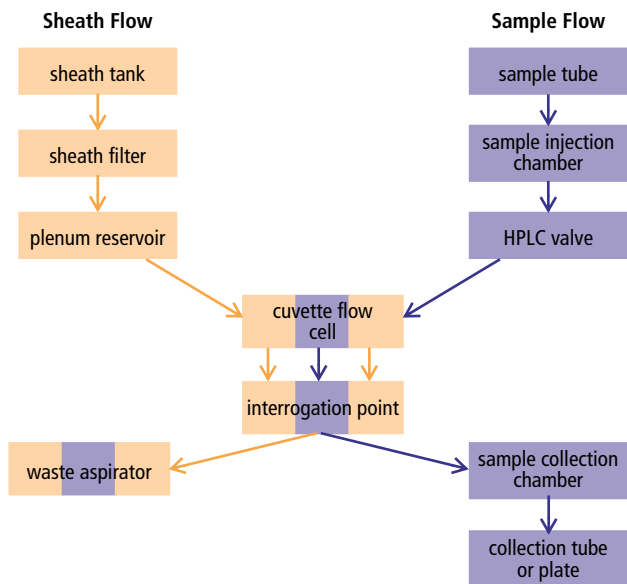

Figure 2-1 Fluidic movement via the fluidics system

Sheath Flow

When you turn on the instrument, the fluidic pumps start up. The fluidics system is activated when you choose the Fluidics Startup command in BD FACSDiVa software. During the fluidics startup procedure, sheath fluid is pumped from the sheath container through a 0.22- μ m filter into the plenum reservoir. The reservoir is pressurized to deliver sheath fluid to the cuvette flow cell at a constant pressure. You can view the current sheath pressure using the Instrument > Sheath Pressure command (Figure 2-2 on page 47).

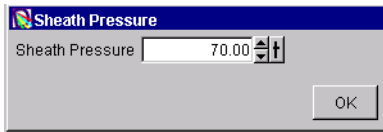

Figure 2-2 Sheath pressure level

After fluidics startup, sheath flow is controlled using the Stream button in the Breakoff window, which is labelled with the chosen sort pressure (Figure 2-3). When clicked, the button changes from a red “X” to a green checkmark, and sheath flows through the cuvette flow cell at the rate that is specified in the Sheath Pressure window. (See Drop Formation on page 61 for a complete description of the Breakoff window.)

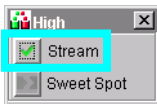

Figure 2-3 Stream control in Breakoff window

As a general rule, the sheath pressure level is set by choosing a Sort Setup option from the Sort menu, rather than by adjusting the Sheath Pressure control. Each Sort Setup option is optimized at a preset sheath pressure. If you change the sheath pressure, a multitude of other values will be affected, including the drop drive frequency, drop charge levels, laser delay, area scaling factor, and other values. For more information, see Sort Setup on page 89.

Sample Flow

Sample is introduced into the cuvette when the Load button is clicked in the Acquisition Controls frame (Figure 2-4 on page 48). After Load is clicked, the loading port rises to enclose the tube within the sample injection chamber. The chamber is automatically pressurized and the chamber pressure forces sample through the sample line into the cuvette flow cell. You can stop sample flow when a tube is loaded by clicking the Acquire button.

The sample flow rate is specified using the Flow Rate field in the Acquisition Controls frame. You can adjust the Flow Rate from 1–11, which corresponds to approximately 10–120 $\mu\text{L}/\text{min}$.

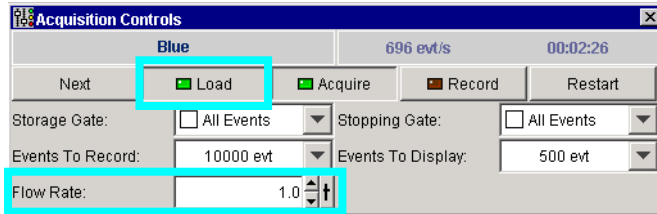

Figure 2-4 Load button and Flow Rate field in Acquisition Controls frame

Hydrodynamic Focusing

In the flow cell, pressurized sheath fluid surrounds the sample fluid to hydrodynamically focus the core stream of suspended cells into the center of the cuvette, where the particles are intercepted by the laser beam.

The difference in pressure between the sheath fluid and the sample fluid can be used to vary the diameter of the sample core. A lower difference results in a relatively narrow core stream, while a higher difference results in a wider sample stream (Figure 2-5).

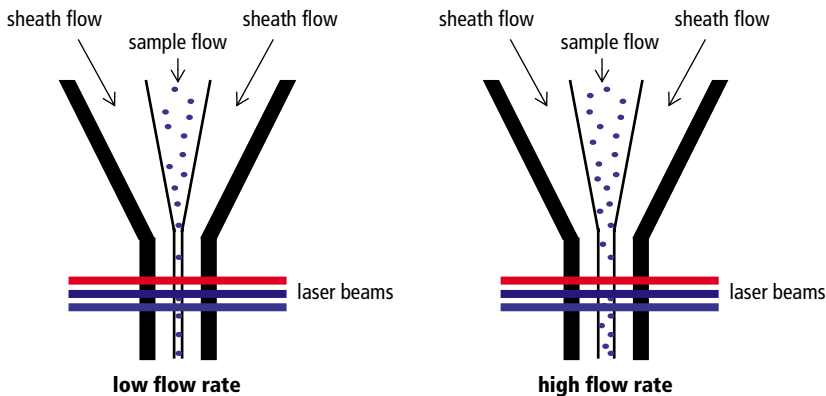

Figure 2-5 Hydrodynamic focusing of the sample core through the flow cell

Ideally, you want the core stream at its minimum diameter so that cells pass through the laser beam in a single-file stream. However, depending on your application, a lower resolution might be acceptable in order to acquire the data more quickly. For example, a higher flow rate is generally used for qualitative measurements such as immunophenotyping—the data is less resolved but is acquired more quickly. A lower flow rate is generally used in applications where greater resolution is critical, such as DNA analysis.

For sorting applications, sorting results are optimized at lower flow rates (<8.0).

Signal Generation

The following sections describe how signals are generated when cells or particles intercept the laser within the cuvette flow cell.

Light Scatter

When a cell or particle passes through a focused laser beam, laser light is scattered in all directions. Light that scatters axial to the laser beam is called forward scatter (FSC); light that scatters perpendicular to the laser beam is called side scatter (SSC). FSC and SSC are related to certain physical properties of cells:

- FSC—indicates relative differences in the size of the cells or particles
- SSC—indicates relative differences in the internal complexity or granularity of the cells or particles

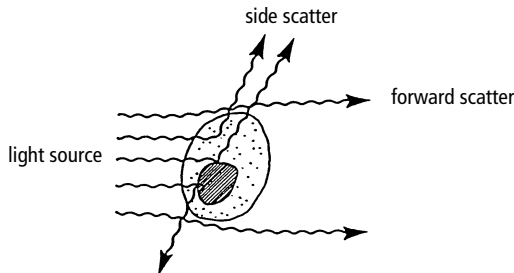

Fluorescent Signal

When cells or particles stained with fluorochrome-conjugated antibodies or other dyes pass through a laser beam, the dyes can absorb photons (energy) and be promoted to an excited electronic state. In returning to their ground state, the dyes release energy, most of which is emitted as light. This light emission is known as fluorescence.

Fluorescence is always a longer wavelength (lower-energy photon) than the excitation wavelength. The difference between the excitation wavelength and the emission wavelength is known as the Stokes shift. Some fluorescent compounds such as PerCP exhibit a large Stokes shift, absorbing blue light (488 nm) and emitting red light (675 nm), while other fluorochromes such as FITC have a smaller Stokes shift, absorbing blue light and emitting green light (530 nm).

The emission spectra for some commonly used fluorochromes are shown in Figure 2-6. See Table 1-1 on page 40 for the corresponding detectors.

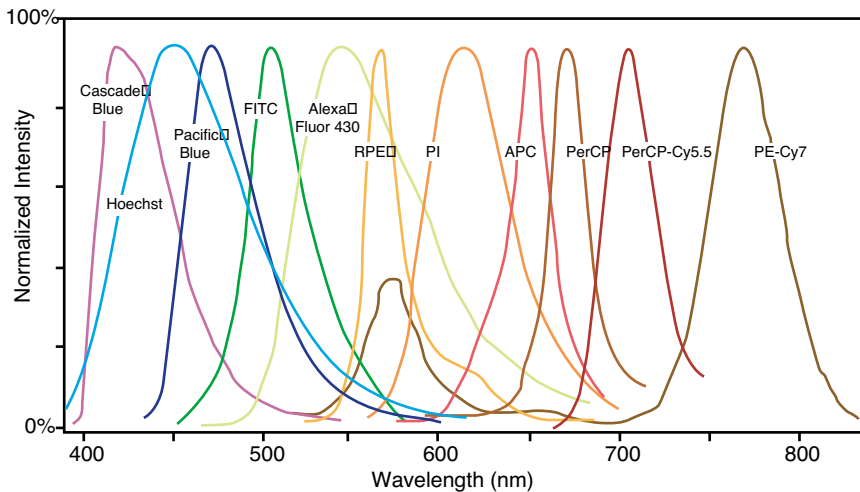

Figure 2-6 Emission spectra of commonly used fluorochromes

Signal Detection

From the cuvette flow cell, scattered and fluorescent light is collected by the fluorescent objective lens. The lens collects and focuses fluorescent light emitted at each of the laser focal points onto individual collection fibers. These fibers transfer the emitted light to the individual detector arrays.

This section describes how laser light is detected and translated into signals that can be displayed in a plot.

Detector Arrays

There are two types of detector arrays in the BD FACSAria flow cytometer: an octagon and trigons. The octagon detects SSC and up to seven fluorescent signals excited by the 488-nm (blue) laser. The trigons detect fluorescent signals excited by the 633-nm (red) and 407-nm (violet) lasers, respectively. Each trigon can detect up to three fluorescent channels. (An optical upgrade is required to fill all detection channels.)

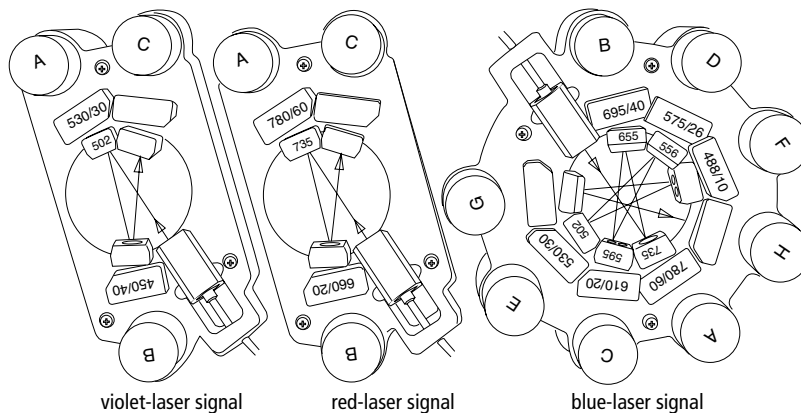

Figure 2-7 Octagon- and trigon-shaped detector arrays

Each detector array houses dichroic and bandpass filters, which steer and filter the emitted light, and photomultiplier tubes (PMTs), which detect light signals.

Filters

Optical filters modify the spectral distribution of light scatter and fluorescence directed to the detectors. Two kinds of filters are used in the detector arrays: longpass (LP) filters are used to steer light between the detectors within a detector array, while bandpass (BP) filters in front of each PMT allow fine-tuning the spectral wavelengths that need to be collected (Figure 2-8).

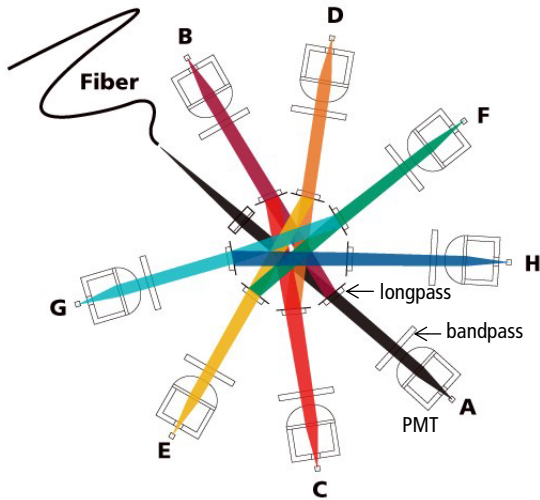

Figure 2-8 Detectors and filters in octagon array

Longpass Filters

Longpass (LP) filters pass wavelengths longer than the filter rating and reflect shorter wavelengths. For example, a 500 LP filter permits wavelengths longer than 500 nm to pass through it and reflects wavelengths shorter than 500 nm (Figure 2-9).

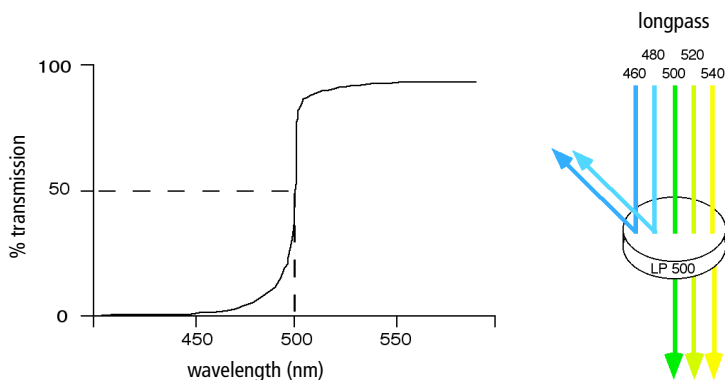

Figure 2-9 Light reflection by longpass filter

Dichroic filters that are used to direct different color light signals to different detectors are called dichroic mirrors or beam splitters.

Although dichroic mirrors have the properties of LP optical filters, you can not necessarily use any type of LP filter as a beam splitter. A beam splitter must have a surface coating that reflects certain wavelengths, but many types of LP filters are absorbance filters that do not have any specific reflective characteristics. Also, optical filters and beam splitters are rated at a specific angle of incidence. When used as a beam splitter, they are placed at an angle relative to the light source. Their optical properties are therefore designed for that angle of incidence.

The detector arrays use LP dichroic mirrors to steer progressively shorter wavelengths of light to the next PMT in the array. For example, in the octagon array, light first passes through a 735 LP filter in the A position, followed by a 655 LP filter in the B position. Thus, wavelengths longer than 735 nm are detected at PMT-A; all wavelengths <735 nm are reflected to PMT-B. Wavelengths between 655 nm and 735 nm are detected at PMT-B; all wavelengths <655 nm are reflected to PMT-C, and so on. For a list of the longpass filters used in the detector arrays, see Table 1-1 on page 40.

Bandpass Filters

Bandpass (BP) filters transmit a relatively narrow range or band of light. Bandpass filters are typically designated by two numbers. The first number indicates the center wavelength and the second refers to the width of the band of light that is passed. For example, a 500/50 BP filter transmits light that is centered at 500 nm and has a total bandwidth of 50 nm. Therefore, this filter transmits light between 475 and 525 nm (Figure 2-10).

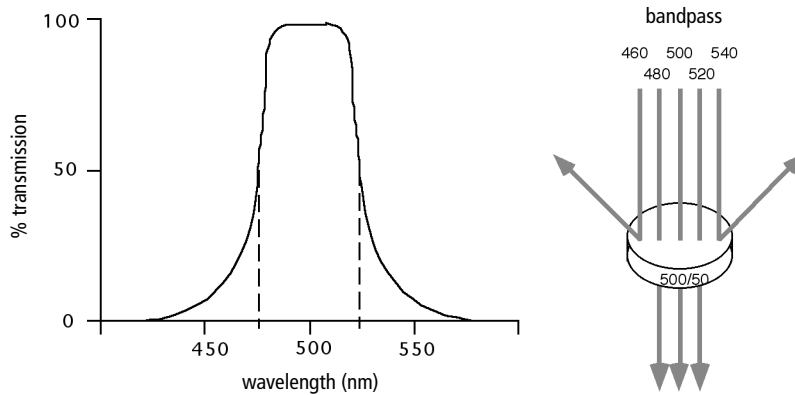

Figure 2-10 Light transmittance by bandpass filters

Discriminating (DF) filters have the same general function—they transmit a relatively narrow band of light. The principal difference between BP and DF filters is their construction. DF filters have more cavities or layers of optical coatings, resulting in a steeper transmission curve than the curve for a BP filter. This steep slope means that a DF filter is better at blocking light outside the rated bandwidth of the filter. See Figure 2-11 on page 55.

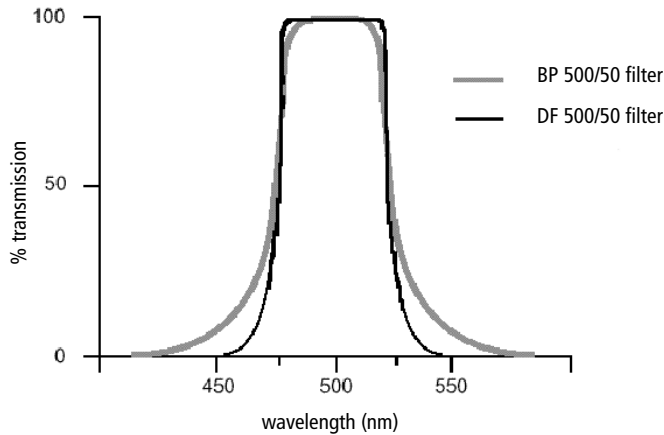

Figure 2-11 Bandpass (BP) vs discriminating (DF) filters

In the detector arrays, DF filters block high-intensity laser light and filter the remaining light to ensure that only the required wavelengths reach their intended detector. For example, in the octagon array, PMT-A has a 780/60 DF filter in front of it, which transmits light of 750–810 nm. Thus, the only wavelengths that will reach the A detector are those between 750 and 810 nm.

For optimal detection of fluorescent light, a bandpass filter must always be installed in front of each detector. For a list of the bandpass filters used in the detector arrays, see Table 1-1 on page 40.

Detectors

Detectors within each detector array convert light signals into electrical signals that can be processed by the electronics system.

There are two types of signal detectors in the BD FACSAria flow cytometer: the photodiode and photomultiplier tubes (PMTs). The photodiode is less sensitive to light signals than the PMTs, thus is used to detect the stronger FSC signal. The photodiode detects FSC light from the blue laser, and is stored outside the detector arrays. PMTs are used to detect the weaker signals generated by SSC and all fluorescence channels. The octagon can hold up to eight PMTs; each trigon can contain up to three PMTs.

Each PMT detects only one fluorochrome at a time. In BD FACSDiVa software, the Instrument Configuration dialog box lets you define which fluorochromes or cell parameters will be measured at each PMT detector. If more than one fluorochrome is measured using the same PMT, you can add additional parameters to your configuration and choose the appropriate fluorochrome within your software Experiment. See *Defining a New Configuration* on page 236 for more information.

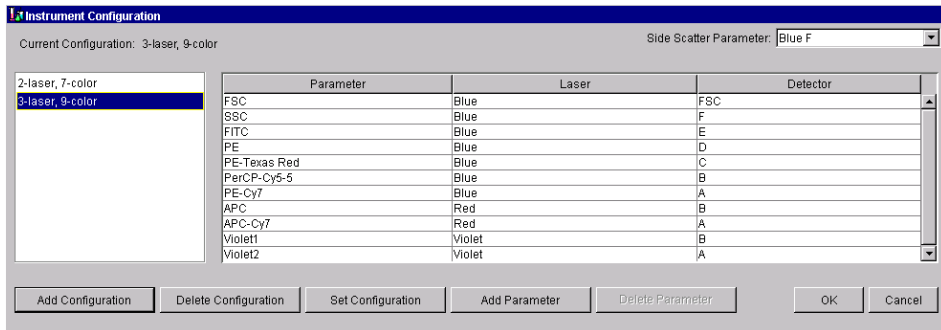

Figure 2-12 Default BD FACSAria instrument configurations

Electronic Processing

As cells or other particles pass through the focused laser beams, they scatter the laser light and can emit fluorescence. Because each laser beam is focused on a small spot and particles move rapidly through the flow cell, the scatter or fluorescence emission has a very brief duration—only a few microseconds. The PMTs convert this brief flash of light into an electrical signal called a pulse (Figure 2-13).

- 1** A pulse begins when a particle enters the laser beam. At this point, both the beam intensity and signal intensity are low.
- 2** The pulse reaches a maximum intensity or height when the particle reaches the middle of the beam, where the beam and signal intensity are the brightest. The peak intensity, or height of the pulse, is measured at this point.
- 3** As the particle leaves the beam, the pulse trails off.

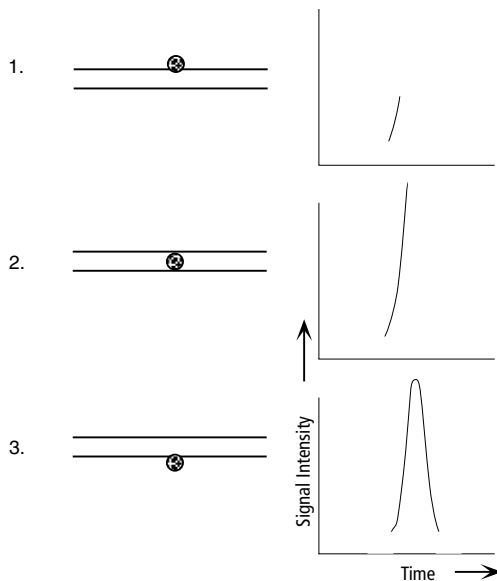
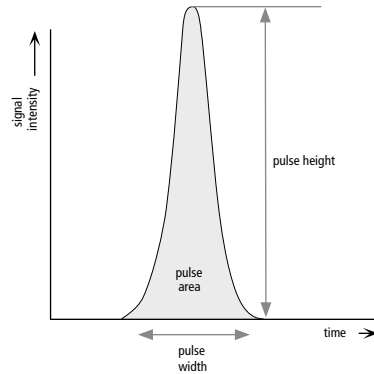

Figure 2-13 Anatomy of a pulse

Pulse Parameters

A *parameter* is a pulse property that is generated by a single photomultiplier tube or photodiode, measuring fluorescent or scattered light. You can measure three characteristics of a pulse: the area, height, or width. The pulse height measures the maximum digitized value for the pulse; the pulse area calculates the sum of all height areas for the pulse; and the pulse width calculates $\frac{\text{area}}{\text{height}} \times 64000$.



You can select which pulse characteristics you want to measure for each parameter using the Parameters tab of the Tube Inspector. Pulse area (A) is measured by default. The Parameters tab also contains Voltage controls that allow you to amplify signals by applying a voltage to PMTs or an electronic gain to FSC signal. As the voltage is increased, the detector sensitivity increases, resulting in increased signal. As the voltage is decreased, the detector sensitivity decreases, resulting in decreased signal.

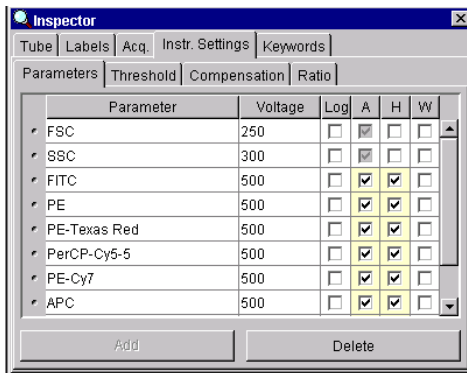

Digital data is displayed on an 18-bit linear scale, from 2.6–262,144. You can select the Log checkbox to convert the display to a log scale. The Experiment Inspector contains an option to display log data on a four- or five-decade scale. (Refer to the *BD FACSDiVa Software User's Guide* for more information.)

Laser Delay

Sample interrogation takes place within the cuvette flow cell. As described in Optics System on page 36, fiber optic cables are used to direct laser light through a series of prisms that focus each laser on the stream at a separate position. This allows optimal detection of fluorescent signal from each laser with minimal cross-contamination from the other beams.

In a three-laser system, the red laser intercepts the stream first, followed by the blue and then the violet laser. Because the laser signals are spatially separated, there is a slight delay between the detection of each laser's signal (Figure 2-14).

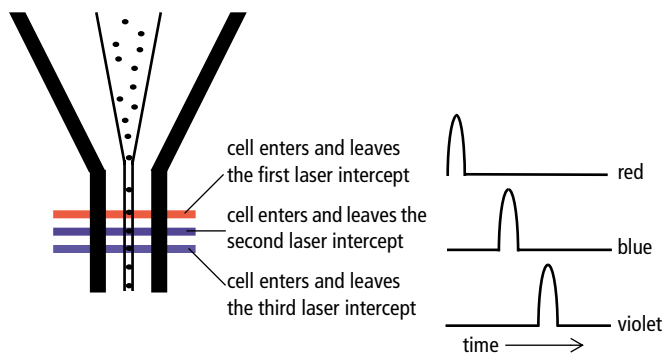

Figure 2-14 Signal separation over time

The Delay factor in BD FACSDiVa software is used to realign the signals so they can be measured and displayed on the same time scale. Note that signals are aligned with respect to the blue laser, so the red laser signals always have a negative Delay value (Figure 2-15 on page 60).

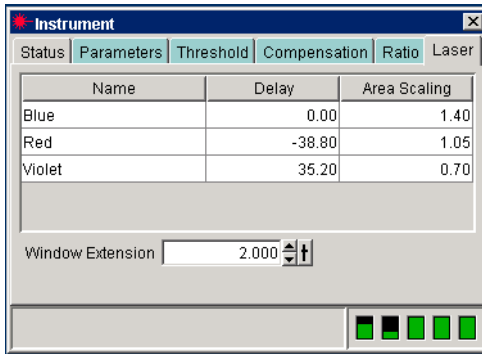

Figure 2-15 Delay values in Instrument frame

Sorting

During sorting, drop drive energy is applied to the stream to break it into highly uniform droplets. Droplets detach from the stream a few millimeters downstream from the nozzle. The time between when a particle intercepts the laser and when it reaches the droplet breakoff point is determined using BD AccuDrop technology (see Setting the Drop Delay on page 67).

When a particle is detected that meets the predefined sorting criteria, an electrical charge is applied to the stream just as the droplet containing that particle breaks off from the stream. Once broken off from the stream, the droplet—now surrounded by air—still retains its charge. The charged droplet passes by two strongly charged deflection plates. Electrostatic attraction and repulsion cause each charged droplet to be deflected to the left or right, depending on the droplet's charge polarity. Uncharged droplets are not affected by the electric field and pass down the center to the waste aspirator. See Figure 2-16 on page 61.

The following sections describe how the BD FACSAria instrument creates and charges drops, how the drops are deflected, and how sorting populations are identified.

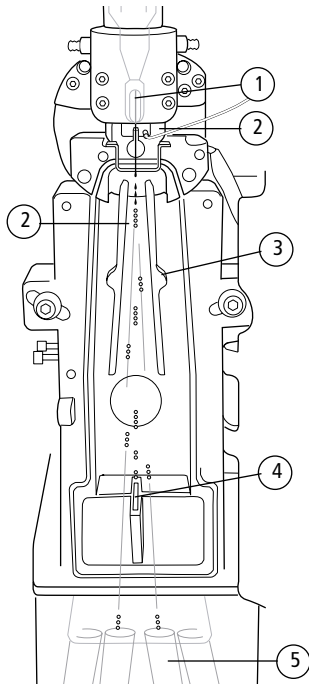

- ① Sample generates light scatter and fluorescent signal; signal is analyzed.
- ② Charge is applied via the stream-charging wire in the nozzle as the droplet breaks off.
- ③ Deflection plates attract or repel charged droplet.
- ④ Uncharged droplets pass to waste.
- ⑤ Charged drops containing particles of interest are collected.

Figure 2-16 Sorting

Drop Formation

The BD FACSAria instrument is unique in that drop drive energy is constantly applied to the stream; droplets form as soon as you turn on the stream. Sample interrogation takes place upstream of the stream vibration so that analysis is not affected by the drop drive.

A drop breakoff image is created using an LED strobe and a video camera. The image is displayed in the Breakoff window. (See Breakoff Window on page 62.) Patented Sweet Spot technology analyzes the drop breakoff image and provides feedback to the appropriate instrument controls.

Breakoff Window

The upper camera transmits an image of the drop breakoff to the Breakoff window, where video image processing software converts the visual characteristics of the image into numerical properties. The drop breakoff is analyzed for two key features: Drop 1 and Gap.

Drop 1 is defined as the number of pixels from the top of the image to the center of gravity of the first broken-off drop. A thin gray line on the image is used to identify this drop. The number shown to the right of the Drop 1 field at the bottom of the window is the actual pixel location of the gray line. The number entered into the Drop 1 field is the user-defined Drop 1 target.

The Gap is defined as the number of pixels from the first discontinuity in the stream to the next stream object, generally the first broken-off drop. A gray line of varying thickness represents the Gap. The number shown to the right of the Gap field is the pixel width of the gray line. The number entered into the Gap field is a user-defined target.

When the Sweet Spot is turned on, the drop drive amplitude (Ampl.) is automatically adjusted to approximately match the target Drop 1 and Gap values. The amplitude is initially adjusted in larger increments until Drop 1 is achieved. The amplitude is then adjusted in smaller increments until the instrument attains the target Gap. The Sweet Spot feature will make adjustments as necessary to maintain the required breakoff conditions throughout the day.



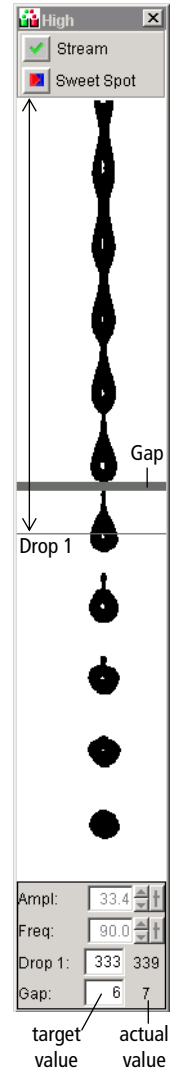

The Sweet Spot performs two other functions during sorting. When sorting, if the Drop 1 or Gap are out of range, sorting is paused until the values are back within range. This ensures that sorting occurs only under the proper breakoff conditions. If a more severe problem such as a clog is detected by the Sweet Spot, the stream is shut off and sorting is stopped: the deflection plates shut off, the aspirator drawer closes, and the sample tube is unloaded.



Preprogrammed values can be downloaded to the Breakoff window by choosing High, Medium, Low, or Custom from the Sort > Sort Setup menu.

Note that changes to values in the Sort Setup windows (Breakoff and Side Stream) are automatically saved. At startup, the last settings used on the instrument are restored, except the Stream and Sweet Spot controls which always default to off. Default values can be restored by choosing Sort > Sort Setup > Restore Defaults. For more information, see Sort Setup on page 89.

Table 2-1 Breakoff window controls

Control	Description
Stream button	Turns the stream on  and off  by clicking
Sweet Spot button	Enables automatic adjustment of the drop drive amplitude to maintain the stability of the breakoff point
 on	When the Sweet Spot is on, the Amplitude and Frequency fields are disabled; the amplitude is automatically adjusted by the software. To enable the fields, turn off the Sweet Spot.
 off	
Amplitude field	Adjusts the amplitude or intensity of the drop drive, from 1.0–80.0 volts
	The drop drive amplitude determines the breakoff point. A higher amplitude value results in a shorter stream breakoff; a lower amplitude results in a longer stream breakoff. Typically, the amplitude is set once, at the beginning of a sorting experiment, and then maintained via the Sweet Spot.
Frequency field	Determines the number of drops formed per second and the size of the drops (Drop size is also influenced by the nozzle size.)
	The drop drive frequency can be adjusted from 1.0–102.0 kHz. The higher the frequency, the more drops are generated per second and the smaller the drops. The lower the frequency, the less drops generated per second and the larger the drops.

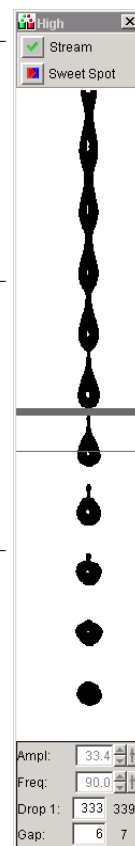

Table 2-1 Breakoff window controls (continued)

Control	Description
Frequency field (continued)	In general, the drop drive frequency should not need adjustment. BD Biosciences recommends using the default values that are input with each Sort Setup mode.
Drop 1 field	<p>The distance between the top of the image and the center of the first broken-off drop, from 100–600 pixels</p> <p>When you input a value and turn on the Sweet Spot, the instrument automatically adjusts the amplitude to attain your target value.</p> <p>Note that not all Drop 1 targets are attainable. The Drop 1 value jumps in whole increments of approximately 57 pixels according to your drop spacing.</p> <p>The same Drop 1 setting should be used from day to day; a difference of up to 10 pixels between the target value and the actual value is acceptable.</p>
Gap field	<p>Gap between the stream breakoff and the top of the first drop</p> <p>The default Gap setting is 6 pixels, and in general, it should never be adjusted. Differences of 1–2 pixels between the target value and the instrument-generated value are acceptable.</p>

Typically, when setting up for sorting, you use the Amplitude to set the required drop breakoff, and copy the generated Drop 1 value to the target field. Then, you turn on the Sweet Spot to maintain the drop breakoff. When the Sweet Spot detects a >1-pixel difference between the target Gap setting and the actual Gap, it adjusts the Amplitude to reduce the Gap. When a >2-pixel difference is detected, the Sweet Spot stops sorting temporarily (stops charging the stream) until the Gap is restored. Once the Gap is back within range, sorting automatically resumes.

- Tip** To save screen space, you can hide the fields at the bottom of the window after the amplitude has been set. To do so, right-click the window and choose Hide Controls from the contextual menu. (You can also choose to hide button labels.) To show the controls again, right-click the window and choose Show Controls.

For information on setting the breakoff, see Setting Up the Breakoff on page 141.

Side-Stream Formation

Side streams are formed when the voltage is on and you are sorting, or when you click Voltage, then Test Sort in the Side Stream window.

The Side Stream window displays an image of the side streams as transmitted by the lower camera. In addition to the stream image, the Side Stream window contains the controls used to adjust electrical charges and to determine the drop delay via BD AccuDrop, as described in Setting the Drop Delay on page 67.

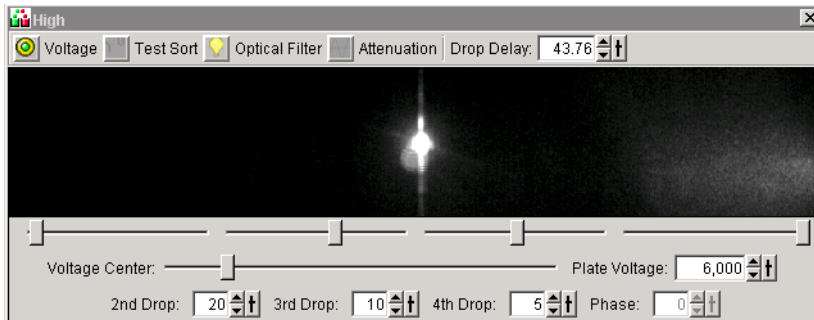









Figure 2-17 Side Stream window

Controls in the Side Stream window are described in Table 2-2 on page 66. Preprogrammed values can be downloaded to the Side Stream window by choosing High, Medium, Low, or Custom from the Sort > Sort Setup menu.

Note that changes to values in the Sort Setup windows (Side Stream and Breakoff) are automatically saved. At startup, the last settings used on the instrument are restored, except the states of the four button controls (Voltage, Test Sort, Optical Filter, and Attenuation) which always default to off. Default values can be restored by choosing Sort > Sort Setup > Restore Defaults. For more information, see Sort Setup on page 89.

- ✓ **Tip** To save screen space, you can hide the controls in the lower half of the window. To do so, right-click the window and choose Hide Controls from the contextual menu. (You can also choose to hide button labels.) To show the controls again, right-click the window and choose Show Controls.

Table 2-2 Side Stream window controls

Control	Description
Voltage button	Turns the plate voltage on  and off  by clicking
Test Sort button	Generates test side streams based on test sort pulses when the button is clicked
  on off	
Optical Filter button	Controls the position of the optical filter in front of the lower (BD AccuDrop) camera
  in out	
Attenuation button	Decreases the amplitude of the drop drive when the button is clicked. At startup, attenuation defaults to off. As a general rule, turn on attenuation when sorting below 30 psi.
  on off	
Drop Delay field	Sets the amount of time between when an event is measured and the breakoff point, from 10–140 drops. The drop delay value determines which drop will be deflected.
	The drop delay value is set experimentally using BD AccuDrop technology.
Voltage sliders (far left, left, right, far right)	Set the percentage of charge to be applied to the corresponding stream (as a percentage of maximum)
Voltage Center slider	Adjusts the relative voltage between the left and right plates which moves the streams slightly to the left or right as a whole
Plate Voltage field	Adjusts the total voltage difference between the plates, from 0–6000 volts
	The voltage difference determines the angle of stream deflection.
2nd, 3rd, 4th Drop fields	Apply a correction factor for the drop charge as a percentage of the previous drop, from –100 to 100%
Phase field	Adjusts the phase between drop generation and charging of the droplets from 0–360 degrees
	The selected value is sent to both the drop-charging electrode and the drop strobe. In general, the Phase never needs adjusting; you can keep the default value of zero.

Setting the Drop Delay

The BD FACSAria instrument includes integrated BD AccuDrop technology to assist in setting an accurate drop delay value. BD AccuDrop components consist of the following:

- a diode laser, mounted to the left of the sort block
- a second camera that provides an image of the side streams
- an emission filter for viewing the fluorescence from BD AccuDrop beads

The emission filter is installed in front of the lower camera and can be moved in and out by clicking the Optical Filter control. When the button is yellow () , the filter is out. This position is used to view the center and side streams.

Click the button to move the filter in front of the camera when you are determining the drop delay; the button changes to red (). To determine the drop delay, the streams are illuminated by the diode laser just below the point of deflection. Specialized fluorescent particles (BD AccuDrop beads) can be visualized in the center and left side streams as the delay is adjusted. The best delay yields the most particles in the left stream and the least in the center stream. See Determining the Drop Delay on page 145 for more information.

Particle Charging

Particles are charged when an event is detected that meets the defined sorting criteria, as determined by the Sort Layout window.

The Sort Layout is a floating window containing all sorting instructions and controls (Figure 2-18). The Sort Layout designates which device will be used to collect sorted particles and which particles will be sorted into each sort location. Up to four sort counters can be displayed in the window to give ongoing status during a sort. See Sort Layout on page 90 for more information about the Sort Layout window.

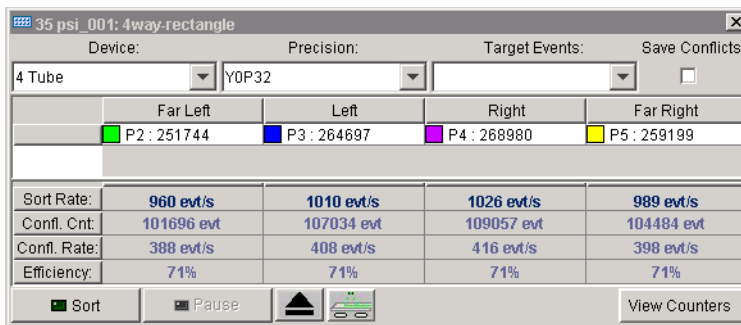
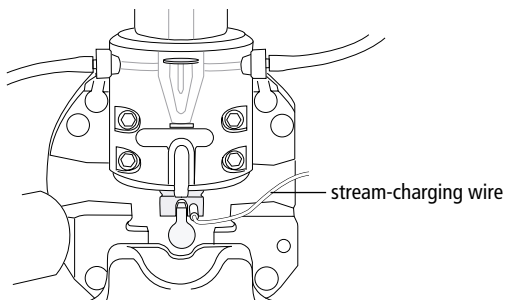

Figure 2-18 Sort Layout for four-way sort

Target events are identified by drawing gates around populations of interest in plots. The Sort Layout window specifies which gated population should be sorted into each sort collection tube or spot in a plate or on a slide. During sorting, when an event is identified within one of the sort gates, the drop containing the particle of interest is charged via the stream-charging wire.



The amount and type of charge determines where the drop will be sorted. For example, in a four-way sort, drops with the most charge will be deflected into the outer streams, while drops with less charge will be deflected into the inner streams.

Conflict Resolution During Sorting

During sorting, the cytometer deflects drops based on the characteristics of the particles in each drop and where the user wants to deflect them. Conflicts can occur depending on the type of target particle, where the particle is located within a drop, or whether the drop is free of contaminating particles.

BD FACSDiVa software accurately measures particle position to within 1/32 of a drop.

Mask settings determine how drops are deflected when sorting conflicts occur. There are three Mask settings, each of which addresses a different type of conflict. These settings are combined to define sort *Precision Modes*: each mode is made up of a set of masks. Precision Modes are defined in the Sort Precision dialog box, accessed from the Sort menu.

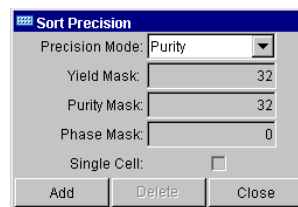

Yield Mask

The *Yield Mask* setting defines how close to the edge of the drop, in 1/32-drop increments, a particle of interest can be located before sorting an additional drop. Half of each Yield Mask setting defines an equal area at each end of the drop.

For example, when the Yield Mask is set to 16 and an event is within 8/32 from the beginning of a drop, the previous (leading) drop will be sorted. If an event is within 8/32 from the end of a drop, the following (trailing) drop will be sorted. See Figure 2-19 on page 70.

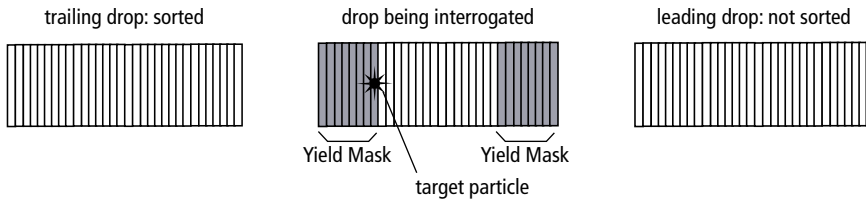

Figure 2-19 Target particle within a Yield Mask of 16

If the Yield Mask were set to 8 for the same target particle, the target particle would fall outside of the Yield Mask; thus no additional drops would be sorted. See Figure 2-20.

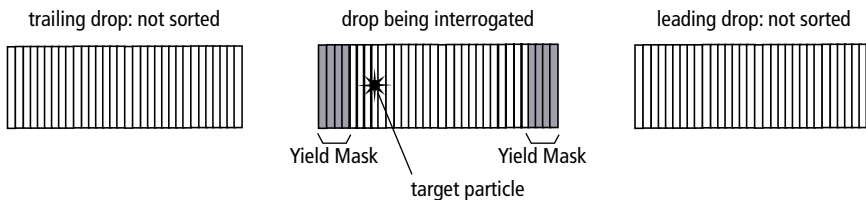

Figure 2-20 Target particle outside a Yield Mask of 8

When the Yield Mask is set to zero, only one drop (the drop containing the target particle) will be deflected; when the mask is set to 32, two drops will always be deflected. Yield Masks between 0–32 will sort either one or two drops.

NOTICE When more than one drop is deflected in the same direction, residual charge from the first drop degrades the quality of the side streams. Thus, when four-way sorting or sorting into small wells where precise deflection is required, a Yield Mask of zero is recommended.

Yield Masks cannot be used in conjunction with Phase Masks. Thus, when the Yield Mask is greater than zero, the Phase Mask automatically reverts to zero.

Purity Mask

The *Purity Mask* setting defines how close, in 1/32-drop increments, a contaminating drop can be located before ignoring the drop being interrogated.

For example, when the Purity Mask is set to 16, the drop being interrogated will not be sorted if a non-target particle falls within the first or last 8/32 of the leading or trailing drop. In the following example, a non-target particle falls within the first 8/32, so the interrogated drop will not be sorted (Figure 2-21).

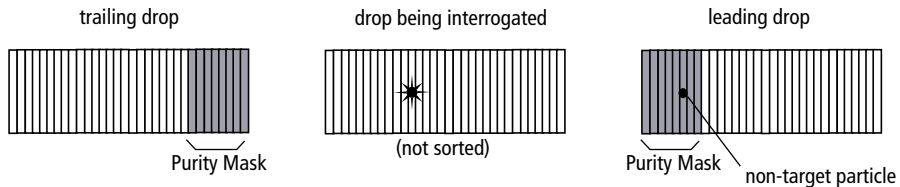

Figure 2-21 Non-target particle within a Purity Mask of 16

If the Purity Mask were set to 8 for the same target particle, the non-target particle would fall outside of the Purity Mask, so the interrogated drop would be sorted. See Figure 2-22.

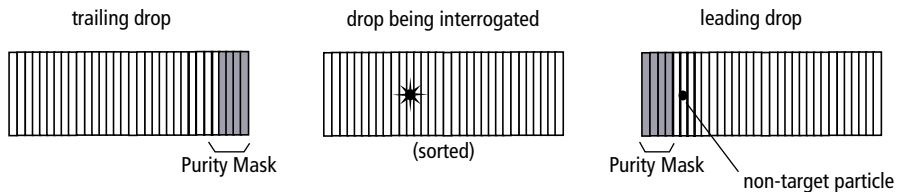

Figure 2-22 Non-target particle outside a Purity Mask of 8

NOTICE With any Purity mask greater than zero, the drop being interrogated must be free of contaminating particles or the drop will not be sorted.

Phase Mask

Particles near the drop edge can affect the breakoff and alter the trajectory of the deflected drop. The *Phase Mask* restricts drop deflection when an event is too close to the edge of a drop or when there are events close to the edge of adjacent drops. A Phase Mask is used to improve counting accuracy and side-stream quality at the expense of yield.

For example, when the Phase Mask is set to 16, the drop being interrogated will be sorted only if the target particle falls outside the Phase Mask (Figure 2-23).

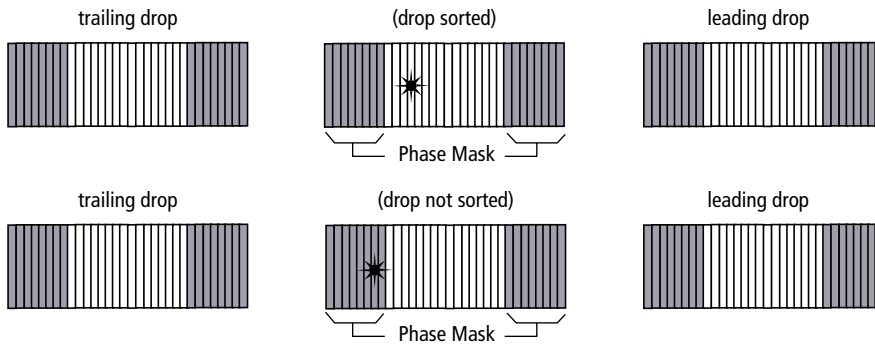

Figure 2-23 Sorted and unsorted drop with Phase Mask of 16

Decreasing the Phase Mask to 8 allows more drops to be sorted. However, because the target particle is closer to the edge of the drop, there is more variability in drop trajectory (Figure 2-24).

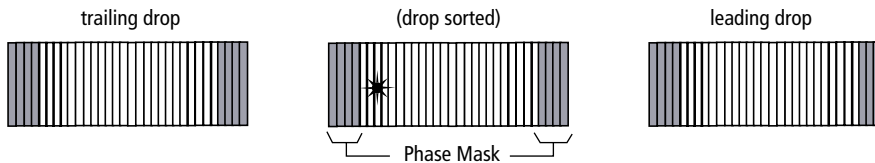

Figure 2-24 Sorted drop with Phase Mask of 8

Tip BD recommends using a Phase Mask of at least 8 when sorting single cells.

Phase Masks cannot be used in conjunction with Yield Masks. Thus, when the Phase Mask is greater than zero, the Yield Mask automatically reverts to zero.

Sort Precision Modes

Mask values can be combined in many different ways. By default, five Sort Precision modes are already defined—Purity, Yield, Single Cell, Initial, and Fine Tune.

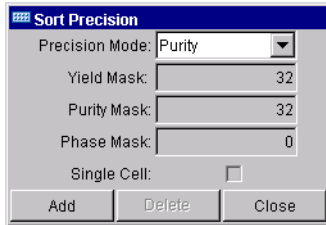

	Precision Mode				
	Purity	Yield	Single Cell	Initial	Fine Tune
Yield Mask:	32	32	0	32	0
Purity Mask:	32	0	32	0	0
Phase Mask:	0	0	16	0	0
Single Cell:	<input type="checkbox"/>	<input type="checkbox"/>	<input checked="" type="checkbox"/>	<input type="checkbox"/>	<input type="checkbox"/>

- In Purity mode, the Yield Mask is set to the maximum to obtain the greatest number of particles; because the Purity Mask is also at the maximum, only drops with a target particle will be sorted. Sorting in Purity mode results in a sorted sample that is highly pure, at the expense of recovery and yield.
- In Yield mode, only the Yield Mask is used at its maximum value; thus recovery and yield are optimized at the expense of purity.
- In Single Cell mode, the Purity Mask is set to the maximum, so only drops containing a target particle will be sorted. The Phase mask is set at half the maximum, so only particles centered within the sorted drop are deflected. Drop trajectory and count accuracy are optimized at the expense of yield.

This mode is recommended for single-cell sorting or situations where precise counting is required.

- Tip** Select the Single Cell checkbox to obtain the highest quality side streams and the most accurate counts. When the checkbox is selected, drops containing two target events (acceptable with a Purity Mask) are discarded. The Yield Mask is disabled when Single Cell is selected.

The remaining modes are used mainly during drop delay determination. Initial mode is equivalent to the Yield mode, but it is named differently as a reminder to use this as the initial mode when setting the drop delay using BD AccuDrop.

- In Initial mode, only the Yield Mask is used at its maximum value; thus recovery and yield are optimized at the expense of purity.
- In Fine Tune mode, all Masks are set to zero for deflecting the maximum number of drops. This mode is used to fine-tune the drop delay value. See Determining the Drop Delay on page 145 for more information.

Defining New Precision Modes

Default Precision modes cannot be edited; however, you can create new modes and then choose them from the Precision Mode drop-down menu.

- 1 Choose Sort > Sort Precision; click Add.

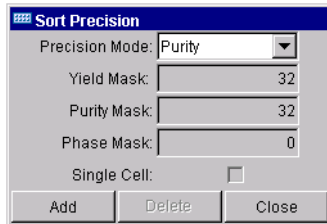

The current sort mode is duplicated and the Mask fields are enabled.

- 2 (Optional) Change the name of the mode in the Precision Mode field.
- 3 Enter values for the Yield, Purity, and Phase Masks.
- 4 Click to select the Single Cell checkbox, if needed.
- 5 Click Close.

The new mode is added to the Precision Mode drop-down menu.

To delete a mode, choose it from the drop-down menu and then click Delete.

3

Using BD FACSDiVa Software

All BD FACSAria instrument functions are controlled using BD FACSDiVa software. This chapter provides a general overview of the workspace components and describes instrument controls that are unique to the BD FACSAria instrument. For an in-depth description of software components not described in this chapter, refer to the *BD FACSDiVa Software User's Guide*.

The following topics are covered in this chapter:

- Workspace Components on page 78
- Instrument Controls on page 79
- Sorting Controls on page 87

Workspace Components

When you start BD FACSDiVa software, the workspace appears (Figure 3-1). *Frames* containing the main application components are displayed within the workspace by clicking the corresponding buttons in the Workspace toolbar (① in the figure). Frames shown in Figure 3-1 are numbered 2–7. Two additional frames can be displayed by clicking the Sorting button in the Workspace toolbar; see *Sorting Controls* on page 87 for a description.

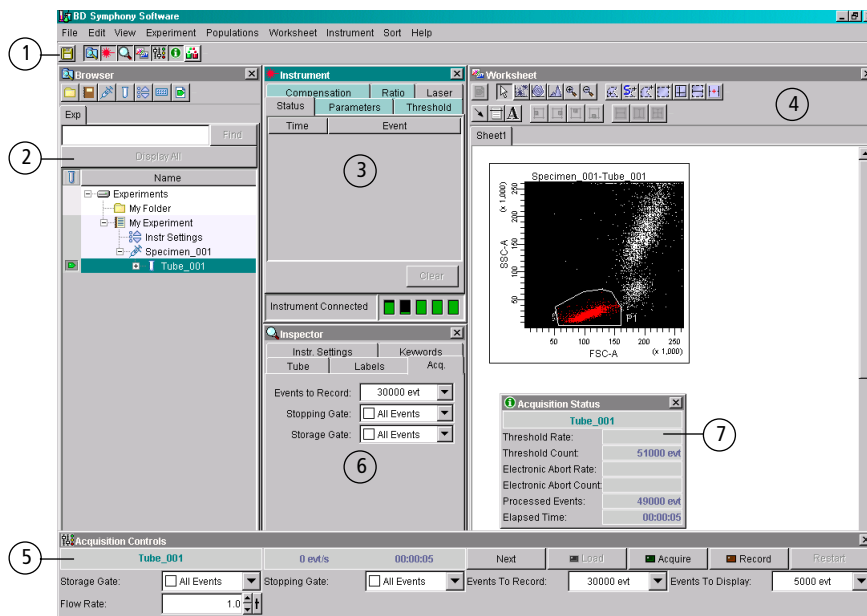

Figure 3-1 BD FACSDiVa workspace

①	Click a button in the Workspace toolbar to hide or show the corresponding frame. Frames can be resized by dragging a border or corner.
②	The Browser frame lists all experimental data in a hierarchical view, provides an interface for setting up Experiments, and contains an Acquisition pointer control for acquiring and recording data.

③	When connected to an instrument, the Instrument frame shows instrument connectivity status, fluidics level indicators (sheath, waste, bleach, deionized water, ethanol), status messages, instrument settings for the current acquisition Tube, and Laser controls.
④	The Worksheet frame provides an area where you can create Acquisition Templates or worksheets containing plots, gates, statistics, and custom text.
⑤	The Acquisition Controls frame contains controls used to acquire and record data. Along with the general controls described in the <i>BD FACSDiVa Software User's Guide</i> , the Acquisition Controls frame displays additional fluidics controls for the BD FACSAria instrument. See Acquisition Controls on page 86 for a description.
⑥	The Inspector frame provides an easy-to-use interface for viewing or modifying the attributes of a single object or set of objects on the worksheet or in the Browser.
⑦	The Acquisition Status frame provides ongoing status during acquisition or recording.

Instrument Controls

Most BD FACSAria-specific instrument controls are accessed through the Instrument menu. Instrument controls on the Instrument menu are described in the following sections:

- Fluidics Controls on page 80
- Instrument Configuration on page 84
- Instrument Status Report on page 85

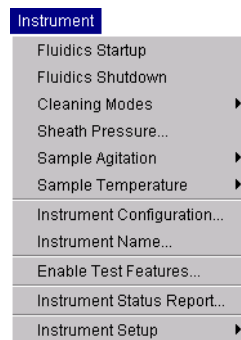

The Enable Test Features command is password-protected. It is used by BD Biosciences service engineers to diagnose and adjust certain instrument settings. Other menu commands (Instrument Name, Instrument Setup) are described in the *BD FACSDiVa Software User's Guide*. Additional instrument controls are located in the Acquisition Controls frame; see Acquisition Controls on page 86.

Fluidics Controls

Fluidics control of the BD FACSAria instrument is completely automated by BD FACSDiVa software. The software contains pre-programmed fluidics protocols that are activated by choosing the corresponding menu command from the Instrument menu. In addition, fluidics level indicators are available in the Instrument frame; see Fluidics Level Indicators on page 83.

Fluidics Startup

The Fluidics Startup procedure verifies waste and sheath levels and primes the fluidics system with sheath solution. See Starting Up the Instrument on page 100 for more information.

Fluidics Shutdown

The Fluidics Shutdown procedure removes sheath from the lines and plenum and replaces it with DI water, and cleans the cuvette with a cleaning solution. See Fluidics Shutdown on page 172 for more details.

Cleaning Modes

BD FACSDiVa software contains pre-programmed cleaning modes that are activated by choosing the corresponding menu command from the Instrument > Cleaning Modes menu. See Internal Cleaning on page 178 for more information.

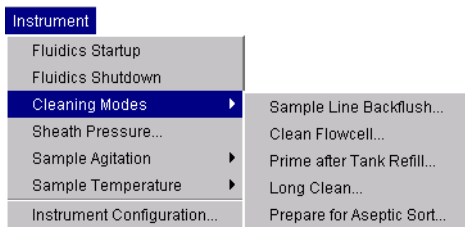

Sheath Pressure

The sheath pressure determines how quickly particles pass through the laser beam. Choose Instrument > Sheath Pressure to access a dialog box where you can view the current sheath pressure.

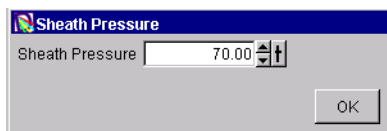

⚠ NOTICE Each Sort Setup option is optimized at a preset sheath pressure. If you change the sheath pressure, a multitude of other values will be affected, including the drop drive frequency, drop charge levels, laser delay, area scaling factor, and other values. For proper instrument operation, change the sheath pressure by choosing an option from the Sort > Sort Setup menu; do not adjust the pressure using controls in the Sheath Pressure dialog box. Note that the Sheath Pressure command is disabled when the Sweet Spot is on.

Sample Agitation

Choose Instrument > Sample Agitation to specify the speed at which samples are agitated. You can choose from one of the specified values, or choose Off to turn off agitation.

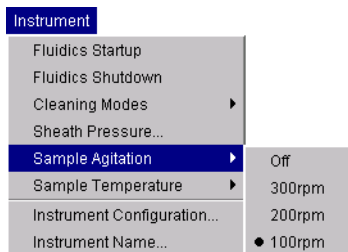

Sample Temperature

Use the Sample Temperature command to set the temperature inside the sample injection chamber. You can choose from one of the specified values, or choose Off to turn off temperature control (Figure 3-2 on page 82).

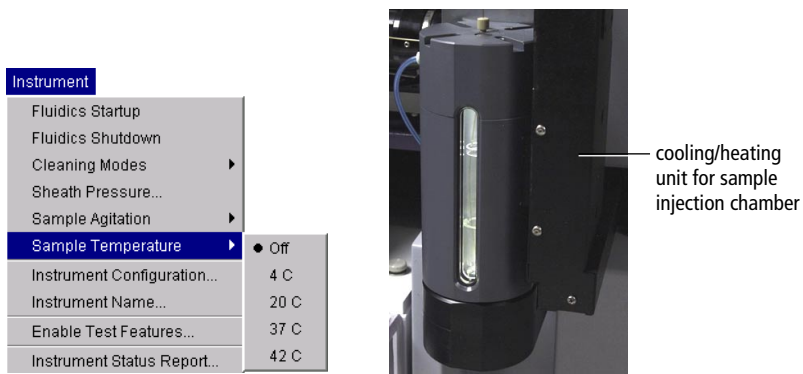

Figure 3-2 Setting the sample temperature

NOTICE The cooling/heating unit is designed to maintain the temperature of a sample tube; it is not designed to cool or heat the sample. Note that it takes approximately 45 minutes to reach the required temperature inside the chamber, during which time the chamber must be kept closed.

To cool or heat the chamber, install a sample tube and click Load, and then click Acquire to keep the chamber closed and stop running the sample. To maintain the temperature, do not leave the chamber open for extended periods when changing sample tubes.

Fluidics Level Indicators

BD FACSDiVa software provides fluidics level indicators in the Instrument frame (Figure 3-3). The sheath and waste indicators provide an approximate indication of the fluid levels in each tank. The DI, bleach, and ethanol tank indicators appear full until the fluid level descends below 20% of the tank capacity. When this occurs, the corresponding level indicator changes to black.

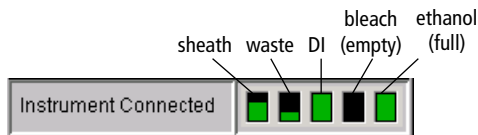
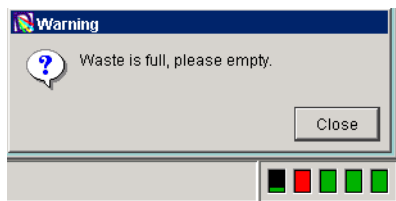

Figure 3-3 Levels indicators

When the sheath is low or the waste is full while the stream is running, the corresponding indicator turns red and the following warning message is displayed every 5 minutes until the stream is turned off. If the warning message is not dismissed, the system automatically turns off the stream after 15 minutes.



⚠ NOTICE Do not dismiss the warning message without refilling the sheath or emptying the waste. If you continue to run the instrument after dismissing the message, the waste container could overflow or the sheath container could run dry.

For a description of other controls in the Instrument frame, refer to the *BD FACSDiVa Software User's Guide*. Delay information specific to the BD FACSAria instrument is described in Laser Delay on page 59.

Instrument Configuration

The BD FACSAria instrument is equipped with a specific set of lasers, filters, and dichroic mirrors. The Instrument Configuration dialog box lets you define which fluorochromes or cell parameters will be measured at each photomultiplier tube (PMT) detector. Within this dialog box, you can define parameters for an unlimited number of fluorochromes, up to three lasers, and up to 15 detectors.

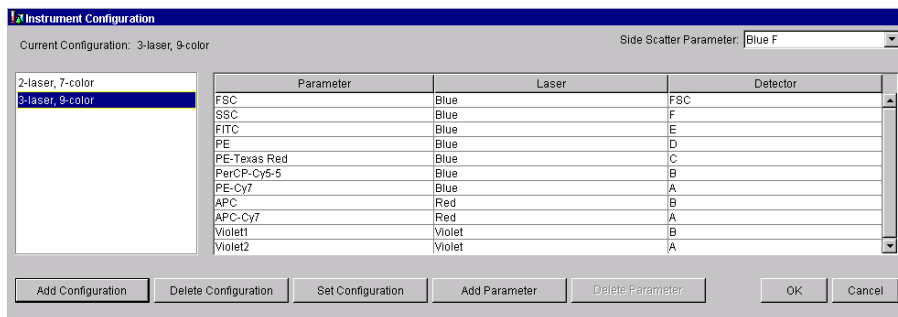

For the BD FACSAria instrument, default configurations are provided for two- and three-laser systems. You can switch between the default configurations depending on your system setup and application. Examples of instrument configurations for common applications can be found in Application Options on page 232. In addition, you can define custom configurations, or add or modify the labels in an existing configuration. See Defining a New Configuration on page 236 for instructions.

Selections made in the Instrument Configuration dialog box will determine which parameters are listed on the Parameters tab in the Inspector or the Instrument frame. If you use one PMT detector to measure multiple fluorochromes, you can list all possible fluorochromes in the Instrument Configuration dialog box and choose the appropriate fluorochrome in the Parameters tab.

⚠ NOTICE For accurate data results, the instrument optics setup must match the current Instrument Configuration.

Instrument Status Report

Choose Instrument > Instrument Status Report to view a report of the current instrument settings. The Instrument Status Report is displayed in a separate window with a menu bar above the report header.

For a full description of the Instrument Status Report, refer to the *BD FACSDiVa Software User's Guide*. A BD FACSAria instrument report includes the following additional information.

- The Instrument Info section lists the sheath pressure and flow rate, along with the lasers used, corresponding Laser Delay and Area Scaling factors, and the Window Extension.
- The Sort Settings section lists all sort setup values, along with the Plate Voltage and Voltage Center values. If the Sweet Spot is off, Breakoff and Gap values are shown; if the Sweet Spot is on, Drop 1 and target Gap values are shown.

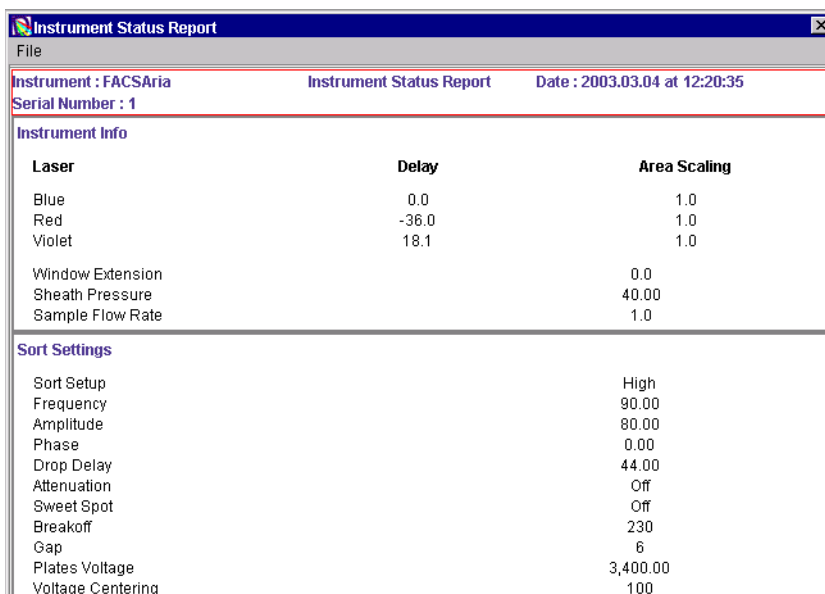

The screenshot shows a window titled "Instrument Status Report" with a menu bar containing "File". Below the menu bar, the report header displays "Instrument : FACSAria", "Instrument Status Report", and "Date : 2003.03.04 at 12:20:35". The "Serial Number : 1" is also shown. The report is divided into two main sections: "Instrument Info" and "Sort Settings".

Instrument Info		
Laser	Delay	Area Scaling
Blue	0.0	1.0
Red	-36.0	1.0
Violet	18.1	1.0
Window Extension		0.0
Sheath Pressure		40.00
Sample Flow Rate		1.0

Sort Settings	
Sort Setup	High
Frequency	90.00
Amplitude	80.00
Phase	0.00
Drop Delay	44.00
Attenuation	Off
Sweet Spot	Off
Breakoff	230
Gap	6
Plates Voltage	3,400.00
Voltage Centering	100

Acquisition Controls

Along with the controls described in the *BD FACSDiVa Software User's Guide*, the following acquisition controls are available for the BD FACSAria instrument.



- **Load**—lifts a tube into the sample injection chamber, starts sample agitation (if agitation is turned on), and starts acquisition of the sample

When a tube is already loaded, the button changes to Unload. Clicking Unload stops acquisition of the sample, turns off the agitator, and lowers the tube from the sample injection chamber.

NOTICE The Load button is enabled only when the workstation is connected to the instrument, an Experiment is open, and the stream is turned on.

- **Flow Rate**—controls the sample flow rate, from 1.0–11.0

Do one of the following to change the flow rate:

- Select the value in the field and enter a new value.
- Click the pointer in the slider bar and drag it to a new value.
- Use the mouse to click the up and down arrows or press the arrow keys on your keyboard to increase or decrease the values in small increments.

Sorting Controls

All sorting on the BD FACSDiVa instrument is controlled by BD FACSDiVa software. Sorting controls are shown in Figure 3-4.

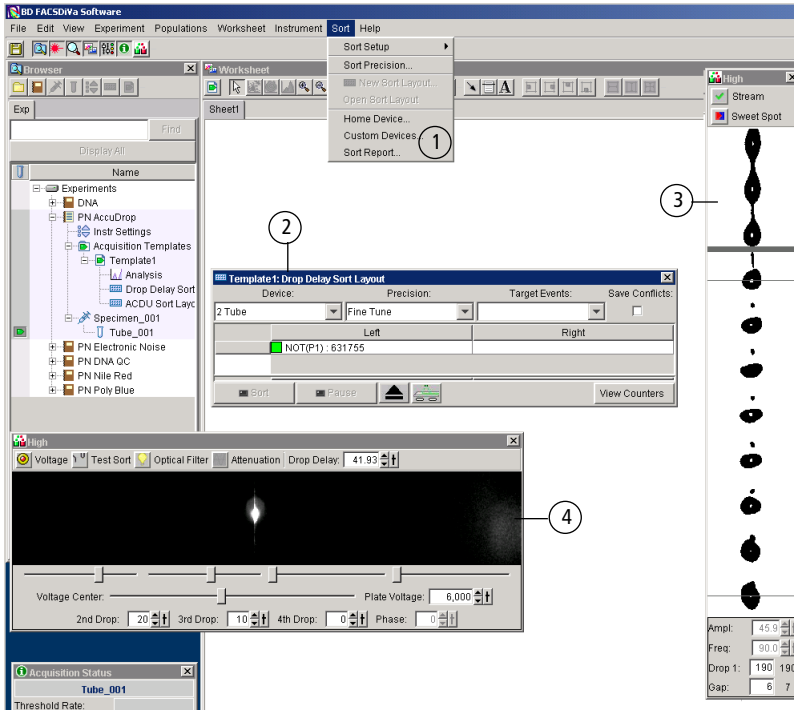

Figure 3-4 BD FACSDiVa sorting controls

<p>①</p>	<p>The Sort menu provides access to Sort Setup and Sort Precision modes, Sort Layouts, Sort Reports, and sort devices used with the automated cell deposition unit (ACDU). See Sort Menu on page 88.</p>
<p>②</p>	<p>The Sort Layout window designates which device will be used to collect sorted particles and which particles will be sorted into each sort location. Sorting controls and counters are also displayed in the window. See Sort Layout on page 90.</p>

③	The Breakoff window displays an image of the stream and contains controls to adjust drop formation. See Drop Formation on page 61.
④	The Side Stream window displays an image of the side streams, and contains controls to adjust electrical charges and the drop delay. See Side-Stream Formation on page 65.

Sort Menu

Choose commands in the Sort menu for the following.

- Sort Setup—downloads the most recently used settings for high-, medium-, or low-pressure sorting; see Sort Setup on page 89.
- Sort Precision—opens a dialog box where you can choose or define a Sort Precision mode for handling sorting conflicts; see Conflict Resolution During Sorting on page 69.
- New Sort Layout—opens the default 2-Tube Sort Layout view where other Sort Layouts can be chosen; see Sort Layout on page 90. (Note that clicking the Sort Layout button on the Browser toolbar performs the same function.)
- Open Sort Layout—opens an existing Sort Layout. A Sort Layout must be selected in the Browser for this menu command to be enabled. Alternatively, double-click any Sort Layout to open it.
- Home Device—opens a dialog box containing commands to move the tray support arm, either manually or to the home position; see Setting Up the Stream on page 155.
- Custom Devices—opens a dialog box where custom devices can be defined; see Creating a Custom Device on page 158.
- Sort Report—displays a report showing the sort settings, acquisition counters, and Sort Layout information from the current sort. See Sort Report on page 97.

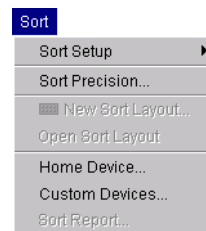

Sort Setup

Sort setup values for high-, medium-, and low-pressure sorting can be downloaded using the Sort > Sort Setup command. Default settings are provided for each sorting option, along with Custom settings for non-sorting applications. Use the following guidelines to determine which Sort Setup option to use.

Sort Setup	Nozzle (μm)	Recommended Applications
High	70	High-speed, high-throughput sorting
Medium	70	Sorting of cell lines, fragile cells
Low	100	Single-cell sorting, ACDU sorting, sorting of large or fragile cells
Custom	70	Non-sorting mode for high sensitivity

If you make changes to any of the settings, changes are automatically saved when you quit BD FACSDiVa software or when you switch to a different Sort Setup mode. When you restart, the most recently used set of values is restored. You can restore the High, Medium, or Low default settings by choosing Sort > Sort Setup > Restore Defaults. Default settings are shown in Table 3-1.

Table 3-1 Default Sort Setup values

Setting	High	Medium	Low	Custom
Sheath Pressure	70	35	20	20
Amplitude	60	50	20	10
Frequency	90	60	30	30
Drop 1	330	330	330	330
Gap	6	6	6	6
Attenuation	off	on	on	off
Drop Delay	44.00	45.00	29.00	10.00

Table 3-1 Default Sort Setup values (continued)

Setting	High	Medium	Low	Custom
Far left voltage	90	45	45	0
Left voltage	40	20	20	0
Right voltage	40	20	20	0
Far right voltage	90	45	45	0
Plate voltage	6,000	5,000	5,000	0
2nd Drop	20	20	10	0
3rd Drop	10	10	5	0
4th Drop	0	0	0	0
Laser Delay (blue)	0.00	0.00	0.00	0.00
Laser Delay (red)	-36.00	-54.00	-40.00	-82.00
Laser Delay (violet)	36.00	54.00	40.00	82.00
Area Scaling (blue)	1.40	1.20	1.40	0.75
Area Scaling (red)	1.00	0.75	1.00	0.50
Area Scaling (violet)	0.80	0.35	0.50	0.25
Window Extension	2.00	2.00	2.00	4.00

Sort Layout

A Sort Layout is a floating window containing all sorting instructions and controls. The Sort Layout designates which device will be used to collect sorted particles and which particles will be sorted into each sort location. Up to four sort counters can be displayed in the window to give ongoing status during a sort.

Only one Sort Layout can be open at a time, but you can create several layouts for a single Tube, as long as each Sort Layout has a different name. Sort Layouts can also be added to Acquisition Templates.

Sort Layouts are available for up to nine default collection devices; additional custom devices can be defined. (See Creating a Custom Device on page 158.)

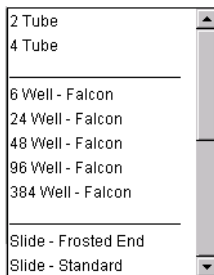

default collection devices

Examples of Sort Layouts for different devices are shown in the following figures; instructions for setting up the Sort Layout can be found in Setting Up a Sort Layout on page 92.

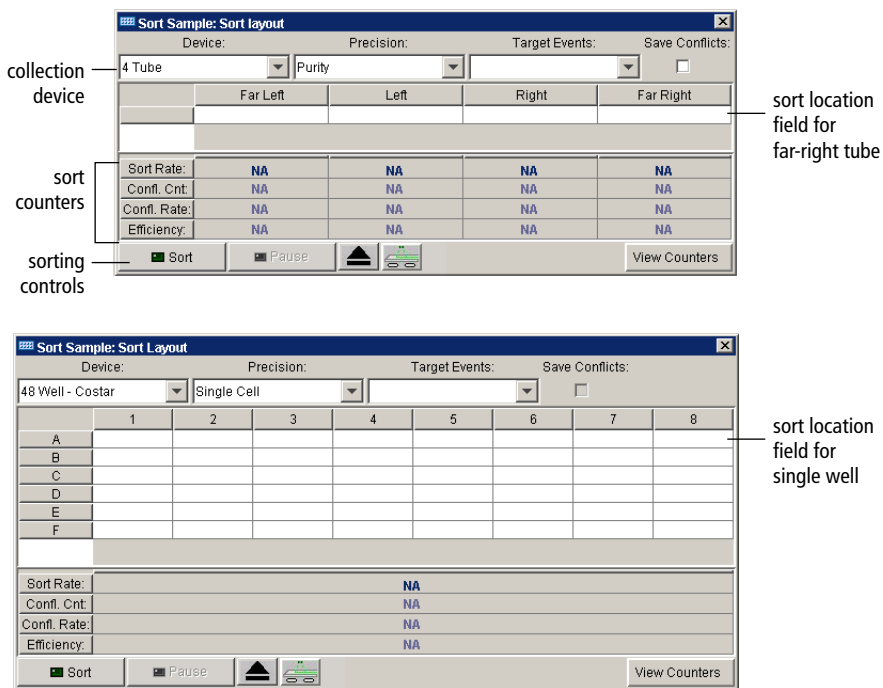

Figure 3-5 Sort Layout for collection tubes (top) and for 48-well plate (bottom)

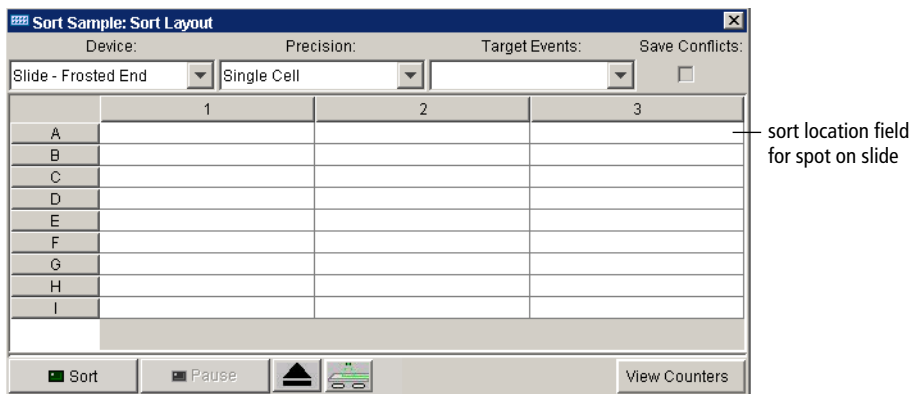

Figure 3-6 Sort Layout for frosted slide

Setting Up a Sort Layout

NOTICE If an Acquisition Template is displayed in the Worksheet frame when you create a new Sort Layout, the Sort Layout will be added to the Acquisition Template, rather than the Tube. To add a Sort Layout to a Tube, switch to the Worksheet view and click on the Tube icon in the Browser *before* creating the Sort Layout.

- 1 Right-click on a Tube in an open Experiment and choose New Sort Layout.

Alternatively, select a Tube in the Browser and click the Sort Layout button in the Workspace toolbar (.

- 2 In the Sort Layout window, choose the type of device from the Device menu.

Default sorting devices are listed along with any defined custom devices. The Sort Layout window changes depending on the selected device: the number of rows and columns in the window matches the number of tubes, wells, or spots in the collection device.

- 3 Choose the Sort Precision mode from the Precision menu.

For more information, see Sort Precision Modes on page 73.

- 4 Enter the number of events to be sorted in the Target Events field.

Once defined, the number of events can be reused by choosing from the drop-down menu. For continuous sorting, choose Continuous from the Target Events menu.

- 5 Select the field(s) corresponding to the tube(s), well(s), or spot(s) where the population will be sorted and choose a defined population from the Add menu.

After you click in a sort location field, a menu appears where you can choose to add, delete, or clear all populations in the field (Figure 3-7).

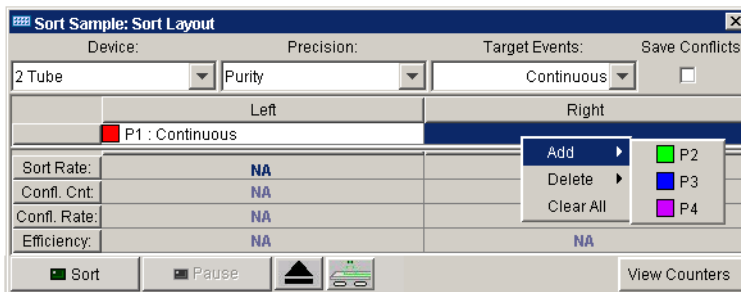

Figure 3-7 Adding populations to be sorted

After you add a population, the population and the number of target events are written to the corresponding sort location field.

- ☑ **Tip** Select a row or column header to select all fields in that row or column. After adding a population, it will be written to all selected fields at once.

- 6 Specify whether to save sort conflicts by selecting the Save Conflicts checkbox.

This checkbox is enabled only when using a two- or four-tube layout. When selected, all sort conflicts are sorted into a default location.

- For a two-tube layout, conflicts are sorted to the right; no other populations can be sorted to the right-most tube.

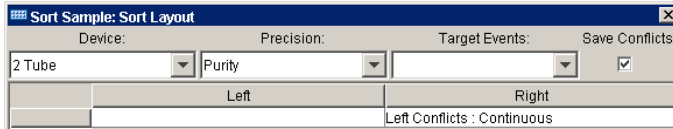

- For a four-tube layout, conflicts for the Far Left tube are sorted to the left; conflicts for the Far Right tube are sorted to the right. No other populations can be sorted into the center-most tubes.

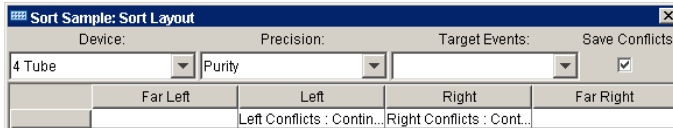

Editing a Sort Layout

- To change the number of events for any population, click on the Sort Location field(s) containing the population, and then choose a number from the Target Events field or enter a new number.
- To remove a population from a sort location field, select the field, and then choose the corresponding population from the Delete menu.
- To clear all populations from a field, select the field, and then choose Clear All.

Using Sorting Controls

Sorting controls appear at the bottom of the Sort Layout window. Use these controls for the following functions.

- Sort—starts sorting events for the current acquisition Tube. All counters reset to zero when this button is clicked. Events are sorted until the requested number of sorted events has been reached.

Click the Sort button again to stop sorting before reaching the requested number of events; the counters stop at the number of sorted events. If you click Sort to restart sorting, the counters reset to zero.

- **Pause**—stops sorting, but not acquisition; sort counters freeze when the Pause button is clicked. Click the Pause button again to continue sorting and to continue incrementing the sort counters.
- **Access Stage**—when the ACDU stage is in the back, brings the stage forward to put a plate on or take a plate off the stage. When the stage is in the front, sends the stage to the back and out of the way so you can install a collection tube holder.
- **Aspirator drawer**—moves the aspirator drawer in or out depending on its current state. The default state is in. For more information, see Aspirator Drawer on page 33.

Using Counters

Counters provide ongoing status during sorting; the fields cannot be edited. To display fewer counters in the Sort Layout window, click the View Counters button and choose a menu option. The corresponding counter is hidden. (Only counters with a checkmark next to the name are displayed.)

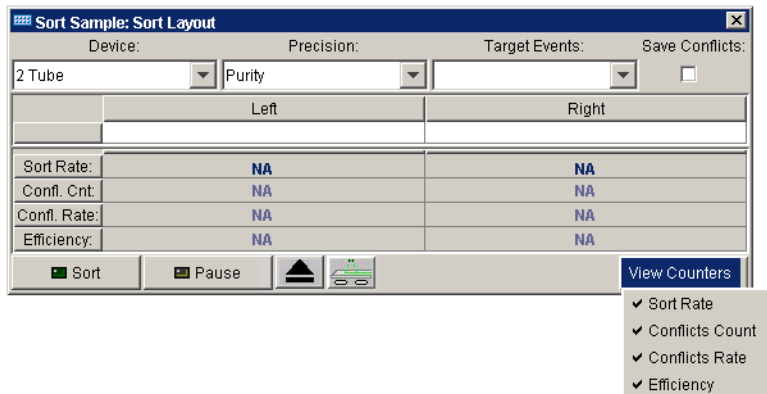

Counters display the following information:

- Sort Rate—number of events/second that met the sort criteria and were sorted
- Conflict Count—number of events that met the sort criteria but were not sorted because of conflicts
- Conflict Rate—number of conflicts/second
- Efficiency—number of sorted events/(sort conflicts + sorted events) x 100

Monitoring a Sort

During sorting, each sort location field displays the number of actual sorted events. When a target number is specified, the field displays the actual number of events along with the number of target events (Figure 3-8).

A progress bar appears behind the Sort Rate counter field showing the progress of the sort.

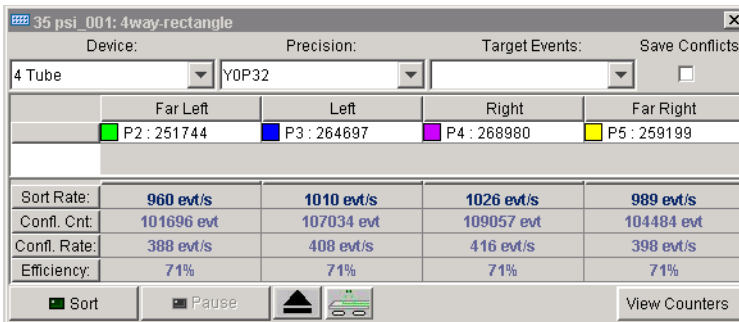

Figure 3-8 Sort Layout during sorting

Sort Report

Choose Sort > Sort Report to view a report of the current Sort Layout. This menu item is enabled only if a Sort Layout is open and the instrument is not sorting. The Sort Report can be printed or exported.

- Tip** To save counter information, print a Sort Report immediately after sorting. When you close the Sort Layout, all counter information is lost.

A Sort Report contains the following:

- Header information—Tube name, Sort Layout name, type of collection device, and the date and time of printing
- Sort settings—Sort Setup values, precision mode, and masks definition
- Acquisition counters—Threshold count, processed events count, electronic conflicts count, and elapsed time
- Sort counters—counter values per sort destination, or total sort count if sorting sequentially
- Sort Layout—Population(s), sort count, and target event count for each sort location field

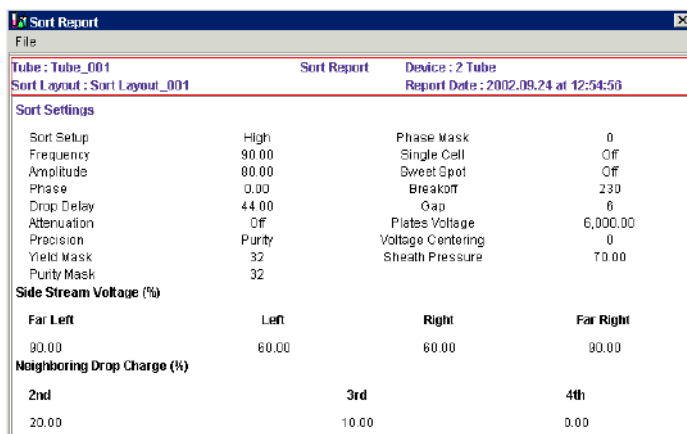

Sort Report			
Tube : Tube_001		Sort Report	Device : 2 Tube
Sort Layout : Sort Layout_001		Report Date : 2002.09.24 at 12:54:56	
Sort Settings			
Sort Setup	High	Phase Mask	0
Frequency	90.00	Single Cell	Off
Amplitude	00.00	Sweet Spot	Off
Phase	0.00	Breakoff	230
Drop Delay	44.00	Gap	6
Attenuation	Off	Plates Voltage	6,000.00
Precision	Purity	Voltage Centering	0
Yield Mask	32	Sheath Pressure	70.00
Purity Mask	32		
Side Stream Voltage (%)			
Far Left	Left	Right	Far Right
90.00	60.00	60.00	90.00
Neighboring Drop Charge (%)			
2nd	3rd	4th	
20.00	10.00	0.00	



The Sort Report window contains a File menu where you can choose to print or export the report. Exported comma-separated value (CSV) files can be opened with a spreadsheet application such as Microsoft Excel.

4

Running Samples

The following topics are covered in this chapter:

- Starting Up the Instrument on page 100
- Instrument Quality Control on page 105
- Sample Optimization Using Instrument Setup on page 121
- Recording and Analyzing Data on page 129

Starting Up the Instrument

Follow these steps to start up your BD FACSAria cell sorter.

- 1 Turn on the instrument main power; ensure that the lasers are off.

If the instrument was just shut down, wait until the system is fully depressurized (stops hissing) before you turn on the main power.

⚠ NOTICE Do not turn on the lasers until you have activated the stream. Running the lasers without activating the stream can degrade the performance of the cuvette flow cell.



Figure 4-1 Power panel

- 2 Start up the computer; launch BD FACSDiVa software.

To start the software, double-click the application shortcut on the desktop.

- 3 Verify fluidics levels in the Instrument frame; replenish fluids or empty the waste, if needed.

To display the Instrument frame, click the Instrument button in the Workspace toolbar (). Verify fluid levels at the bottom of the frame.



To service the fluid containers, see Setting Up the Fluidics Cart on page 102 and Emptying the Waste on page 104.

- 4 From the BD FACSDiVa Instrument menu, choose Fluidics Startup; click OK at the prompt.

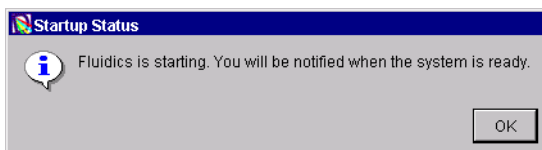

The Fluidics Startup procedure removes DI water from the plenum tanks and fluid lines and replaces it with sheath fluid.

- 5 When the Fluidics Startup procedure is complete, use software controls to start the stream.

- Click the Sorting button in the Workspace toolbar () to display the Breakoff and Side Stream windows.
- Click the Stream button in the Breakoff window to turn on the stream.

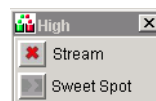

- 6 Check the stream position in the waste aspirator and inspect the stream image in the Breakoff window.

The stream should flow smoothly from the nozzle into the center of the waste aspirator. Drops should appear uniform and evenly spaced.

If the stream is flowing but it is unsteady, open the flow cell access door and check for bubbles in the flow cell. If you see bubbles, turn off the stream, wait a few seconds, and turn on the stream again.

If you see any dripping or spraying or the stream image appears abnormal, turn off the stream and go to Troubleshooting the Stream on page 204.

- 7 Turn on the lasers; wait 30 minutes for the lasers to warm up.

To turn on a laser, press the corresponding laser power button in the power panel. See Figure 4-1 on page 100.

✓ **Tip** If you are using temperature control, start heating or cooling the sample injection chamber or the recirculating water bath while the lasers are warming up. See Sample Temperature on page 82 or xxx.

8 Choose Sort > Sort Setup and verify the setup mode, or choose a new mode.

For information about Sort Setup modes, see Sort Setup on page 89.

Setting Up the Fluidics Cart

✓ **Tip** Check the fluid levels in the sheath and waste containers every time you use the instrument. This ensures that you will not run out of sheath fluid during an experiment and that the waste container will not overflow. Fluidics level indicators are shown in the Instrument frame in BD FACSDiVa software.

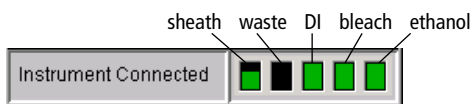

If a fluidics container is running low, refill it with the fluid indicated on the container label. For best results, fill the containers only with the fluids shown in Table 4-1. For ordering information, see Reagents on page 229.

For instructions on emptying the waste, see page 104.

Table 4-1 Recommended fluids

Container	Compatible Fluid	Capacity
Sheath	<ul style="list-style-type: none">BD FACFlow solution (non-sterile) or1X phosphate-buffered saline (PBS), with or without preservatives	Two 10-L containers or one 20-L cubitainer
Bleach	<ul style="list-style-type: none">10% household bleach (0.5% sodium hypochlorite) orBD FACSClean™ solution	5 L
DI	Deionized water	5 L
Ethanol	70% solution diluted in DI or laboratory-grade water	5 L

Refilling Containers

You can refill a container directly on the fluidics cart without detaching any lines, or you can detach the container for refilling. Note that during operation, you can add fluid to a container through the large cap without any interruption to your experiment, but if you detach any lines, you will need to prime the system.

- 1 (Optional) Disconnect the container's sensor and quick-release connector if you need to move the container (Figure 4-2).

If you do not need to move the container, skip to step 2.

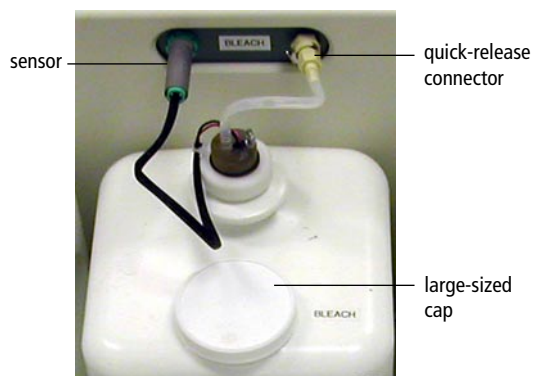

Figure 4-2 Fluidics container lines

- 2 Remove the large-sized cap from the container (Figure 4-2).
- 3 Fill the container with the fluid indicated on the container label.
- 4 Replace the container cap and hand-tighten it until it is fully closed.
- 5 Reconnect the sensor and quick-release connector to their respective ports, if needed.

Connect the lines if they were disconnected in step 1; see Figure 4-2.

⚠ NOTICE To ensure that the appropriate solutions are dispensed, do not switch tank positions. Make sure the label on each container matches the labelled port on the fluidics cart.

6 Prime the fluidics system if you disconnected the fluid lines in step 1.

From the BD FACSDiVa main menu, choose Instrument > Cleaning Modes > Prime After Tank Refill.

Emptying the Waste

WARNING All biological specimens and materials coming into contact with them can transmit potentially fatal disease. To prevent exposure to biohazardous agents, expose waste container contents to bleach (10% of total volume) before disposal. Dispose of waste in accordance with local regulations. Use proper precaution and wear suitable protective clothing, eyewear, and gloves.

- 1 Disconnect the waste container's sensor and quick-release connector from their respective ports on the fluidics cart.



- 2 Remove the large-sized cap from the container and dispose of the waste.
- 3 Add approximately 1 L of bleach to the waste container.
- 4 Replace the container cap and hand-tighten it until it is fully closed.
- 5 Reconnect the sensor and quick-release connector to their respective ports.

Instrument Quality Control

Before you run samples on the cytometer, you will want to optimize PMT voltage settings and ensure that the Laser Delay and Area Scaling values are appropriate for your experiment.

This section describes how to set up a quality control (QC) Experiment, how to verify the Laser Delay and Area Scaling values, and how to record parameter means and CVs for a fluorescent bead. For examples of fluorescent particles that can be used in this experiment, see Instrument Setup Particles on page 228.

Note that when the Experiment and QC sample are constant, changes in the recorded means and CVs indicate variations in instrument performance over time. QC data should be analyzed for trends over 30–60 runs.

NOTICE QC results are affected by laser and fluidics performance. BD strongly recommends following the laser and fluidics maintenance procedures in Chapter 7.

Setting Up the Experiment

The steps in this section show you how to set up an Experiment for instrument QC. If you have already created a similar Experiment, you can reuse it by duplicating the most recent Specimen. See Reusing the Experiment on page 120.

- 1 Choose Instrument > Instrument Configuration and verify the current configuration.

Make sure the configuration lists appropriate parameters and that the lasers and detectors reflect the setup of the detector arrays.

 **NOTICE** For accurate data results, the instrument optics setup must match the current Instrument Configuration.

- 2 Deselect all options in General User Preferences.

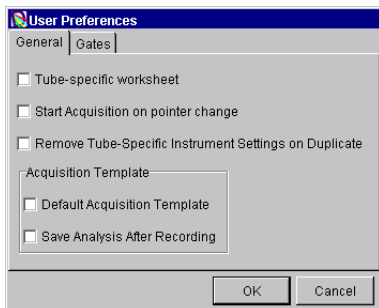

- 3 Click the corresponding tools in the Workspace toolbar to display the Browser, Instrument, Inspector, Worksheet, and Acquisition Controls frames, as needed.



- 4 (Optional) Create a folder for your Experiment.

Select the top-level *Experiments* icon in the Browser; press Ctrl-N to add a new folder.



Rename the folder with your name. Alternatively, you can name the folder *Instrument QC* or you can create an *Instrument QC* folder inside another folder. Refer to the *BD FACSDiVa Software User's Guide* for ideas on how to organize Experiments.

- Tip** To place an Experiment inside a folder, select the folder before you create the Experiment.
- 5 Press Ctrl-E to create a new Experiment; rename the Experiment with an appropriate name.

For example, use the current month and year, *Instrument QC*, or the operator's initials followed by an appropriate identifier.

- 6 Rename the new Specimen with today's date; rename the first Tube *Blue*.

This Tube will be used to measure signals from the blue laser.

- 7 Select the Blue Tube in the Browser and click on the Instr. Settings > Parameters tab in the Inspector.

- 8 Deselect the Log checkboxes for all fluorescent parameters, and select the Height checkbox for any fluorescent parameter.

When you select one checkbox for Height (H), the checkboxes for all other fluorescent parameters are also selected.

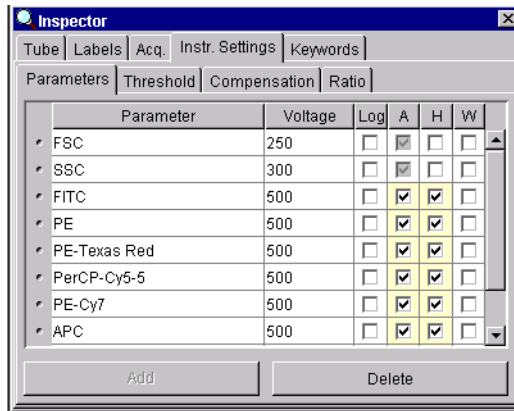

- 9 Click the Next button in the Acquisition Controls frame to create an additional Tube for each laser.

For example, if you have a three-laser system, create a Red Tube and a Violet Tube. Your Experiment should look similar to that shown in the following figure.

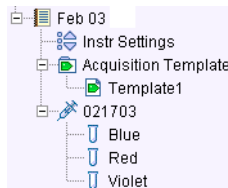

- 10** Use the Experiment Layout dialog box to set the Events to Record to 10,000 evt for all Tubes in the Experiment.
- Choose Experiment > Experiment Layout, and click the Acquisition tab.
 - Select all three Tubes.
 - Choose 10,000 from the Events to Record drop-down menu.

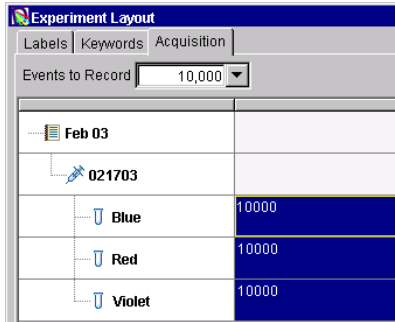

Setting Up an Acquisition Template

Next, you need to create plots to display data. In BD FACSDiVa software, plots can be set up on worksheets or Acquisition Templates. Acquisition Templates are useful when you want to reuse the same set of plots to display data from multiple Tubes. Refer to the *BD FACSDiVa Software User's Guide* for more information about Acquisition Templates.

This section describes how to set up three Acquisition Templates; each one will be used to display data from one laser.

- 1 Create an Acquisition Template by selecting the Acquisition Template tool in the Browser toolbar ().
- 2 Select the template (Template 1) in the Browser and rename it *Blue*.
- 3 Select the Blue template in the Browser and create appropriate plots for the blue laser.

NOTICE Make sure the Worksheet frame is displaying the template view before you create any plots. If necessary, click the Template button in the Worksheet toolbar () to switch to the Template view.

For example, create the following plots for the blue laser:

- FSC vs SSC dot plot
- Histograms for FSC-A, FITC-A, FITC-H, PE-A, PE-Texas Red-A, PerCP-Cy5.5-A, and PE-Cy7-A

Tip Use the sticky buttons feature to easily create multiple plots. Press the Control key, select a plot tool, and click multiple times on the worksheet. Each click will create a new plot. To deselect the plot tool, select another tool or press the Esc key.

- 4 Resize the plots so they fit on one page.

To display page breaks, click on the template background and select the Show Page Breaks checkbox in the Inspector.

Tip To resize multiple plots simultaneously, resize one plot and then select all the plots you want to change. Select the resized plot last so that it has yellow selection handles. Click the Resize tool in the Worksheet toolbar () to make all plots the same size as the selected plot.

- 5 Right-click the Blue template in the Browser and choose Create Statistics View.

6 Edit the Statistics view.

- Click Edit Statistics View in the Inspector.
- Select the Populations tab and deselect the checkboxes for #Events and %Parent.

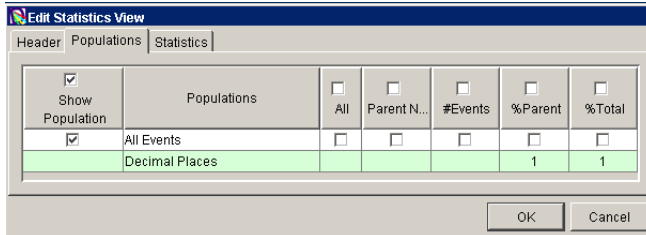

- Set up the Statistics tab to display the mean and CV for FSC and each fluorescence-A channel.

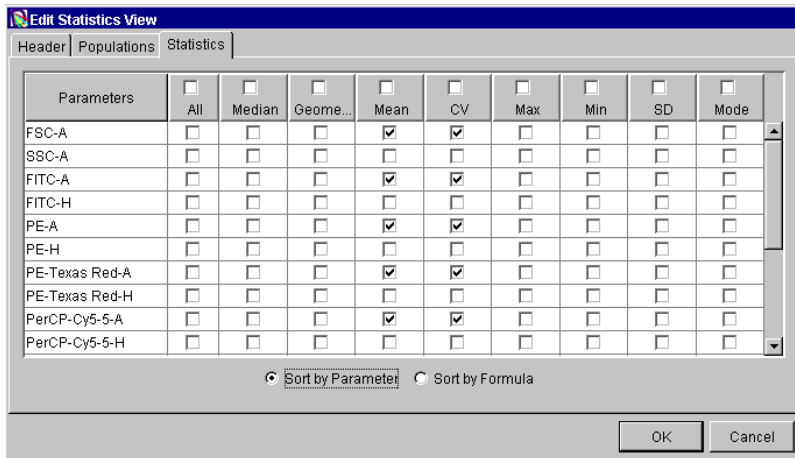

- Verify that Decimal Places is set to 1 for the CVs and 0 for the means.
- Click OK.

7 Create other templates for the red and violet lasers.

8 Create appropriate plots and Statistics views on the Red and Violet templates, respectively.

For example, create the following plots for the red laser:

- FSC vs SSC dot plot
- APC-A, APC-H, and APC-Cy7-A histograms

An example of a Red laser template is shown in the following figure.

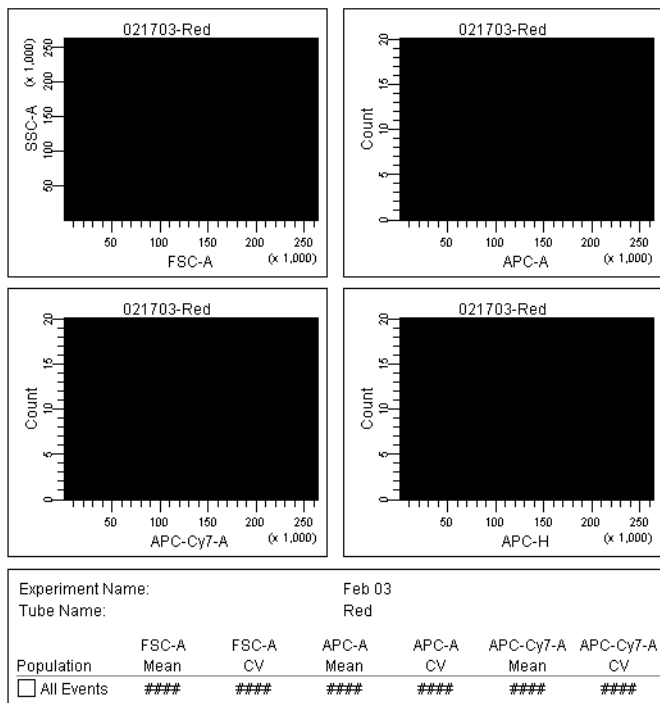

Verifying Area Scaling and Laser Delay

Since the stream position is fixed and the laser paths are aligned on the stream, laser signal should remain constant from day to day. However, different sheath pressures and nozzle sizes can impact the laser delay and area signal.

Each Sort Setup option inputs approximate Area Scaling and Laser Delay values for the corresponding sheath pressure. You should verify the settings each time you change the sheath pressure and each time the nozzle is changed.

This section describes how to optimize area scaling and laser delay, and how to optimize PMT voltages for the signal from each laser.

Optimizing Signal from the Blue Laser

BD FACSDiVa software uses area as its default parameter. The area measurement provides a complete measurement of the voltage pulse, but it can be affected by the sheath pressure. To ensure that each detector works within its linear dynamic range, it is important to adjust the height and area measurements to the same magnitude. Refer to the *BD FACSDiVa Software User's Guide* for more information about area scaling.

- 1 Double-click the Blue template icon in the Browser and verify that the green Acquisition pointer is in front of the Blue Tube.
- 2 Install the tube containing fluorescent particles for the blue laser onto the loading port; click Load in the Acquisition Controls frame.
- 3 Set the Flow Rate to 1.0.

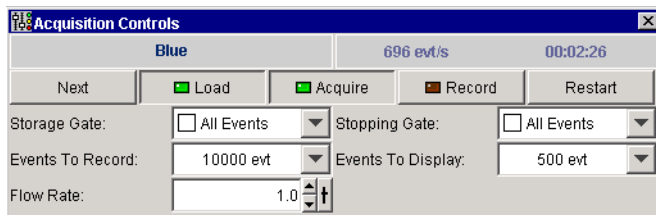

- 4 Adjust the FSC gain and the SSC voltage to place the particles on scale in the FSC vs SSC dot plot.
 - Select the Blue Tube in the Browser.
 - Click the Instr. Settings tab in the Inspector, and then click the Parameters tab.
 - Click the up and down arrows or drag the sliders to adjust the values.
- 5 Draw a region around the singlet population.

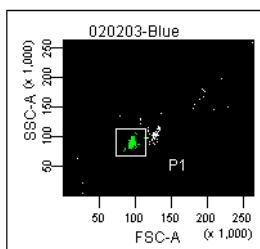

- 6 Select all histograms on the Blue template, and select the P1 checkbox in the Inspector.

The histograms change to display data from only the Singlet population.

- 7 Adjust the FITC voltage to place the FITC-H signal at approximately 100×10^3 .
- 8 Verify area scaling for the blue laser and adjust it, if needed.

The FITC-A intensity should match that in the FITC-H plot.

To adjust the intensity, click the Laser tab in the Instrument frame, select the current Area Scaling value, and enter a new value. View the result of your change in the histogram plots. See Figure 4-3 on page 114 for an example.



Figure 4-3 Blue laser area scaling before (left) and after (right) adjustment

9 Optimize the PMT voltage for each fluorescent parameter.

Adjust the voltage to achieve a signal of approximately 100×10^3 in the corresponding fluorescence histogram, as shown in Figure 4-4 on page 117.

Recording and Analyzing Data

- 1 Click Record.
- 2 After all data has been recorded, click Unload and remove the tube.
- 3 Draw an Interval gate around each peak on the scatter and fluorescence histograms.
- Tip** Ctrl-Click the Auto-Interval Gate tool and create all Interval gates. Then press Escape to deselect the button, and adjust the gates as needed.
- 4 Use the Population Hierarchy to rename each population defined by the Interval gates.

To display the Population Hierarchy view, right-click the Blue Tube and choose Show Population Hierarchy. Select a population in the Hierarchy view and enter a new name to change it. For example, change P2 to FSC, P3 to SSC, P4 to FITC, and so on.

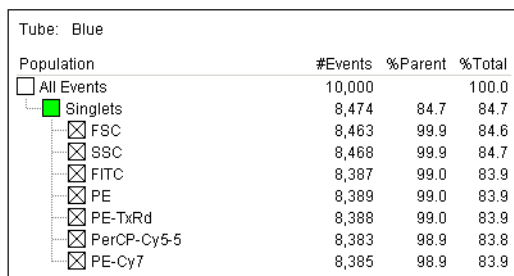

Population	#Events	%Parent	%Total
<input type="checkbox"/> All Events	10,000		100.0
<input checked="" type="checkbox"/> Singlets	8,474	84.7	84.7
<input checked="" type="checkbox"/> FSC	8,463	99.9	84.6
<input checked="" type="checkbox"/> SSC	8,468	99.9	84.7
<input checked="" type="checkbox"/> FITC	8,387	99.0	83.9
<input checked="" type="checkbox"/> PE	8,389	99.0	83.9
<input checked="" type="checkbox"/> PE-TxRd	8,388	99.0	83.9
<input checked="" type="checkbox"/> PerCP-Cy5-5	8,383	98.9	83.8
<input checked="" type="checkbox"/> PE-Cy7	8,385	98.9	83.9

- 5 Edit the Statistics view to show only the named populations.

Right-click the Statistics view and choose Edit Statistics View. Click on the Populations tab and deselect the checkbox for the All Events population.

6 (Optional) Print the instrument settings or the Instrument Status report.

The instrument settings printout contains a record of the PMT voltages and compensation settings; the Instrument Status report includes the sheath pressure and flow rate, lasers used, Laser Delay and Area Scaling settings, and the Window Extension, in addition to the instrument settings.

The Laser Delay and Area Scaling settings for a recorded Tube can also be viewed on the Tube tab of the Inspector.

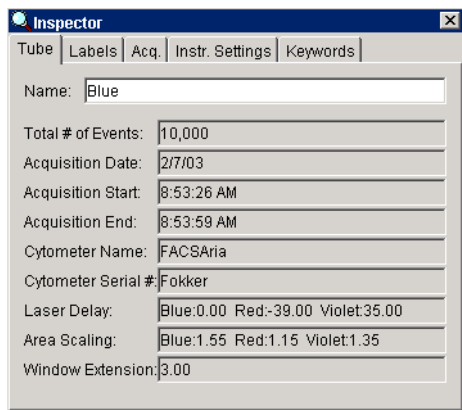

7 (Optional) Print the data on the Blue template.

See Figure 4-4 on page 117 for an example.

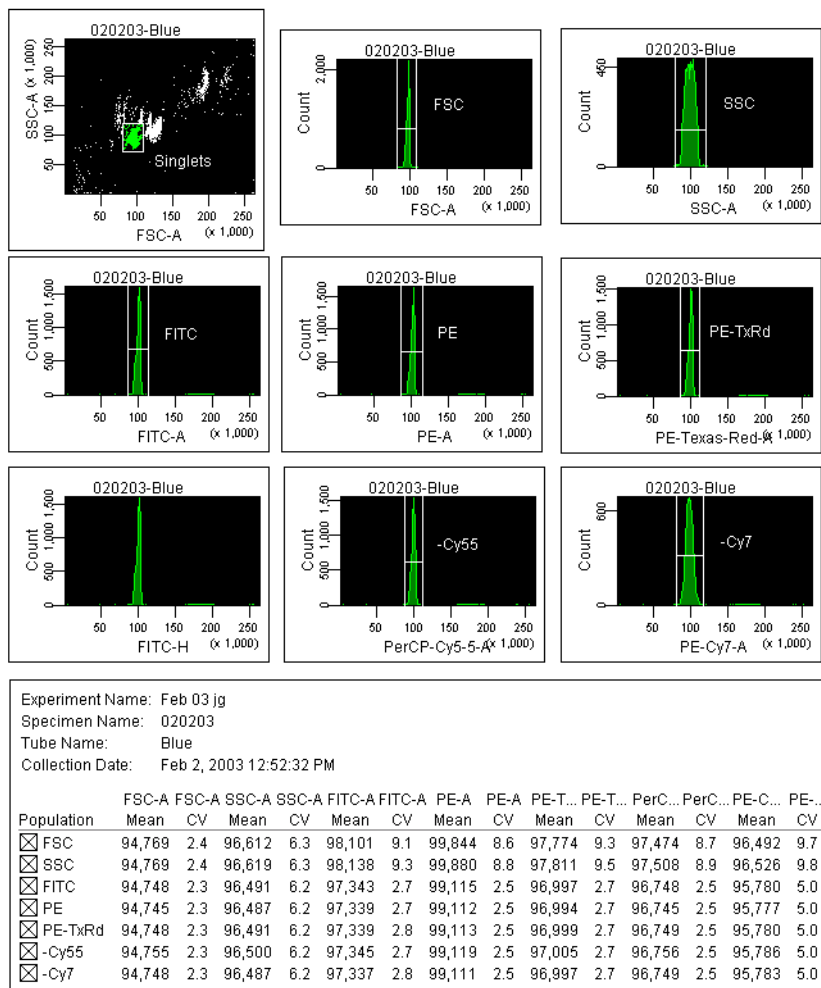

Figure 4-4 Blue laser data (example)

Optimizing Signal from the Red Laser

- 1 Double-click the Red template icon and move the Acquisition pointer to the Red Tube in the Browser.
- 2 Install the tube containing fluorescent particles for the red laser onto the loading port; click Load in the Acquisition Controls frame.
- 3 Set the Flow Rate to 1.0.
- 4 Adjust the FSC gain and the SSC voltage to place the particles on scale in the FSC vs SSC dot plot.
- 5 Draw a region around the singlet population.
- 6 Select all histograms on the Red template, and select the P1 checkbox in the Inspector.

The histograms change to display data from only the Singlet population.

- 7 Adjust the APC voltage to place the APC-H signal at approximately 100×10^3 .
- 8 Optimize the Delay setting for the red laser.

Laser Delay settings vary depending on the sheath pressure—the delay time is shorter at higher sheath pressures. Adjust the delay to synchronize laser signals in time. The delay has been properly adjusted when the fluorescent signal intensity is at its highest.

- Draw an Interval gate around each peak on the fluorescence histograms.
- Select the Laser tab in the Instrument frame. Change the Window Extension to zero to capture pulses within the narrowest time window.
- Adjust the red laser Delay setting in increments of 0.1 to obtain the highest mean channel for the fluorescent populations (Figure 4-5 on page 119).

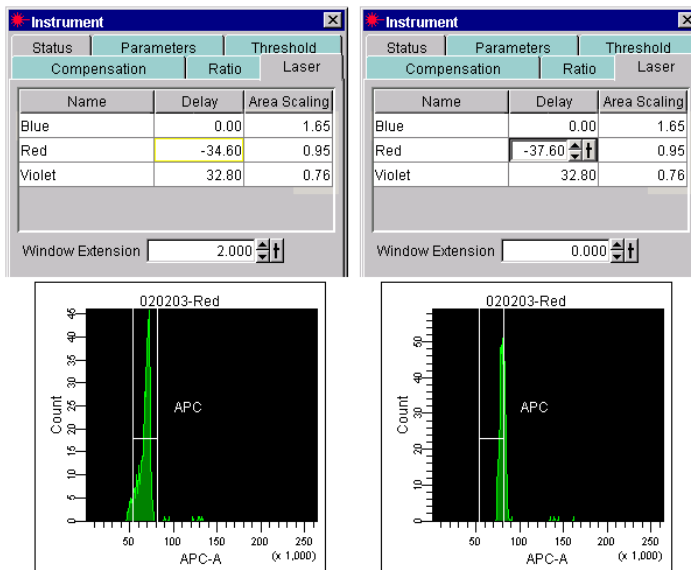

Figure 4-5 Second laser delay before (left) and after (right) adjustment

- Reset the Window Extension to the appropriate setting (typically 2). A larger Window Extension allows more flexibility for capturing pulses.

9 Verify area scaling for the red laser and adjust it, if needed.

Adjust area scaling until the APC-A intensity matches that in the APC-H plot. To adjust the value, select the current value and enter a new value. View the result of your change in the histogram plots. See Figure 4-3 on page 114 for an example.

10 Optimize the PMT voltage for each fluorescent parameter.

Adjust the voltage to achieve a signal of approximately 100×10^3 in the corresponding fluorescence histogram.

11 Record and analyze data for the red laser.

Repeat the steps listed under Recording and Analyzing Data on page 115, substituting appropriate parameters for the parameters listed.

Optimizing Signal from the Violet Laser

Repeat the steps in Optimizing Signal from the Red Laser on page 118, using plots and parameters appropriate for the violet laser.

Reusing the Experiment

To reuse this Experiment, do the following.

- 1** Open the instrument QC Experiment.
- 2** Right-click the most recent Specimen and choose Duplicate without Data.
The three QC Tubes appear under the new Specimen.
- 3** Rename the Specimen with the current date.
- 4** Double-click the Blue template to display the plots; move the Acquisition pointer to the Blue Tube.
- 5** Continue with the QC procedure.
 - For the blue laser, verify the area scaling and adjust the PMTs.
 - For the red and violet lasers, verify the laser delay and area scaling, and adjust the PMTs.

Sample Optimization Using Instrument Setup

Before you collect data for a stained sample, you need to optimize instrument electronics for your sample type.

Sample optimization consists of five main steps; each step is explained in greater detail in the sections that follow. It is important that you perform these steps in the order in which they are listed. You might need to vary certain steps for different sample types.

- 1** Create an Experiment, specify parameters, and add compensation Tubes.
- 2** Adjust the FSC and SSC voltages and the FSC threshold.
- 3** Gate the population of interest.
- 4** Adjust fluorescence detectors.
- 5** Calculate compensation.

This section describes how to perform sample optimization using the Instrument Setup feature. Instrument Setup can be used to automatically calculate compensation settings. For more information about this feature, [refer to the *BD FACSDiVa Software User's Guide*](#). If you are performing compensation manually, not all steps will apply.

Creating the Experiment

This section describes how to verify the instrument configuration, create a folder and Experiment, specify the parameters for the assay, and add compensation Tubes.

- 1 Choose Instrument > Instrument Configuration and verify the current configuration.

Make sure appropriate parameters are listed and that the lasers and detectors reflect the setup of the detector arrays.

⚠ CAUTION For accurate data results, the instrument optics setup must match the current Instrument Configuration.

- 2 Click the corresponding Workspace tools to display the Browser, Instrument, Inspector, Worksheet, and Acquisition Controls frames, as needed.

- 3 (Optional) Press Ctrl-N to add a new folder to the Browser; rename the folder with your name.

Alternatively, you can name the folder *Sample Optimization* or you can create a Sample Optimization folder inside another folder.

☑ Tip To place an Experiment inside a folder, select the folder before creating the Experiment.

- 4 Press Ctrl-E to create a new Experiment; rename the Experiment with an appropriate name.

For example, use *5-Color Expt*, or your initials followed by an appropriate identifier.

- 5 Select the Experiment-level instrument settings in the Browser; click on the Parameters tab in the Inspector and delete any unnecessary parameters (Figure 4-6).

Click the selection button next to the parameter name(s) to select the rows; press the Delete key or click the Delete button in the Inspector.

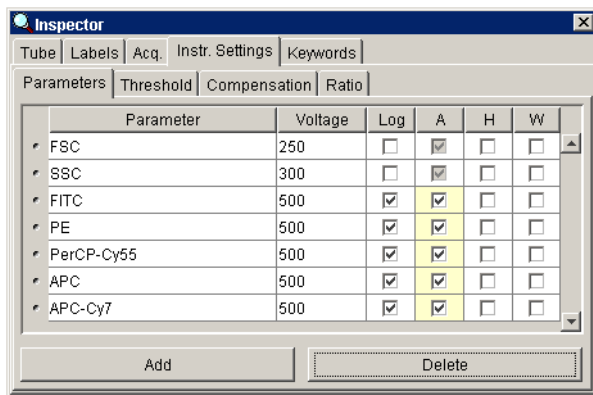
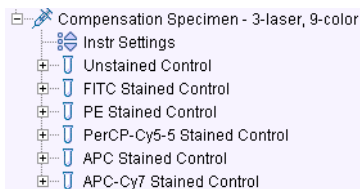

Figure 4-6 Parameters for five-color optimization

- 6 Choose Instrument > Instrument Setup > Create Compensation Tubes.

A Compensation Specimen is added to the Experiment, along with a Stained Control Tube for each parameter that was specified in step 5. Worksheets containing the appropriate plots are added for each compensation Tube.



- 7 (Optional) Create label-specific Tubes, if needed.

Label-specific Tubes are not required; they are needed only when your experiment contains samples stained with the same fluorophore conjugated to different antibodies (labels) that require different compensation values.

This is especially noticeable in tandem conjugates due to lot-to-lot variation. Refer to the *BD FACSDiVa Software User's Guide* for more information about this feature.

Adjusting the Voltages and Threshold

The unstained control will be used to check for nonspecific antibody binding; to adjust forward scatter, side scatter, and FSC threshold; to gate the population of interest (lymphocytes, in this case); and to adjust fluorescence settings.

- 1 Install the unstained control tube on the cytometer.
- 2 Verify that the green Acquisition pointer is in front of the Unstained Control Tube in the Browser; click Load.
- 3 Adjust the FSC and SSC voltages to appropriately display the scatter properties of the LWB sample (Figure 4-7).

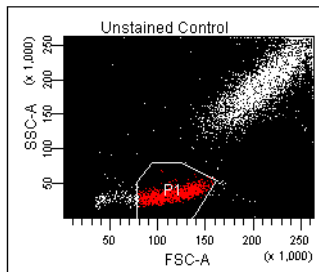

Figure 4-7 Voltages adjusted

- 4 Click the Threshold tab and adjust the FSC Threshold, if needed.

Set the threshold to remove most of the debris without cutting off the lymphocyte population (Figure 4-7).

- 5 Adjust the P1 gate on the Unstained Control worksheet to surround only the lymphocyte population (Figure 4-7).

Select the gate by clicking on the boundary. Once selected, you can drag the gate to move it, or drag any of the selection handles to change the size and shape of the gate.

- 6 Select all fluorescence histograms on the Unstained Control worksheet.
- 7 In the Plot Inspector, select the Show Grid checkbox (Figure 4-8).

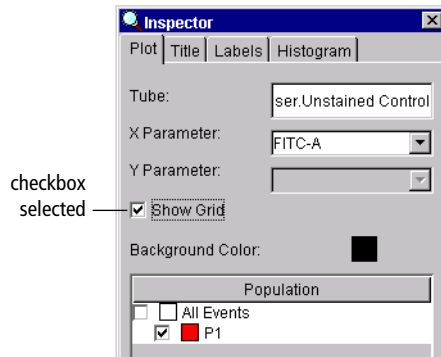

Figure 4-8 Plot Inspector for fluorescent plots

In a four-log display, values are displayed from 26–262,143. Thus, the first log decade ranges from 26–262. Gridlines are used to delineate log decades on plots.

- 8 Optimize the voltages to place the negative population for each fluorescent parameter within the first log decade (Figure 4-9).

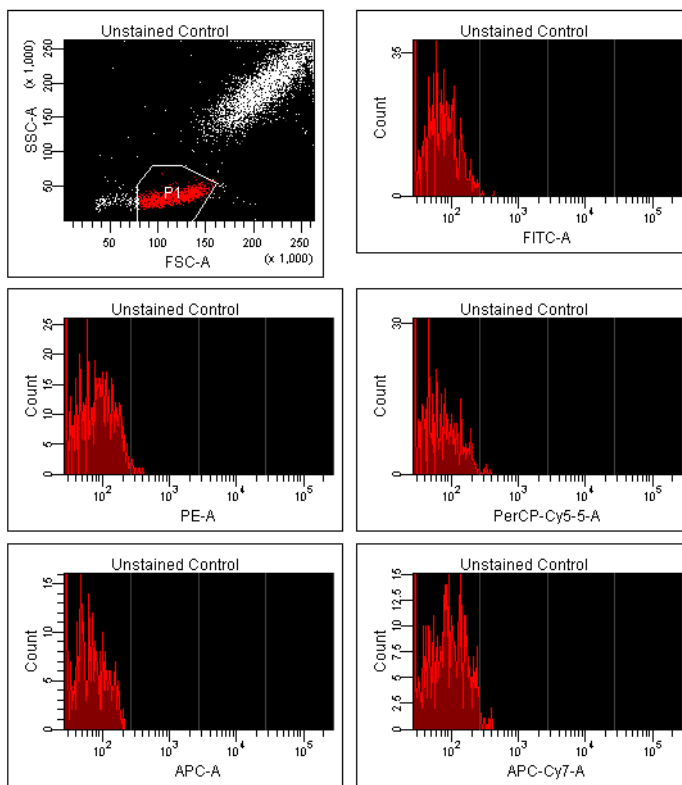

Figure 4-9 Unstained Control Tube after PMT adjustment

- 9 Click Record; when all events have been recorded, click Unload and remove the unstained control tube from the cytometer.

⚠ NOTICE Do not change the PMT voltages after the first compensation Tube has been recorded. In order to calculate compensation, all Tubes must be recorded with the same PMT voltage settings. If you need to adjust the PMT voltage for a subsequent compensation Tube, you will need to record all compensation Tubes again.

Calculating Compensation

Before you can calculate compensation, you will need to record data for each single-stained control.

- 1 Install the first stained control tube onto the cytometer.
- 2 In the Acquisition Controls frame, click the Next button, and then click Load.

Next moves the Acquisition pointer to the next Tube in the Browser. Alternatively, click to move the pointer to the next Tube.

- 3 Adjust the P1 gate to encircle the population of interest.
- 4 Ctrl-click the Acquisition pointer to record data.
- 5 When recording is finished, click Unload and install the next stained control tube onto the cytometer.
- 6 Repeat steps 2 through 5 until data for all stained control tubes has been recorded.

Now that data has been recorded, you need to create regions around the fluorescence-positive populations on the histogram for each Stained Control Tube.

- 7 Double-click the first Stained Control Tube (FITC Stained Control) to locate the corresponding plots on the worksheet.
- 8 Create an Interval gate around the fluorescence-negative and -positive populations on the histogram (Figure 4-10 on page 128).

- Tip** Use the Auto-Interval tool to quickly create an Interval gate around a population. To keep the tool selected so you don't have to click the tool for each remaining Tube, hold down the Control key the first time you click the tool. The tool remains selected until you press Esc or select another tool.

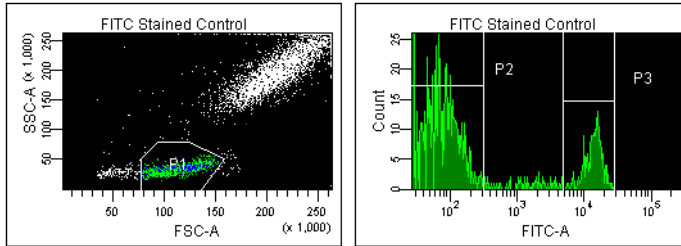

Figure 4-10 Gating the positive population

- 9** Double-click the next Stained Control Tube in the Browser to locate the corresponding plots on the worksheet.
- 10** Repeat steps 8 and 9 for the remaining compensation Tubes.

Once all regions have been set, you are ready to calculate the compensation.

- 11** Choose Instrument > Instrument Setup > Calculate Compensation.

If the calculation is successful, a dialog box appears where you can enter a name for the compensation Setup.

- 12** Enter a name for the compensation Setup; click OK.

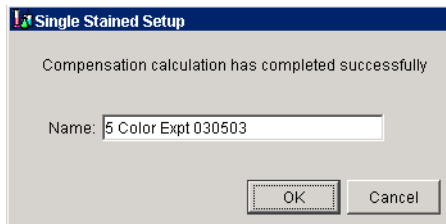

- Tip** To keep track of compensation Setups, include the Experiment name, date, or both in the Setup name.

The named Setup is automatically linked to the Experiment's instrument settings.

- Tip** Collapse the Compensation Specimen to save room in the Browser.

Recording and Analyzing Data

Once you have optimized the instrument electronics for your sample type, you are ready to record and analyze data.

During analysis, recorded data is displayed in plots, and gates are used to define populations of interest. You can use Acquisition Templates to view and optimize data before it is recorded. BD FACSDiVa software analyzes the gated data and calculates statistics that you can print or export.

This section describes how to use BD FACSDiVa software features to record and analyze sample data. As an example, data will be recorded and analyzed for two samples stained with the following reagents: CD4 FITC/CD16+CD56 PE/CD3 PerCP-Cy5.5/CD19 APC/CD8 APC-Cy7.

Two strategies are shown for reusing Analysis objects. If you are running the software on an acquisition workstation (ie, the workstation is connected to the cytometer), you can set up the analysis on an Acquisition Template, and reuse your analysis strategy for multiple samples in a run. Alternatively, Analysis objects can be copied to multiple Tubes at a time.

Setting Up the Acquisition Template

This section shows you how to use an Acquisition Template to preview and record data for multiple samples. To switch between the Worksheet and Template view, click the Template tool on the Worksheet toolbar ().

- 1 Create a new Specimen; rename the Specimen *LWB*.
- 2 Create two Tubes under the LWB Specimen; rename the Tubes appropriately.

For example, *T/B/NK_001* and *T/B/NK_002*.

- 3 Create an Acquisition Template; rename the template *Record Data*.
 - If the Default Acquisition Template is enabled in User Preferences (default option), the template is already present. Expand the Acquisition Templates folder to locate and rename the template.

- If the Default Acquisition Template preference is disabled, create a template by clicking the Acquisition Template tool in the Browser toolbar (). You can create up to ten templates per Experiment.

4 Use the Experiment Layout dialog box to define labels and to specify the number of events to record for each Tube.

Parameter labels are defined in the Experiment Layout view. Labels will appear on the plot axes and in all statistics views.

- Choose Experiment > Experiment Layout.
- On the Labels tab, enter appropriate labels for the Tube. For example, enter CD4 in the FITC field; use the Tab key to move to the next field.

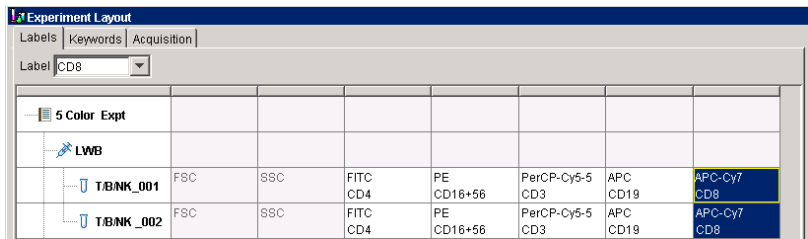

- On the Acquisition tab, enter 10,000 events for Tubes 001 and 002. Notice that the Acq. tab in the Inspector updates automatically.

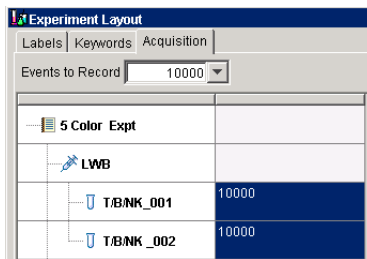

- Click OK.

5 On the Acquisition Template, create appropriate plots for previewing the data.

For example, create FSC vs SSC, FITC vs PE, PerCP-Cy5.5 vs PE, and APC vs APC-Cy7 dot plots.

- Tip** Ctrl-click the Plot tool to keep the tool selected until you create all plots.

Recording Data

Note that if the Save Analysis After Recording preference is enabled in User Preferences, a copy of the data displayed in the template will be saved with each recorded Tube. If you do not want to save a copy of the data, disable the preference.

- 1** Install the first sample tube onto the cytometer.
- 2** Move the Acquisition pointer to the first Tube; click Load.
- 3** While data is being acquired, draw a region around the lymphocytes; set the other plots to show data from the Lymphocyte population.
- 4** Ctrl-click the Acquisition pointer to record data.
- 5** When all events have been recorded, click Unload and remove the tube from the cytometer.
- 6** Install the next sample tube onto the cytometer; move the pointer to the corresponding Tube in the Browser and click Load.
- 7** Preview the data in the Acquisition Template; Ctrl-click the pointer to record data.
- 8** Repeat steps 5 through 7 until data has been recorded for all tubes.
- 9** (Optional) Print the Experiment-level instrument settings or the Instrument Status report.

To print the settings, right-click the instrument settings icon and choose Print.

Analyzing Data

This section describes how to set up plots, gates, and a statistics view to analyze the recorded data. By the end of this section, your analysis should look similar to that shown in Figure 4-11 on page 134.

- 1 Create a new Acquisition Template; rename the template *T/B/NK Analysis*.
- 2 Select the first Tube under the LWB Specimen and create the following plots on the Analysis template:
 - FSC vs SSC
 - CD3 PerCP-Cy5.5 vs CD16+56 PE
 - CD3 PerCP-Cy5.5 vs CD19 APC
 - CD3 PerCP-Cy5.5 vs CD8 APC-Cy7
 - CD3 PerCP-Cy5.5 vs CD4 FITC
- 3 Resize the plots so they fit on one page, as shown in Figure 4-11 on page 134.
- 4 Draw a gate around the lymphocytes; use the Population Hierarchy to rename the population *Lymphocytes*.
- 5 Select all plots except the FSC vs SSC plot and specify to show only the Lymphocyte population.
- 6 Select all plots and click the Title tab in the Plot Inspector; select the checkboxes to display the Tube and Population names in the plot titles.

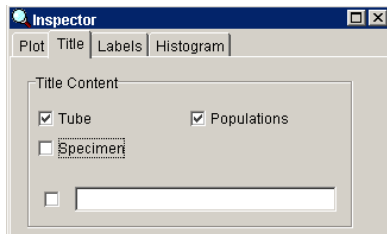

7 Create a Statistics view; edit the view to show only the Lymphocyte population and to display the mean for all fluorochromes.

8 Draw a region around the CD3-positive population on the CD3 PerCP-Cy5.5 vs CD16+56 PE plot; name the population *T Cells*.

Tip When drawing regions, be sure to include events on the plot axes.

9 Draw a region around the CD16+56–positive population on the same plot; name the population *NK Cells*.

10 Draw a region around the CD19 population on the CD3 PerCP-Cy5.5 vs CD19 APC plot; name the population *B Cells*.

11 Select the T-cell population in the Population Hierarchy view; draw a region around the double-positive population on the CD3-PerCP-Cy5.5 vs CD8 APC-Cy7 plot, and name the population *T Cytotoxic*.

Because the T-cell population is selected first, the T-cytotoxic cells become a subset of all T cells.

12 Select the T-cell population in the Population Hierarchy view; draw a region around the double-positive population on the CD3 PerCP-Cy5.5 vs CD4 FITC plot, and name the population *T Helper*.

13 Print the analysis.

See Figure 4-11 on page 134 for an example.

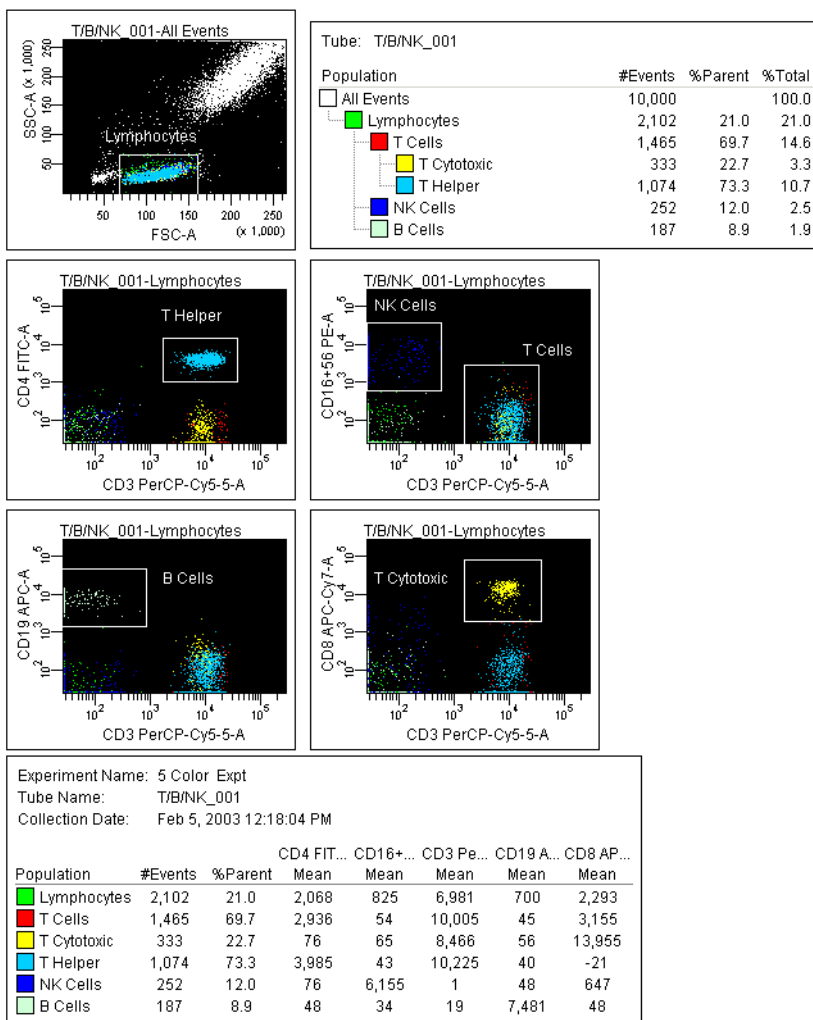

Figure 4-11 Lymphocyte analysis

Reusing the Analysis

Now that the analysis strategy has been defined, you can use it to analyze the remaining Tubes in the Experiment. Acquisition Templates allow you to apply an analysis strategy to a series of data files without saving the analysis each time. After previewing the data, you can print the analysis or save it to a Tube-specific worksheet (see the following section, Saving the Analysis).

- 1 Move the Acquisition pointer to the next Tube under the LWB Specimen.
- 2 View the data on the Acquisition Template; make adjustments to gates, as needed.

NOTICE Adjustments will also apply to the next Tube that is viewed on the template. If you don't want to alter the template, save the analysis as described in the next section and make adjustments on the Tube's worksheet.

Saving the Analysis

Since the Analysis objects were created on an Acquisition Template, the analysis will not be saved with each Tube. If you want to save a copy of the analysis with any Tube, do the following.

- 1 Expand the T/B/NK Analysis Template in the Browser.
- 2 Right-click on the Analysis object and choose Copy.

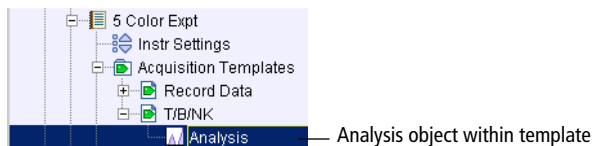

- 3 Click the Template tool on the Worksheet toolbar () to switch to the Worksheet view.

- 4 Create a new worksheet for the destination Tube; rename the worksheet appropriately.
- 5 Collapse the Tube in the Browser; right-click the Tube icon and choose Paste.

The elements on the template are copied to the new worksheet. You can view the analysis by double-clicking the Tube in the Browser.

- Tip** Apply the analysis to multiple Tubes by selecting more than one Tube before you choose Paste. Enable the *Tube-specific worksheet* user preference to automatically create a new worksheet for the pasted Analysis objects.

Note that you can automatically save a copy of the analysis with each Tube by enabling the Save Analysis After Recording preference before you record Tube data. In this case, the analysis plots are placed on the worksheet that is open at the time of recording. To control where the plots are placed, create a new worksheet before data is recorded.

Sorting

You can program BD FACSDiVa software to sort a specified number of particles from multiple populations into a variety of sorting devices, including tubes, plates, and slides. Collection devices are provided for sorting into 1-mL, 12 x 75-mm, and 15-mL tubes; hardware for sorting into plates and slides is available as an option. Up to four defined populations can be sorted into each tube, allowing up to 16 populations to be sorted at one time.

Any subsetted population can be used for sorting, including populations defined by Quadrant gates, Interval gates, or derived gates. A single sort population can be defined by up to eight gates.

The following topics are covered in this chapter:

- Setting Up for Sorting on page 138
- Determining the Drop Delay on page 145
- Sorting on page 149
- Setting Up for Sorting Into a Plate or Slide on page 153

Before you begin, you should be familiar with BD FACSAria operation using BD FACSDiVa software. Review chapters 2 and 3, if needed.

Setting Up for Sorting

In general, do the following to set up for a sorting experiment. Each step is explained in more detail in previous or subsequent sections.

1 Install the appropriate-size nozzle.

As a general guideline, the nozzle opening should be at least three times the diameter of the particle to be sorted. See *Changing the Nozzle* on page 140.

2 Start up the instrument, the computer, and the stream.

See *Starting Up the Instrument* on page 100.

When you turn on the stream, make sure it flows smoothly from the nozzle into the center of the waste aspirator. If you need help troubleshooting the stream, turn it off and go to *Troubleshooting the Stream* on page 204.

3 Choose a new Sort Setup option, if needed.

To change your current Sort Setup mode, choose High, Medium, or Low from the Sort > Sort Setup menu.

- High is designed for high-speed sorting with the 70 μm nozzle.
- Medium is designed for sorting cell lines or fragile cells with the 70 μm nozzle.
- Low is designed for single-cell sorting, ACUDU sorting, or sorting large or fragile cells with the 100 μm nozzle.

For more information, see *Sort Setup* on page 89.

4 Adjust the Ampl. control to set the required drop breakoff.

Adjust the Drop 1 value, if needed, to match the generated value. For more information, see *Setting Up the Breakoff* on page 141.

If you need help troubleshooting the drop image, see *Sorting Troubleshooting* on page 209.

- 5** Turn on the Sweet Spot when the drop pattern is stable.
- 6** Check the laser delay and the area scaling factor for your sheath pressure.
See Instrument Quality Control on page 105.
- 7** Perform sample optimization for the sample to be sorted.
See Sample Optimization Using Instrument Setup on page 121.
- 8** Install the required collection device and set up the side streams.
See Setting Up for Bulk Sorting on page 143 or Setting Up for Sorting Into a Plate or Slide on page 153.
- 9** Calculate the drop delay.
See Determining the Drop Delay on page 145.
- 10** Run the sample to be sorted and use gating tools and subsetting methods to define the population(s) of interest.
Examples of gating analysis can be found in Analyzing Data on page 132 and in the *BD FACSDiVa Software User's Guide*.
- 11** Define a Sort Layout for the Tube containing the defined sort populations and proceed with sorting.
See Sorting on page 149.

Changing the Nozzle

As a general guideline, the nozzle opening should be at least three times the diameter of the particle to be sorted. Two sizes of nozzles are provided with your instrument: 70- and 100- μm nozzles. The size is marked on the nozzle.

⚠ WARNING Any instrument surface that comes in contact with biological specimens can transmit potentially fatal disease. Use universal precautions when handling sorting hardware. Wear suitable protective clothing and gloves.

⚠ CAUTION The nozzle and the stream-charging wire conduct electrical charge during sorting. To prevent shock, do not touch the nozzle or the stream-charging wire when the voltage warning light is illuminated or any time during sorting.

To change the nozzle, do the following.

- 1 Turn off the lasers and the stream, if they are on.
- 2 Pull the stream-charging wire out of the nozzle.

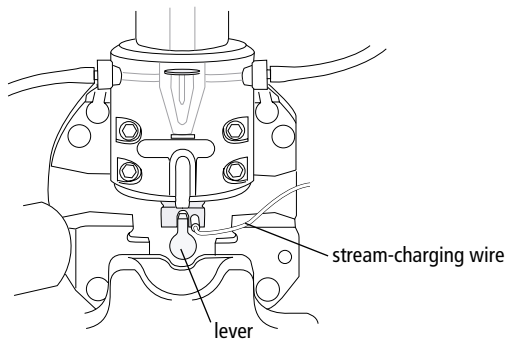

- 3 Turn the nozzle-locking lever to the left, and pull the nozzle out of the cuvette flow cell.

✓ Tip To avoid losing the O-ring, hold the nozzle steady and pull it straight out without tilting it from side to side. If you do not see the O-ring on the nozzle, it could be stuck to the cuvette. Use the wooden end of a cotton swab to locate and remove the O-ring.

- 4 Transfer the nozzle O-ring to the new nozzle or set it aside with the nozzle.
- 5 Carefully insert the new nozzle into the flow cell.

Make sure an O-ring is installed inside the groove at the end of the nozzle. Insert the nozzle at a slight downward angle to avoid contact between the O-ring and the cuvette. Push it gently all the way forward without rocking it from side to side.

- 6 Turn the nozzle-locking lever clockwise to the 12:00 position, and plug the stream-charging wire into the nozzle.
- 7 After you start up the instrument, turn on the stream and make sure it runs through the nozzle properly.
- 8 Turn on the lasers.

Note that after changing the nozzle, you might need to change the angle of the sort block to re-center the stream in the aspirator. To do so, loosen the adjustment screws on either side of the deflection plates and rotate the sort block (see Figure 1-11 on page 32). Tighten the screws when the stream is centered in the aspirator. For further assistance, see Troubleshooting the Stream on page 204.

Setting Up the Breakoff

- 1 Use the slider control to adjust the Ampl. until the drop breakoff is approximately in the center of the Breakoff window.

Do not exceed 70 volts. If you cannot achieve a drop breakoff at <70 volts, do the following:

- Check the flow cell for air bubbles. If you see bubbles, turn the stream off and back on.
- Make sure the sheath pressure and drop drive frequency are appropriate. Restore the default Sort Setup values, if needed.
- Inspect your nozzle for damage and replace it, if necessary.

NOTICE If the amplitude is <10 volts, turn on Attenuation in the Side Stream window.

- 2 Verify that the small satellite droplets are merging with the large droplets.

Satellite-merging is largely dependent on nozzle position. If the satellites are not merging, try to push gently forward on the nozzle. Use care not to move the nozzle up or down or side to side. You might need to remove and reinstall the nozzle, making sure that the nozzle is pushed fully forward before turning the locking lever.

- 3 Input the actual Drop 1 value as the target in the Drop 1 field.

The actual value appears in the gray background next to the Drop 1 field. Once a valid target has been established, you do not usually need to reset it unless you change the nozzle or your Sort Setup option.

NOTICE If the target value causes the Ampl. to exceed 70 volts, perform the recommendations under step 1 and re-input the Drop 1 target value.

- 4 Turn on the Sweet Spot when the drop pattern is stable.

The Sweet Spot monitors the breakoff and makes adjustments as necessary to maintain the breakoff throughout the day.

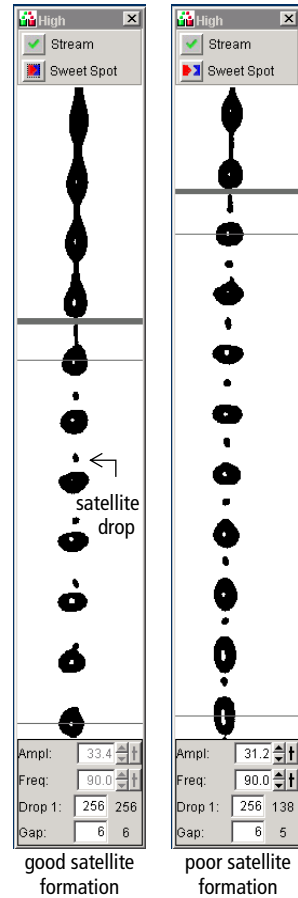

Setting Up for Bulk Sorting

This section describes how to set up the streams for two- or four-way sorting. For sorting using the ACDU option, see Setting Up for Sorting Into a Plate or Slide on page 153.

WARNING Any instrument surface that comes in contact with biological specimens can transmit potentially fatal disease. Use universal precautions when handling sorting hardware. Wear suitable protective clothing and gloves.

- 1 Install collection tubes in the required collection device.

Collection tube holders are available for 1-mL microtubes, 12 x 75-mm tubes, and 15-mL centrifuge tubes. For compatible tubes, see Labware on page 230.

- 2 Install the tube holder on the instrument.

Close the sort block door and open the sort collection chamber door, if needed. The sort block door must be closed in order to open the collection chamber door.

Slide the holder into the slotted fittings below the sort aspirator drawer, and close the sort collection chamber door.

- 3 Turn on the deflection plates.

Click the Voltage control in the Side Stream window. The voltage warning light illuminates, indicating that the plates are charged.

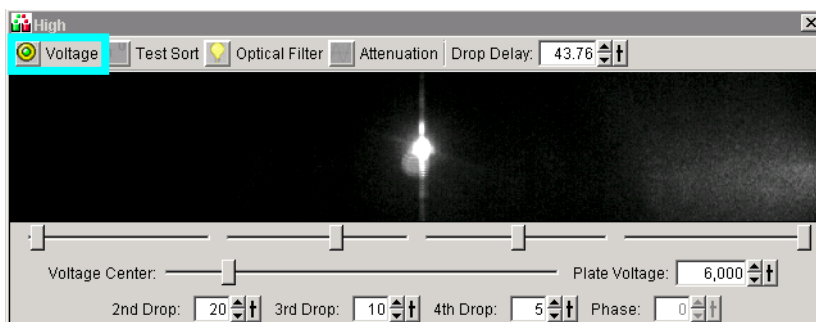

Make sure the center stream image does not move after the plates are turned on. If the stream image is off-center, use the Voltage Center slider to re-center the stream.

Major movement of the center stream could indicate that the plates or area around the plates needs cleaning. See External Cleaning on page 174.

4 Turn on Test Sort and optimize the side streams.

Adjust the voltage sliders to view the required number of streams. If you cannot see a stream image or the image is dim, adjust the micrometer dial on the BD AccuDrop laser to better view the streams (Figure 1-17 on page 41).

- For four-way sorting, adjust the four slider controls until you see four streams.
- For two-way sorting, turn off the outer streams by moving the outer slider controls all the way to the center. Adjust the inner two slider controls until you see two streams.

5 Adjust the 2nd, 3rd, and 4th Drop settings to tighten the center stream and fine-tune the side streams, if needed.

Generally, the Sort Setup mode provides good starting values for these settings. Adjust the values only if needed to optimize the streams.

6 Open the aspirator drawer and aim the side stream(s) into the bottom of each collection tube.

- Open an Experiment, if one is not already open, and create a Sort Layout for any of the Tubes.
- In the Sort Layout view, click the Aspirator Drawer button to open the drawer ()
- Open the sort block door and aim each side stream into the bottom of a tube as you adjust the corresponding slider control.

- When you are satisfied with the side stream deflection, close the sort block door.

 **WARNING** A 12,000-volt potential exists between the deflection plates when they are on. Contact with the charged plates results in serious electrical shock. Do not touch the deflection plates when the plate voltage is on. The plates remain energized even when the sort block door is opened.

- 7 Click the Voltage control () to turn off the deflection plates.

Determining the Drop Delay

BD AccuDrop technology is used to determine the optimal drop delay setting for your sorting application. For more information, see [Setting the Drop Delay](#) on page 67. Before beginning this procedure, make sure the stream is stable and the Sweet Spot is on.

Setting Up the Experiment

The steps in this section show you how to set up an Experiment for BD AccuDrop optimization. Because no data is recorded, the Experiment can be reused as often as you like.

- 1 Create a new Experiment and rename it *BD AccuDrop*.
- 2 (Optional) Rename the first Tube *BD AccuDrop Beads*.
- 3 Create an FSC histogram.
- 4 Draw an Interval gate that encloses the entire histogram.

Set the endpoints of the interval at 26 and 262,143.

 **NOTICE** For an accurate setting, ensure that the histogram region encompasses the entire histogram.

- 5 Create a Sort Layout.

- 6 Set the Precision mode to Initial and the Target Events to Continuous.

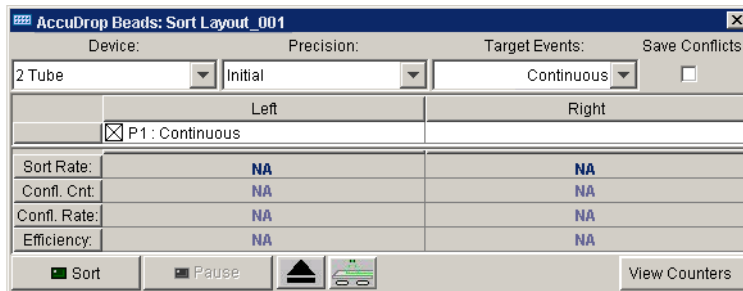

Sorting Beads to Determine the Drop Delay

- 1 Load a tube filled with a dilute suspension of BD AccuDrop beads (approximately 2 drops of beads in 0.5 mL PBS).
- 2 In the Laser tab, set the Window Extension to zero.
- 3 Adjust the Flow Rate to achieve an event rate of 2,000–4,000 events per second.

NOTICE If this cannot be achieved using a Flow Rate setting between 1 and 5, adjust the bead concentration.

- 4 Turn on the Voltage in the Side Stream window; click Sort in the Sort Layout view.
- 5 Click Cancel at the prompt to open the aspirator drawer.



There is no need to collect the beads; when the drawer is closed, the beads are sorted to waste.

- 6 Click the Optical Filter control in the Side Stream window.

This control moves the emission filter that allows you to view the BD AccuDrop beads in front of the lower camera. When the control is clicked, the image switches from a raw image to a processed (digitized) image. The two boxes indicate the region of the image where the left and center stream intensities are calculated during image processing; the numbers shown are percentages of the total intensity.

If the left side stream is not completely contained in the left region, adjust the voltage slider to place the stream in the center of the region.

- 7 Adjust the micrometer dial to obtain the brightest bead spot on the center stream (Figure 1-17 on page 41).

- 8 Optimize the drop delay.

Adjust the Drop Delay value in 1-drop increments (Ctrl-click arrow control) to achieve close to 100% intensity in the left side stream. Wait a few seconds after each click for a complete response to the Delay change.

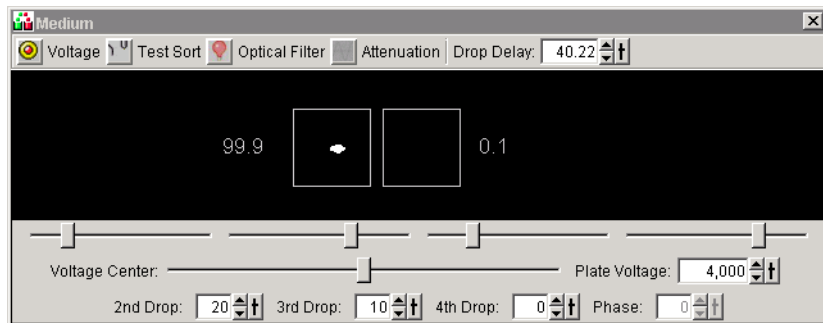

Figure 5-1 Sorting BD AccuDrop beads in Initial mode

- 9 In the Sort Layout view, change the Precision mode to Fine Tune.

10 Optimize the drop delay.

Adjust the Drop Delay value in 0.3-drop increments (click arrow control) until the left side stream intensity is $\geq 90\%$. Wait a few seconds after each click for a complete response to the Delay change.

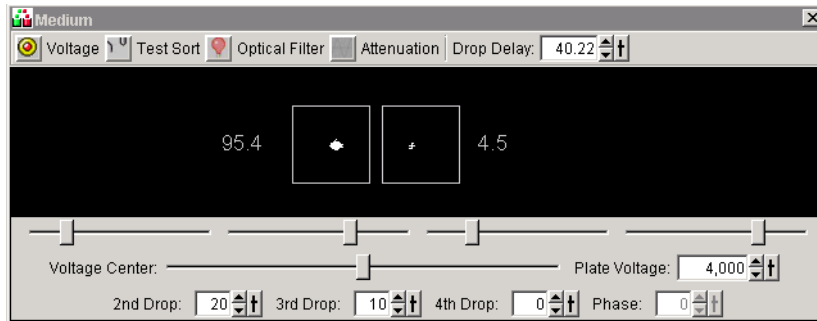

Figure 5-2 Sorting BD AccuDrop beads in Fine-Tune mode

- 11 Click the Optical Filter control to move the emission filter away from the camera.
- 12 Reset the Window Extension to its original setting (typically, 2).
- 13 Turn off the deflection plates.

Sorting

Before beginning the sort, do the following:

- Perform the steps outlined in Setting Up for Sorting on page 138.
- Use gating tools and subsetting methods to define the population(s) of interest.

NOTICE Snap-To gates cannot be used for sort gates.

Examples of gating analysis can be found in Analyzing Data on page 132 and in the *BD FACSDiVa Software User's Guide*.

Setting Up the Experiment

-  **Tip** If you are sorting into four tubes, create a Four-Way Purity Sort Precision mode. (See Defining New Precision Modes on page 75.)

When more than one drop is deflected in the same direction, residual charge from the first drop degrades the quality of the side streams. Thus, when four-way sorting or sorting into small wells where precise deflection is required, a Yield Mask of zero is recommended. For more information, see Yield Mask on page 69.

- 1 In the Browser, right-click the Tube containing the defined population subset(s) to be sorted and choose New Sort Layout.

Alternatively, select a Tube in the Browser and click the Sort Layout button in the Workspace toolbar (). By default, the 2-Tube Sort Layout appears.

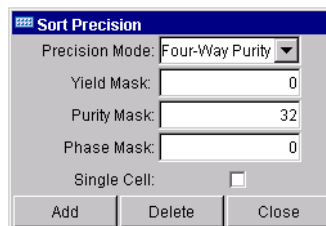

2 Make appropriate entries in the Sort Layout view.

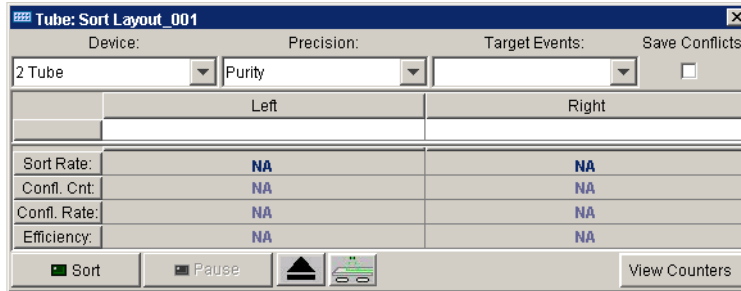

- Choose the collection device from the Device menu.
- Change the Sort Precision mode to Purity (two tubes), Four-Way Purity (four tubes), or Single Cell (plate or slide).
- Enter the number of Target Events by choosing a value from the drop-down menu or entering a number in the field.
- Select the sort location field(s) to be sorted into. Select multiple fields by dragging the mouse; select a row or column by clicking the row or column header.
- Add the required population(s) to each sort location field. If the Add menu doesn't appear after selecting the sort location field(s), right-click the selected fields to see the menu.
- Enter the number of Target Events and the population(s) for the remaining sort location fields, as needed.
- To display fewer counters in the Sort Layout window, click the View Counters button and deselect a menu option. The corresponding counter is hidden. (Only counters with a checkmark next to the name are displayed.)

Starting and Monitoring the Sort

- 1 Open the sort collection chamber door and install the collection tubes, plate, or slide.
- 2 Install the sample tube on the loading port and click Load.
- 3 Set the required Flow Rate.

Tip Sorting results are optimized at lower flow rates (<8.0).

- 4 (Optional) Turn on the deflection plates and open the aspirator drawer.

The deflection plates turn off automatically each time a tube is unloaded. If you do not turn them back on before beginning a sort, a dialog box appears where you can turn on the plates and open the aspirator drawer by clicking OK.

- 5 Verify that the green Acquisition pointer is indicating the appropriate Tube in the Browser; click Sort.
- 6 Click OK if you are prompted to open the aspirator drawer or turn on the deflection plates.

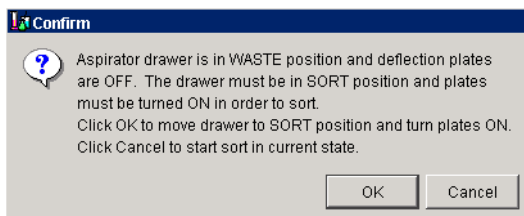

⚠ NOTICE If you click Cancel at the message prompt, sorting will begin with the deflection plates off and the drawer closed. Thus, sort populations will be identified and counted, but no deflection (or sorting) will occur. If you sort with the drawer closed, events will be sorted to waste.

Tip You can click Record to save data for the Tube. Acquisition and sorting continue when the required number of events has been recorded.

Sorting continues until the required number of cells has been sorted. Acquisition stops and the drawer closes when sorting is complete. If the number of Target Events is set to Continuous, sorting continues until you manually stop sorting by clicking the Acquire or Sort button.

Monitor the sort progress from the Sort Layout view. The number of events sorted into each sort location appears in the corresponding field. The sort rate and sort conflict rate are displayed in the corresponding counter fields.

	Far Left	Left	Right	Far Right
	P2 : 251744	P3 : 264697	P4 : 268980	P5 : 259199
Sort Rate:	960 evt/s	1010 evt/s	1026 evt/s	989 evt/s
Conf. Cnt:	101696 evt	107034 evt	109057 evt	104484 evt
Conf. Rate:	388 evt/s	408 evt/s	416 evt/s	398 evt/s
Efficiency:	71%	71%	71%	71%

Tip To pause during sorting, click the Pause button. Sort counts are retained when you restart sorting by clicking the Pause button again. If you need to unload the sample tube during sorting (ie, to add more sample), you can print a Sort Report to keep a record of the current sort counts. (The sort counts reset to zero when you restart sorting after loading a sample.)

NOTICE When the Sweet Spot is on, sorting pauses automatically if the Drop 1 or Gap are out of range. This ensures that sorting occurs only under the proper breakoff conditions. If a more severe problem such as a clog is detected, the stream shuts off and sorting stops: the deflection plates shut off, the aspirator drawer closes, and the sample tube is unloaded. To clear a clogged nozzle, see *Cleaning a Nozzle* on page 198.

Setting Up for Sorting Into a Plate or Slide

This section describes how to set up for sorting into a plate or slide. For general guidelines, see Setting Up for Sorting on page 138.

Installing the Sorting Hardware

WARNING Any instrument surface that comes in contact with biological specimens can transmit potentially fatal disease. Use universal precautions when handling sorting hardware. Wear suitable protective clothing and gloves.

- 1 Install the splash shield below the aspirator drawer.

Close the sort block door and open the sort collection chamber door, if needed. The sort block door must be closed in order to open the collection chamber door.

Remove the tube holder, if one is installed, and tilt the splash shield to insert it into the slotted fittings below the sort aspirator drawer. Push the splash shield all the way in.



splash shield



Figure 5-3 Installing the splash shield

- 2 Click the Access Stage button to bring the ACDU stage to the front.
 - Open an Experiment, if one is not already open, and create a Sort Layout for any of the Tubes.
 - In the Sort Layout view, click the Access Stage button () to move the stage to the front of the sort collection chamber.
- 3 Install the required collection device on the stage.
 - If you are sorting into a plate, install the plate with well A1 toward the front of the stage.
 - If you are sorting onto a slide, install the slide-adaptor tray with the printed side up. If your slide has a frosted end, place the frosted end to the right.



Figure 5-4 ACDU stage set up with plate (left) and slide (right)

Sorting starts on the front left corner of the device, and proceeds from front to back, and then from the left to the right side of the device, sorting in a serpentine motion. Thus, for a plate, sorting proceeds from well A1–A12, B12–B1, C1–C12, and so on.

When sorting onto a slide, sorting proceeds in rows across the short end of the slide, and in columns along the long end of the slide. Make sure that you set up your Sort Layout accordingly. See Figure 5-5 on page 155.

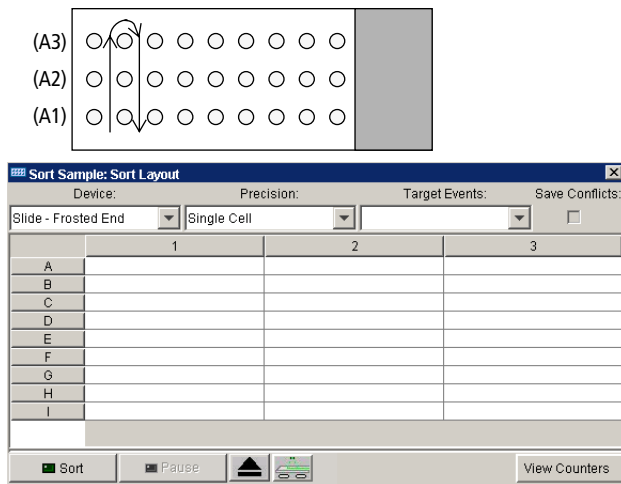

Figure 5-5 Sort order on a slide

Setting Up the Stream

This section describes how to optimize side stream deflection and how to adjust the Home location.

When sorting into a plate or onto a slide, the stage is preprogrammed to move a set interval between wells on a plate or spots on a slide. The Home location is used as the starting point: the far left stream should hit the center of the well in the top left corner of a plate or the top left corner of a slide at the Home location.

Default Home location coordinates exist for each standard sort collection device: Falcon multiwell plates with 6, 24, 48, 96, and 384 wells, and standard or frosted-end slides. For other plate types, you will need to set the Home location. See *Creating a Custom Device* on page 158.

Use the following procedure to verify the Home location and adjust it, if needed.

- 1 Optimize the drop delay.

See *Determining the Drop Delay* on page 145.

2 Turn on the deflection plates.

Click the Voltage control () in the Side Stream window. The voltage warning light illuminates, indicating that the plates are charged.

NOTICE Make sure the center stream image does not move after the plates are turned on. If the stream image is off-center, use the Voltage Center slider to re-center the stream. Major movement of the center stream could indicate that the plates or area around the plates needs cleaning. See External Cleaning on page 174.

3 Turn on Test Sort and optimize the far left side stream; turn off Test Sort.

Adjust the far left slider for minimal deflection of the stream. The stream should be deflected just enough to clear the hole in the splash shield. Do not adjust the other sliders.

If you cannot see a stream image or the image is dim, adjust the micrometer dial on the BD AccuDrop laser to better view the streams (Figure 1-17 on page 41).

4 Choose Sort > Home Device.

5 In the Device Setup dialog box, choose the collection device you are using and click Go to Home.

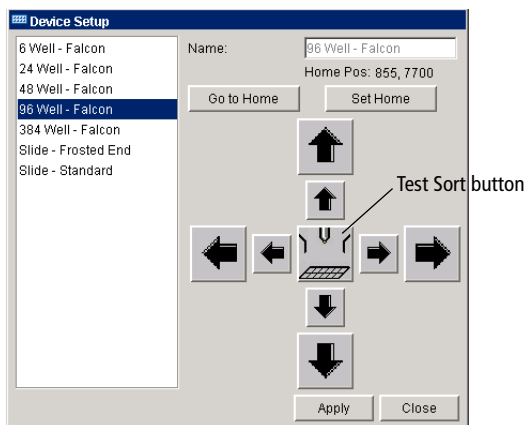

The stage moves to the preprogrammed Home position.

6 Double-click the Test Sort button to deposit a drop at the Home location.

7 Inspect the collection device to see where the drop was deposited.

If you need to move the stage to the front, close the Device Setup dialog box, and click the Access Stage control in the Sort Layout view.

8 Wipe the collection device dry, and place it back on the tray support.

If needed, click the Access Stage control to send the stage back and choose Sort > Home Position to access the Device Setup dialog again.

9 Adjust the Home location, if necessary.

Click the appropriate Arrow buttons to move the tray support as needed. Large arrows move the tray by five steps; small arrows move the tray by one step.

10 Repeat steps 6 through 9 until the drop is centered appropriately.

11 Click Set Home, then Close.

12 Click the Voltage control () to turn off the deflection plates.

13 Proceed with Sorting on page 149.

Creating a Custom Device

You can program the ACDU stage to sort into any grid configuration. Create a custom device by entering the number of rows and columns and setting the Home and Farthest locations. BD FACSDiVa software calculates the increment between rows and columns to determine the sort locations.

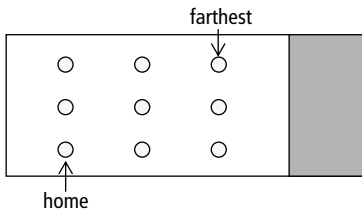
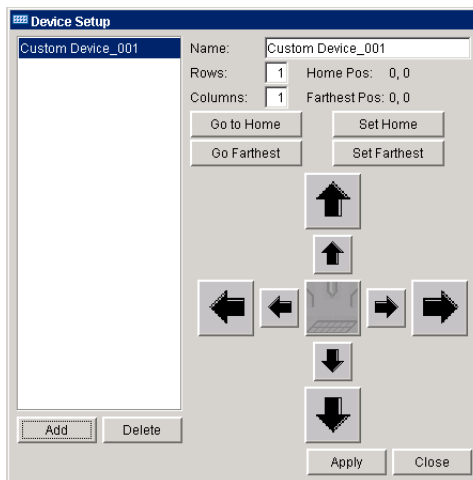

Figure 5-6 Home and Farthest location on 9-drop slide (example)

- 1 Choose Sort > Custom Devices.
- 2 Click the Add button in the Custom Devices dialog box.

A new device is added to the list of custom devices. By default, devices are named Custom Device_00x, where x is the next consecutively numbered device.



3 Select the text in the Name field and enter a new name.

4 Enter the number of sort location Rows and Columns.

A device can have up to 60 rows and 25 columns.

5 Use the Arrow keys and the Test Sort button to set the Home location; click Set Home.

See Setting Up the Stream on page 155 for details. There are no default values for custom devices, so greater initial adjustment with the Arrow keys is required.

6 Use the same procedure to set the Farthest location; click Set Farthest.

The Farthest sort location is the well or spot on the lower-right corner of the collection device.

7 Click Apply, then Close.

After you set the Home and Farthest locations, custom devices are listed in the Device drop-down menu in the Sort Layout view.

NOTICE Once custom devices are defined, you cannot change the number of rows and columns.

8 Click the Voltage control () to turn off the deflection plates.

9 Proceed with Determining the Drop Delay on page 145 and Sorting on page 149.

Deleting a Custom Device

- 1** Choose Sort > Custom Devices.
- 2** Select the name of the custom device to be deleted in the Custom Devices dialog box.
- 3** Click Delete.

The device is deleted from the Custom Device list, but is retained within any Sort Layouts where it was used.

6

DNA Analysis

The following topics are covered in this chapter:

- Criteria for DNA Experiments on page 162
- CEN Optimization on page 163
- CTN Resolution on page 168
- Running Test Samples on page 170

Criteria for DNA Experiments

In DNA experiments, the flow cytometer must provide the following:

- resolution
- linearity
- ability to distinguish singlets from aggregates

Obtaining good resolution for the DNA signal depends on proper sample preparation and instrument performance. The resolution of a flow cytometer can be assessed by measuring the CV of a reference particle: the lower the CV, the better the resolution.

Linearity is critical for DNA experiments. To verify the linearity of DNA data, the pulse-area signal is used to measure the amount of DNA fluorescence detected from cells and nuclei. For example, the G_2+M peak should be located at twice the mean channel of the G_0/G_1 peak (Figure 6-1).

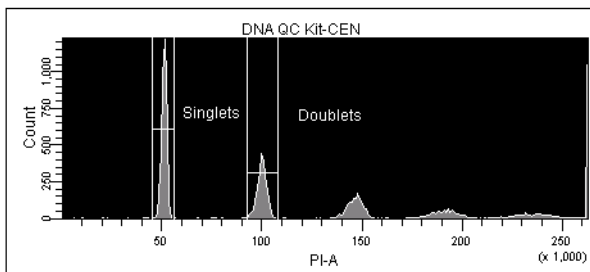

Figure 6-1 Area signal measures DNA fluorescence

Doublet discrimination, or the ability to resolve singlets from aggregates, is also important for DNA experiments. Aggregated cells or nuclei are detected as events that have two or more times the amount of singlet fluorescence. For cell-cycle analysis, it is important to resolve singlets from aggregates because doublets of G_0/G_1 cells have the same amount of DNA fluorescence as singlet G_2+M cells. Therefore, these doublets accumulate in the same fluorescence area channel as singlet G_2+M cells (Figure 6-2 on page 163).

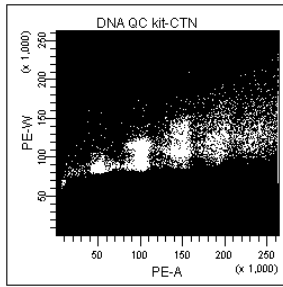

Figure 6-2 Doublet discrimination

Before beginning this chapter, do the following.

- Prepare biological standards for instrument quality control using the BD DNA QC Particles kit (Catalog No. 349523). Prepare one tube each of chicken erythrocyte nuclei (CEN) and calf thymocyte nuclei (CTN) sample according to the kit instructions.
 - The CEN sample is used for instrument optimization and to check instrument resolution (CV) and linearity.
 - The CTN sample is used to verify the system's ability to resolve singlets from aggregates.
- Start up the instrument as described in Starting Up the Instrument on page 100. Choose the High Sort Setup to run at 70 psi with the 70 μ m nozzle.
- Optimize the instrument electronics as described in Instrument Quality Control on page 105. Verify the laser Delay and Area Scaling at the required sheath pressure.

CEN Optimization

Use the following procedure to set up BD FACSDiVa software for a DNA experiment that uses propidium iodide (PI) as the DNA-staining dye (eg, the BD DNA QC Particles kit). You can also stain samples with DAPI or Hoechst, and detect signals from the violet laser. If you are using another sample type, modify the steps accordingly.

Setting Up the Experiment

The default Instrument Configurations list only the PE parameter. If required, you can use the Experiment Layout dialog box to label the PE parameter as PI, or you can create a new Instrument Configuration that lists the PI parameter. (See *Defining a New Configuration* on page 236 for instructions.) The steps in the following sections refer to the default PE parameter. If you have relabeled the parameter, adjust the steps accordingly.

NOTICE For accurate data results, the instrument optics setup must match the current Instrument Configuration.

1 Press Ctrl-E to create a new Experiment; rename the Experiment *DNA*.

Tip To place the Experiment inside an existing folder, select the folder before creating the Experiment.

2 Rename the new Specimen *DNA QC Kit* and rename the first Tube *CEN*.

This Tube will be used to optimize signals from the first laser. Your Experiment should look similar to that shown in the figure at the right.

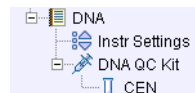

3 Click the Parameters tab in the Inspector and make the following changes:

- Select the Height (H) and Width (W) checkboxes for PE.
- Deselect the Log checkbox for all parameters.

Parameter	Voltage	Log	A	H	W
FSC	250	<input type="checkbox"/>	<input checked="" type="checkbox"/>	<input type="checkbox"/>	<input type="checkbox"/>
SSC	300	<input type="checkbox"/>	<input checked="" type="checkbox"/>	<input type="checkbox"/>	<input type="checkbox"/>
FITC	500	<input type="checkbox"/>	<input checked="" type="checkbox"/>	<input checked="" type="checkbox"/>	<input type="checkbox"/>
PE	500	<input type="checkbox"/>	<input checked="" type="checkbox"/>	<input checked="" type="checkbox"/>	<input checked="" type="checkbox"/>
PE-Texas Red	500	<input type="checkbox"/>	<input checked="" type="checkbox"/>	<input checked="" type="checkbox"/>	<input type="checkbox"/>

- Click the Threshold tab and change the threshold parameter to PE; verify that the threshold value is set to 5,000.

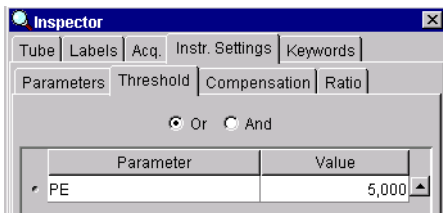

- Create the following plots for the DNA Tube:
 - FSC-A vs SSC-A dot plot
 - PE-A vs PE-W dot plot
 - PE-A histogram
- Create a Statistics view and display the mean and CV for PE-A.
 - Right-click the CEN Tube and choose Create Statistics View.
 - Right-click the Statistics view and choose Edit Statistics View.
 - On the Population tab, deselect # Events and %Parent.
 - On the Statistics tab, select the Mean and CV for PE-A.
 - Set Decimal Places to 1 for the CV.

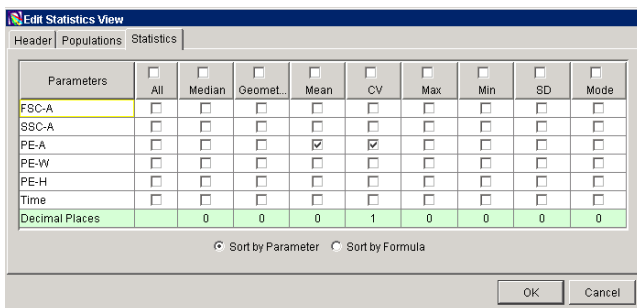

- 7 In the Acquisition Controls frame, set the Events to Record to 10,000 evt and the Events to Display to 500 evt.

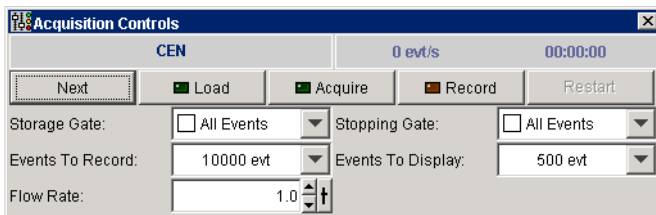

- Tip** Decreasing the number of displayed events will increase the data refresh rate.

Running CEN

- 1 Verify that the green Acquisition pointer is in front of the CEN Tube in the Browser.
- 2 Install the CEN sample tube onto the loading port; click Load in the Acquisition Controls frame.

Events appear in the plots.
- 3 Adjust the Flow Rate to the lowest possible value (1.0).
- 4 Adjust the FSC and SSC voltages to place the CEN on scale in the FSC vs SSC dot plot.

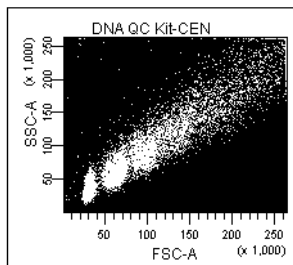

- 5 Adjust the PE voltage to place the singlet nuclei at approximately channel 50×10^3 on the PE-A axis in the histogram plot.
- 6 Click Record to save the data.
- 7 Draw an Interval gate around the first two peaks on the PE-A histogram; name the populations *Singlets* and *Doublets* (Figure 6-3).

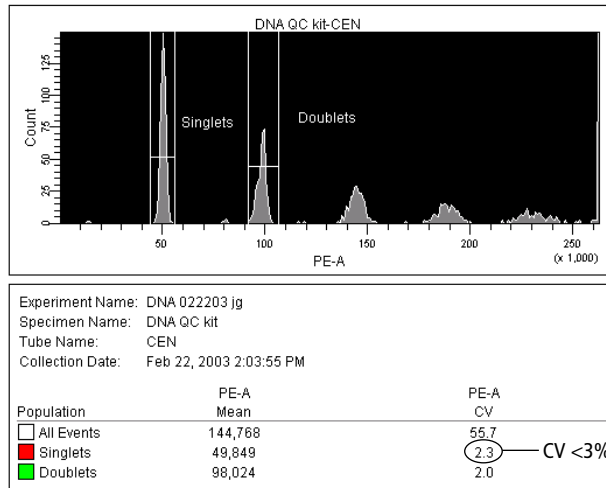

Figure 6-3 Defining Singlet and Doublet populations

- 8 Check the CV of the Singlet population.
If the CV is >3%, see Acquisition Troubleshooting on page 213 for high CVs.
- 9 Check the linearity and print the worksheet.
 - Note the means of the Singlet and Doublet populations. Divide the mean of the Doublets by the mean of the Singlets. The Doublet/Singlet ratio should be 2.00 +/-0.05.
 - Copy the means, CVs, and the calculated linearity result into the QC log.
- 10 Unload the CEN sample and remove the tube from the loading port.

CTN Resolution

Singlets can be distinguished from aggregates based on size. With BD FACSDiVa software, aggregates can be resolved from singlets on an Area vs Height plot in conjunction with an Area vs Width plot. On the Area vs Height plot singlets can be distinguished from doublets by their height on the y-axis; singlets have slightly more height. On the Area vs Width plot, singlets are distinguished from doublets by the Width measurement; singlets have a smaller Width measurement. Discriminating the singlets from the aggregates enhances the accuracy of cell-cycle analysis.

Running CTN

- 1 Click the Next button in the Acquisition Controls frame; change the name of the new Tube to *CTN*.

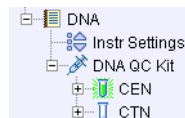

The Next button duplicates the CEN Tube and Analysis objects. The new plots and Statistics view appear below the previous objects on the worksheet.

- 2 Install the CTN sample tube onto the loading port; click Load.

Acquisition starts automatically and events appear in the plots.

- 3 Delete the Interval gates on the PE-A histogram.
- 4 Adjust the PE voltage to place the first peak at approximately channel 50×10^3 on the PE-A axis.

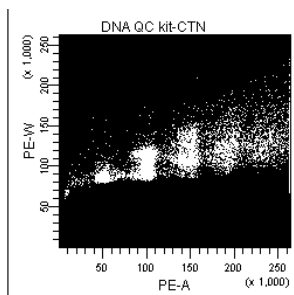

- 5 Click Record to save the data; print the worksheet.
- 6 Unload the CTN Tube and remove it from the cytometer.
- 7 (Optional) Use the Zoom-In tool to magnify the area showing the singlets and doublets on the PE-A vs PE-W plot.

Magnify the area from the left of the singlets to the right of the doublets, including only the area of interest. The zoomed-in area should be long and narrow.

- Tip** To better view the doublet discrimination, display the data in a contour plot.

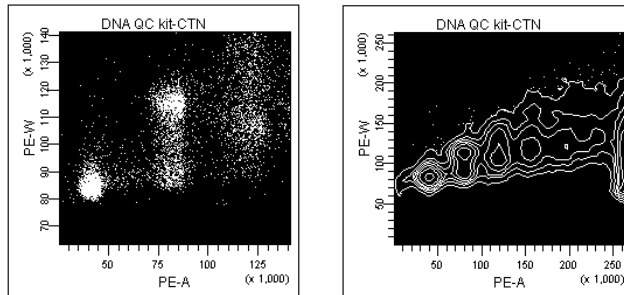
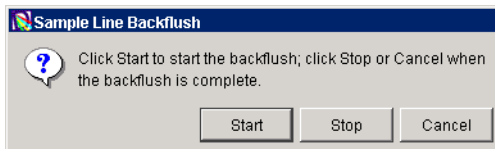

Figure 6-4 Doublet discrimination in zoomed-in plot (left) and contour plot (right)

- 8 (Optional) Draw a gate around the singlet CTN.
- 9 Backflush the sample line for at least 10 seconds to remove residual PI.
 - Choose Instrument > Cleaning Modes > Sample Line Backflush.
 - Click Start to start the backflush; click Stop or Cancel after 10–20 seconds. (The backflush does not stop automatically.)



Running Test Samples

Optimize the instrument settings for the actual sample.

- 1** Install the sample tube and optimize the FSC and SSC signals.
- 2** Optimize the PE (PI) voltage to place the singlets close to channel 50×10^3 .
- 3** Verify the doublet discrimination by zooming in on the PE-A vs PE-W plot.

After optimizing the instrument settings, record data for each sample tube. Export data files for analysis in a third-party application such as ModFit *LT*[™].

Shutdown and Maintenance

The BD FACSAria instrument is designed to require minimum maintenance. However, to preserve the reliability of the instrument, you must regularly perform basic preventive maintenance procedures. This chapter explains routine maintenance procedures you should follow to keep your instrument in good condition.

Maintenance procedures are presented as follows:

- Daily Shutdown on page 172
- Scheduled Maintenance on page 178
- Unscheduled Maintenance on page 198

Daily Shutdown

Run the following procedures at the end of each day or when required:

- Fluidics Shutdown on this page
- External Cleaning on page 174

Fluidics Shutdown

At the end of each day the instrument is used, run the Fluidics Shutdown procedure to remove sheath fluid from the sheath path and rinse all lines with DI water. This prevents saline crystals from clogging the fluidics.

NOTICE Allow approximately 3 minutes to complete the shutdown procedure.

- 1 Unload your sample tube, if one is loaded.
- 2 Turn off the lasers.
- 3 Turn off the stream.
- 4 Choose Instrument > Fluidics Shutdown.

The following message appears.

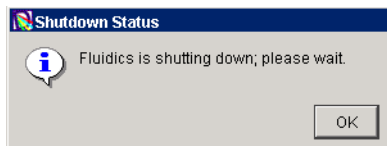

- 5 (Optional) Click OK to dismiss the message.
- 6 Empty the waste and refill the DI water, if prompted to do so.

See Setting Up the Fluidics Cart on page 102. If you disconnect the DI water tank for refilling, prime the system before continuing.

The instrument starts the Daily Clean cycle. Daily Clean removes sheath from the lines and plenum and replaces it with DI water.

- 7 When prompted, install a tube containing approximately 3 mL of cleaning fluid such as BD FACSRinse solution (BD Catalog No. 340346), and click OK.

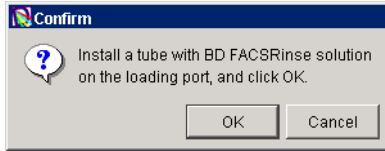

The instrument loads the tube and cleans the cuvette with the cleaning solution. A progress message appears during the cleaning process; click OK to dismiss the message, if you would like.

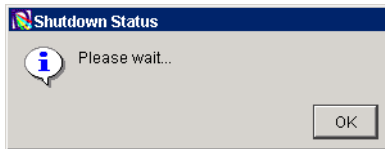

- 8 When prompted, install a tube containing approximately 3 mL of DI water; click OK.

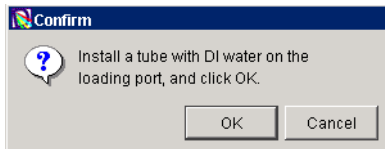

The instrument loads the tube and rinses the cuvette with DI water. A progress message appears during the cleaning process; click OK to dismiss the message, if you would like.

- 9 Click OK when you see a message informing you that the system can be turned off.

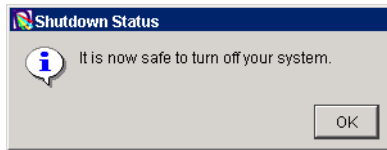

- 10 Turn off the instrument main power; quit BD FACSDiVa software and shut down the computer.

External Cleaning

To keep the system free from salt buildup, wipe down all instrument surfaces that have been exposed to sheath fluid. Clean surfaces with a cloth dampened with a 10% bleach solution, followed by DI water.

⚠ WARNING All instrument surfaces that come in contact with biological specimens can transmit potentially fatal disease. Use universal precautions when cleaning instrument surfaces. Wear suitable protective clothing and gloves.

⚠ WARNING To prevent shock, turn off the plate voltage before cleaning on or around the deflection plates. To prevent arcing (sparking), make sure the plates are completely dry before you turn the plate voltage back on.

The following surfaces should be inspected and cleaned when necessary:

- inside the sort block
- deflection plates
- grounding plate (see the following section)

Cleaning the Nozzle and Grounding Plate

If sheath fluids leaks or sprays onto the grounding plate within the cuvette flow cell, you will need to remove the plate and clean and dry it thoroughly before you continue operating the instrument. Perform this procedure when you observe no deflection or insufficient deflection during sorting, or anytime the nozzle gets wet.

⚠ WARNING Any instrument surface that comes in contact with biological specimens can transmit potentially fatal disease. Use universal precautions when handling sorting hardware. Wear suitable protective clothing and gloves.

- 1 Turn off the deflection plate voltage; turn off the lasers and stream.
 - 2 Open the sort block door and remove the grounding plate under the nozzle.
- Tip** Use the wooden end of a cotton swab to pull the grounding plate toward you.

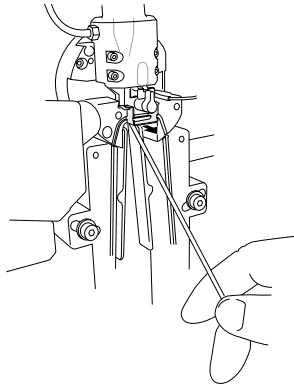

- 3 Pull the stream-charging wire out of the nozzle.

See Figure 7-1 on page 176.

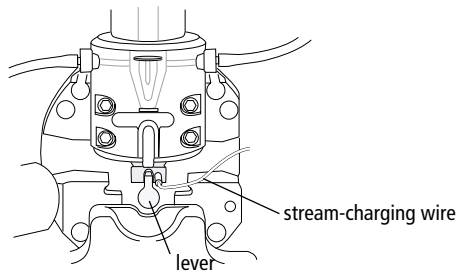

Figure 7-1 Removing the stream-charging wire

- 4 Turn the nozzle-locking lever to the left, and pull the nozzle out of the cuvette flow cell.

Tip To avoid losing the O-ring, hold the nozzle steady and pull it straight out without tilting it from side to side. If you do not see the O-ring on the nozzle, it could be stuck to the cuvette. Use the wooden end of a cotton swab to locate and remove the O-ring.

- 5 Turn the nozzle-locking lever 180° to the right; while holding your left index finger along the left side of the lever, pull out the lever.

NOTICE There is a compressed spring at the end of the lever. Keep your finger alongside the lever to prevent the spring from shooting out when it is released. If you lose the spring or plunger, spare parts are included in the accessory kit.

- 6 Remove the spring and plunger from the end of the lever (Figure 7-2).

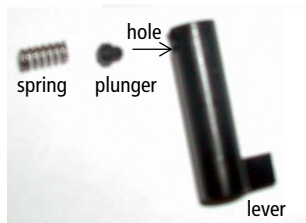
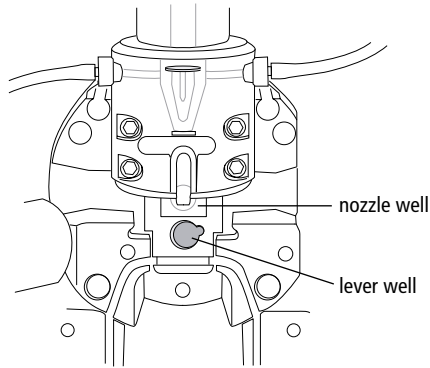

Figure 7-2 Disassembling the lever

- 7 Clean the disassembled parts and the exposed instrument surfaces with DI water.

Clean the nozzle, grounding plate, lever, spring, and plunger, along with the hole in the end of the lever, the lever well, and the nozzle well.



- 8 Thoroughly dry the disassembled parts and the exposed instrument surfaces with a Kimwipe or a cotton swab.

NOTICE If you use a swab, make sure no cotton fibers are left behind.

- 9 Reassemble and reinstall the nozzle-locking lever.

Insert the small end of the plunger, and then the spring into the lever hole as shown in Figure 7-2.

Install the lever at an angle to compress the spring against the side of the lever well. Once the spring is fully compressed, straighten out the lever and push it all the way to the back. Turn the lever 180° to the left to lock the lever in place.

- 10 Reinstall the grounding plate and the nozzle.

NOTICE Install the grounding plate with the notched end *toward* you.

Make sure an O-ring is installed inside the groove at the end of the nozzle. Insert the nozzle at a slight

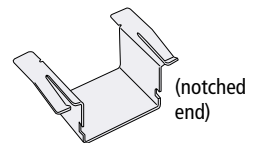

downward angle to avoid contact between the O-ring and the cuvette. Push it gently all the way forward without rocking it from side to side.

- 11 Turn the nozzle-locking lever clockwise to the 12:00 position, and plug the stream-charging wire into the nozzle.
- 12 Restart the stream and verify it runs smoothly through the grounding plate.

If you need further assistance, see *Troubleshooting the Stream* on page 204.

Scheduled Maintenance

For optimal instrument functioning, perform the following procedures according to the recommended maintenance schedule.

Procedure	Recommended Frequency
Internal Cleaning on page 178	See Table 7-1 on page 179
Purging Filters on page 192	Weekly
Changing Fluid Filters on page 193	Every 3–6 months
Changing the Sample Lines on page 194	Every 4–6 months, or when required
Changing Air Filters on page 197	Every 6–12 months, depending on instrument use and the quality of the air

Internal Cleaning

BD FACSDiVa software includes four pre-programmed cleaning modes that can be used singly or in combination to provide the required level of cleaning.

The following sections describe what actions are taken when you choose the indicated command from the *Instrument > Cleaning Modes* menu. See Table 7-1 on page 179 for an overview of each mode.

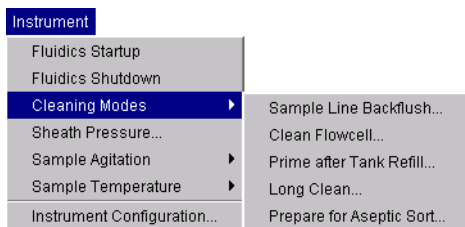

Table 7-1 Instrument cleaning modes

Cleaning Mode	Summary	Frequency
Sample Line Backflush on page 180	Flushes the sample line with sheath fluid	After running samples with adherent cells or dye
Clean Flowcell on page 181	Cleans the sample path and the flow cell with a decontaminant	When indicated by distorted scatter, high CVs
Prime After Tank Refill on page 182	Primes the fluid lines for the designated fluid(s)	When a fluidics line is unplugged to refill a tank
Long Clean on page 183	Decontaminates the internal sheath path with bleach or ethanol and rinses it with DI water	Monthly
Clean Bulk Injection Chamber on page 186	Decontaminates the sample injection chamber with ethanol	Monthly
Prepare for Aseptic Sort on page 188	Decontaminates the complete sheath path with ethanol and rinses it with DI water	When needed before aseptic sorting

⚠ NOTICE Some of the internal cleaning modes require that you turn off the stream. Remember to always turn off the lasers before you turn off the stream. Running the lasers without the stream can degrade the performance of the cuvette flow cell.

Sample Line Backflush

After a sample tube is unloaded, the sample line tubing within the sample injection chamber is automatically flushed inside and out with sheath fluid to eliminate potential sample carryover. Use the Sample Line Backflush command to perform additional backflushing of the inside of the sample line after a tube unloads. Perform the Sample Line Backflush when you observe sample carryover or after running samples with adherent cells or dye.

NOTICE Keep the stream running while performing the backflush.

- 1 Choose Instrument > Cleaning Modes > Sample Line Backflush.
- 2 Click Start to start the backflush.

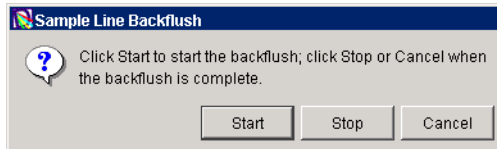

- 3 Click Stop to stop the backflush, or click Cancel to stop the backflush and close the dialog box.

NOTICE The backflush does not stop automatically.

Clean Flowcell

Use the Clean Flowcell command to run a tube of cleaning fluid such as BD FACSRinse solution (BD Catalog No. 340346) through the sample line and flow cell, without sheath running. After the procedure is complete, the cleaning fluid remains in the sample line and flow cell until the stream is restarted.

Note that the Clean Flowcell procedure is run automatically during fluidics shutdown. You can repeat the procedure when poor optical performance indicates that additional cleaning is needed.

- 1 Turn off the lasers and the stream, if they are on.
- 2 Choose Instrument > Cleaning Modes > Clean Flowcell.
- 3 When prompted, install a tube containing approximately 3 mL of cleaning fluid (such as BD FACSRinse solution), and click OK.

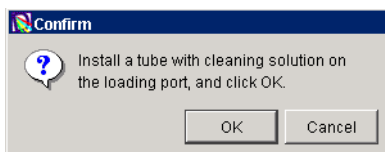

The instrument loads the tube and cleans the cuvette with the cleaning solution. A progress message appears during the cleaning process; click OK to dismiss the message, if you would like.

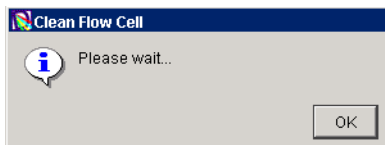

- 4 Click OK when the completion message appears.
- 5 Wait a few minutes and then restart the stream and lasers.

Prime After Tank Refill

Use the Prime After Tank Refill command to prime the fluid lines if a fluidics container was disconnected for refilling.

- 1 Turn off the lasers and the stream, if they are on.
- 2 Choose Instrument > Cleaning Modes > Prime After Tank Refill.
- 3 Select the checkboxes for the tanks that were refilled; click OK.

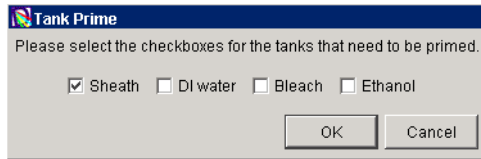

The instrument proceeds with priming the specified tanks. The bleach and ethanol tanks are primed before the DI tank is primed. A progress message appears while the tanks are being primed; click OK to dismiss the message, if you would like.

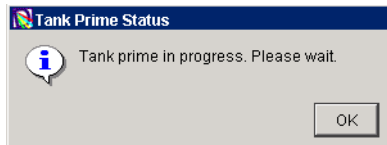

- 4 Click OK when you see a message informing you that the tank prime is complete.

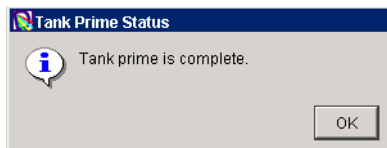

Long Clean

Use the Long Clean command to decontaminate the internal sheath path with bleach or ethanol, from the fluid line starting at the outlet of the fluid selection valves in the fluidics cart, to the nozzle outlet. After decontamination, the lines are rinsed with DI water.

There are three Long Clean options: Long Clean with Bleach, Long Clean with Ethanol, and Clean Bulk Injection Chamber. Use the Bleach option to remove adhesive dyes such as PI, acridine orange, or thiazole orange, or when you want to decontaminate the sample lines. Use the Ethanol option to decontaminate the lines using ethanol. The Clean Bulk Injection Chamber option is described on page 186.

 **WARNING** All biological specimens and materials coming into contact with them can transmit potentially fatal disease. Use 10% bleach to decontaminate the sheath path. Flushing the lines with 10% bleach is the only procedure recommended by BD Biosciences for decontaminating the instrument.

NOTICE This procedure can take 10–40 minutes, depending on how long you run the stream to remove trace decontaminant.

- 1** Ensure fluid levels are adequate; empty the waste container if it is full.

For example, if you are performing a bleach cleaning procedure, make sure the bleach tank is full. The long clean requires approximately 90 mL of cleaning fluid and 110 mL of DI water.

- 2** Turn off the lasers and the stream, if they are on.
- 3** Choose Instrument > Cleaning Modes > Long Clean.

If you have not already turned off the stream, a message appears reminding you to do so.

- 4** Select a Long Clean option; click OK.

Choose from the following:

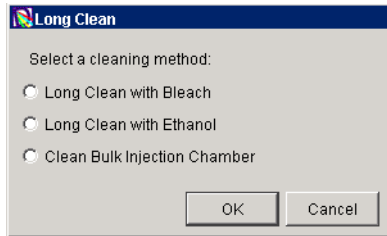

NOTICE For the bulk injection chamber option, see Clean Bulk Injection Chamber on page 186.

- 5 Wait 8–10 minutes for the cleaning cycle to finish; click OK to dismiss the completion message.

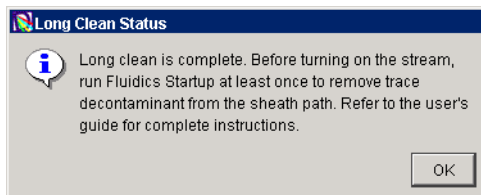

NOTICE If the completion message does not appear after 10 minutes, verify that there are no error messages in the Status tab of the Instrument frame. If the cleaning mode fails, see Fluidics Cart Troubleshooting on page 219.

- 6 (Optional) Remove the plenum reservoirs and wipe them down with bleach or ethanol, followed by DI water.

BD Biosciences recommends that you remove the plenum reservoirs only for the most stringent decontamination. You do not need to perform this step each time you run a Long Clean.

If needed, see Cleaning the Plenum Reservoirs on page 185.

- 7 Choose Instrument > Fluidics Startup.

The Fluidics Startup procedure removes cleaning fluid from the plenum tanks and fluid lines and replaces it with sheath fluid.

The following steps are not required, but are recommended for removing residual decontaminant after performing a Long Clean with bleach or ethanol. This will ensure a safe environment for biological samples.

- 8** When startup is complete, choose Instrument > Fluidics Shutdown.
- 9** When shutdown is complete, choose Instrument > Fluidics Startup again.
- 10** (Optional) When the startup is complete, turn on the stream and let it run for 20–30 minutes.

Cleaning the Plenum Reservoirs

After you run a Long Clean with bleach or ethanol, you can clean the plenum reservoirs by autoclaving them or by wiping them down with ethanol or DI water. Use the following procedure to remove and clean the reservoirs.

- 1** Turn off the instrument main power.
- 2** Open the side door and verify that the plenum reservoirs are empty.
- 3** Place absorbent paper under the plenum reservoirs and remove each reservoir by unscrewing it from its receiver.

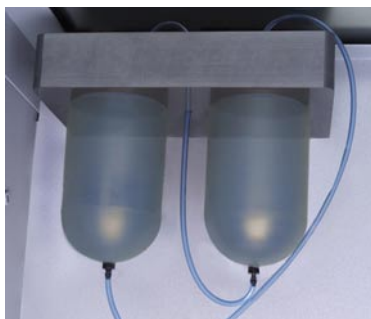

Figure 7-3 Plenum reservoir

- 4 Pull off the tubing connected to each reservoir tank.
- 5 Autoclave the reservoirs or wipe them down with 70% ethanol, followed by DI water.

After wiping them down, dry them with a clean, lint-free cloth.

- 6 Clean the float and reservoir receiver for each plenum tank.

Use a spray bottle to clean the floats; use a cloth soaked with ethanol to wipe down the receivers.

⚠ NOTICE The floats are fragile. Handle them with care. Do not spray ethanol into the instrument behind or below the plenum reservoirs.

Dry each float and reservoir with a clean, lint-free cloth.

- 7 Reinstall the plenum reservoirs.

Screw each reservoir to its receiver, while making sure that the O-rings are seated properly within each plenum tank. Reattach the tubing to the bottom of each reservoir.

Clean Bulk Injection Chamber

Use the Clean Bulk Injection Chamber option to flush the injection chamber with DI water and ethanol.

NOTICE Allow 5–10 minutes to complete the cleaning procedure.

- 1 Ensure fluid levels are adequate; empty the waste container if it is full.

This procedure requires approximately 250 mL each of DI water and ethanol.

- 2 Turn off the lasers and the stream, if they are on.
- 3 Remove the tube holder from the loading port.

It can be cleaned separately by wiping it down with ethanol, if needed.

4 Choose Instrument > Cleaning Modes > Long Clean.

If you have not already turned off the stream, a message appears reminding you to do so.

5 Select the Clean Bulk Injection Chamber option; click OK.

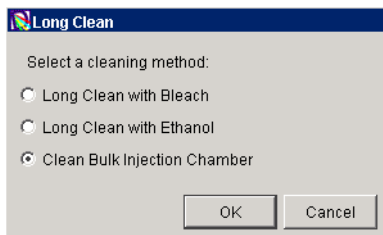

During the next 4–5 minutes, the instrument performs the following:

- closes and seals the bulk injection chamber
- fills the chamber with DI water, and flushes the chamber
- fills the chamber with ethanol, and flushes the chamber
- air-dries the chamber, and then opens it

A message appears when cleaning is complete.

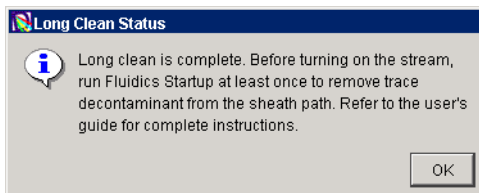

6 Click OK to dismiss the completion message.

7 Use a clean, dry cloth to remove residual ethyl alcohol from the loading port.

8 Before using the system, choose Instrument > Fluidics Startup.

Prepare for Aseptic Sort

Use the Prepare for Aseptic Sort command when you want to decontaminate the entire sheath path with ethanol, from the fluid line starting at the sheath inlet port in the fluidics cart, to the nozzle outlet. For the most complete decontamination, autoclave the sheath container and sheath probe and install a new sheath filter before sorting.

Note that the plenum reservoirs can also be removed and autoclaved or cleaned with ethanol before running this cleaning mode, if required. To do so, run a Long Clean with bleach or ethanol as described in Long Clean on page 183, and then clean the plenum reservoirs as described on page 185.

NOTICE This procedure can take 10–40 minutes, depending on how long you run the stream to remove trace decontaminant.

Cleaning the Lines with Ethanol

- 1 Ensure fluid levels are adequate; empty the waste container if it is full.

This procedure requires approximately 250 mL of ethanol.

- 2 Turn off the lasers and the stream, if they are on.
- 3 Choose Instrument > Cleaning Modes > Prepare for Aseptic Sort.

A dialog box appears with instructions on how to set up for cleaning.

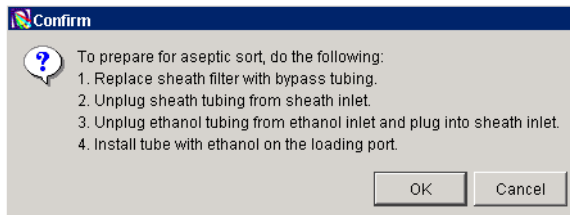

- 4 Remove the sheath filter by pressing the tabs on each quick-disconnect coupling.

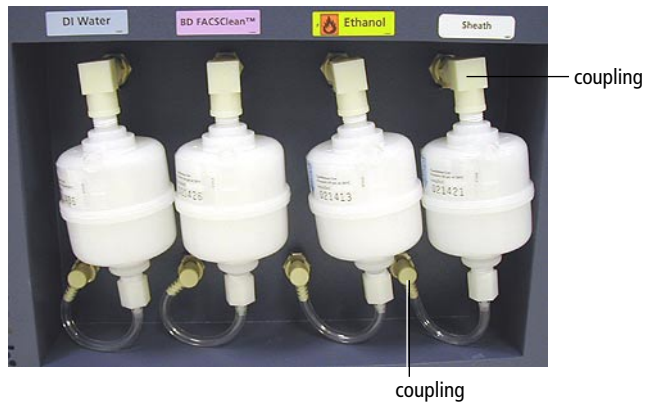

- 5 Install bypass tubing in place of the sheath filter.

Push the tubing coupling into each quick-disconnect port until you hear a click.

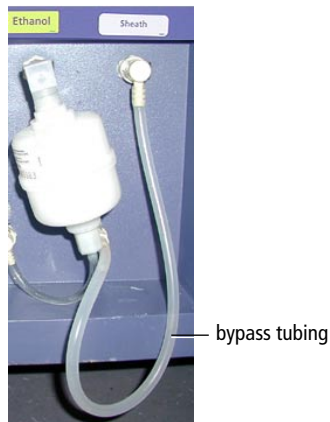

- 6 Detach the sheath tank tubing and the ethanol tubing from their respective ports on the fluidics cart (Figure 7-4 on page 190).

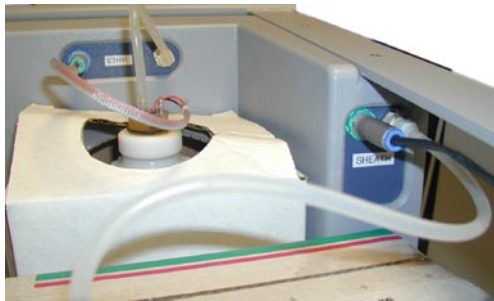

Figure 7-4 Sheath and ethanol ports

- 7** Plug the ethanol tank quick-disconnect into the Sheath port.
- 8** Install a tube containing ethanol onto the loading port; click OK.

A progress message appears. During the next 3–5 minutes, the instrument performs the following:

- primes all fluid lines with ethanol
- turns on the stream
- loads the ethanol tube and starts running it

Once the instrument is running ethanol through all lines, a message appears.

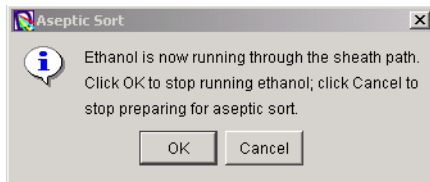

- 9** Let the ethanol run as long as you like; **click OK** when finished.

NOTICE Click Cancel only if you want to cancel the cleaning mode. Do not click Cancel to stop running ethanol.

The instrument stops running the ethanol sample, unloads the tube, and stops the stream.

Replacing the Ethanol with Sheath Fluid

Now that all fluid lines have been cleaned, the system prompts you to install an autoclaved sheath container on the fluidic cart. Follow these steps to complete the cleaning procedure.

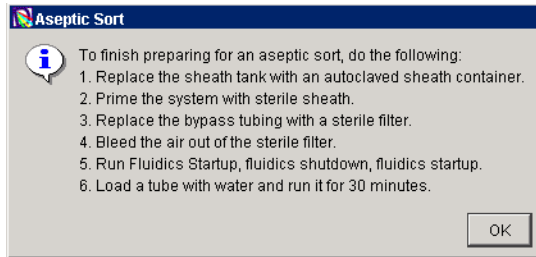

- 1 At the prompt, detach the ethanol line from the Sheath port on the fluidics cart and connect it to the Ethanol port (Figure 7-4 on page 190).
 - 2 Connect an autoclaved sheath container to the Sheath port.
 - Tip** To prevent contamination, autoclave the sheath probe and tubing along with the container. Fill the container with sterile sheath fluid.
 - 3 Prime the system with sterile sheath fluid.
 - Click OK to dismiss the instruction message, and choose Instrument > Cleaning Modes > Prime After Tank Refill.
 - Select the Sheath checkbox; click OK.
 - 4 When the prime is finished, remove the bypass tubing and install a new sheath filter in its place.
 - 5 Open the bleeder valve on top of the filter and wait for fluid to seep out of the bleeder valve; close the valve.
- See Purging Filters on page 192.

6 Choose Instrument > Fluidics Startup.

For additional decontamination, run the Fluidics Shutdown procedure when the system is ready and then repeat the Fluidics Startup procedure again.

7 Install a tube of DI water on the loading port; load the tube and run it for 10 minutes.

8 (Optional) Run the stream for an additional 10–20 minutes.

Purging Filters

Once a week, purge air from all fluid filters by opening the bleeder valve on the top of each filter in turn. This ensures that the filters will not dry out.

1 Unscrew the bleeder valve on the top of the filter.



2 Wait until fluid seeps out through the valve.

3 Close the valve.

Changing Fluid Filters

BD Biosciences recommends changing the fluid filters every 3–6 months, or when increased debris in an FSC vs SSC plot indicate that the sheath filter needs to be replaced. Spare filters are included with the accessory kit.



- 1 Remove the filter by pressing the tabs on each quick-disconnect coupling.
- 2 Install the new filter and connect the quick-disconnect couplings.
- Tip** Write today's date on the filter so you will know when to replace it.
- 3 Open the bleeder valve on top of the filter and leave it open until fluid seeps out through the valve.
- 4 Close the valve.

Changing the Sample Lines

The primary sample line between the sample injection chamber and the HPLC valve should be changed every 4–6 months or when decreased event rates indicate that the sample line might be clogged. The secondary sample line between the HPLC valve and the cuvette flow cell needs changing only when it is kinked or clogged.

To withstand the high pressures generated by the BD FACSAria flow cytometer, the sample lines are attached at each end using a two-piece compression fitting, where a cone-shaped ferrule is compressed onto the tubing as the connecting nut is tightened.

To replace the tubing, you will need a length of replacement tubing from the accessory kit. The 12-in. length of tubing is used for the primary sample line; the 7-in. length is used for the secondary line (Figure 7-5). The ferrules and connecting nuts can be reused when the tubing is replaced.

WARNING All biological specimens and materials coming into contact with them can transmit potentially fatal disease. Handle used tubing and fittings as if capable of transmitting infection. Wear suitable protective clothing and gloves.

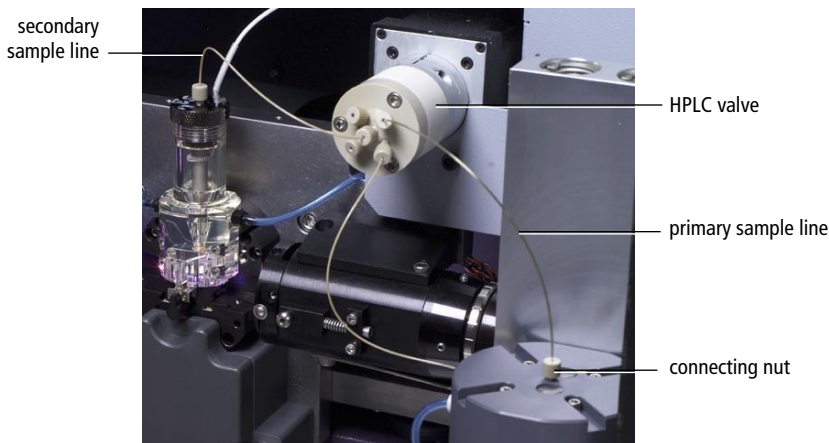
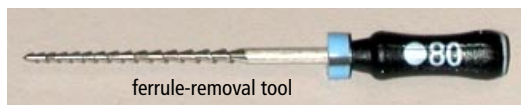

Figure 7-5 Sample line and HPLC valve

Use the following steps to replace the tubing. The same procedure can be used to replace either the primary or secondary sample line.

- 1 Turn off the stream and lasers(if needed); make sure the sample injection chamber is in the unload position.
- 2 Unscrew the connecting nuts on each end of the tubing and pull out the sample line.
- 3 Ensure that a cone-shaped ferrule is attached to each end of the sample line.

If the ferrule was left behind in the injection chamber fitting, the HPLC valve, or the flow cell fitting, use the ferrule-removal tool (included in the accessory kit) to locate and remove the ferrule.



- 4 Slide the ferrule and nut off each end of the sample line.
- Tip** Handle the ferrule with care; it is small and easily lost.
- 5 Slide the nut and then the ferrule onto each end of the new sample tubing.
 - If you are replacing the primary sample line, leave approximately 0.1 in. (0.25 cm) of tubing extending out of the ferrule on the HPLC end, and approximately 5 in. (12.7 cm) of tubing extending out of the sample injection chamber end. (This length can be adjusted depending on the depth of your sample tube.)
 - If you are replacing the secondary sample line, leave approximately 0.1 in. (0.25 cm) of tubing extending out of the ferrule on both ends.

This length is referred to as the pilot, as shown in Figure 7-6 on page 196.

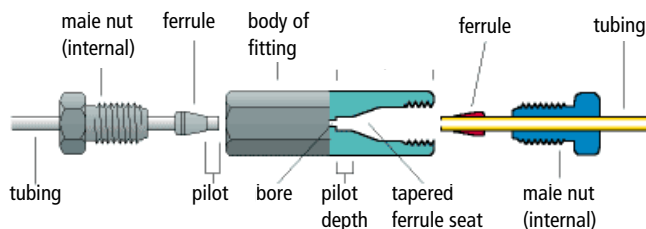

Figure 7-6 Components of a compression fitting (diagram courtesy of Valco Instruments Co. Inc.)

- 6 Insert the pilot tubing into its fittings, ensuring that the tubing reaches the intended pilot depths.

⚠ NOTICE Try not to bend the primary sample line during insertion.

- For the primary sample line, insert the long end into the sample injection chamber fitting. Push the tubing from the top until it is slightly above the bottom of the chamber viewing window. Hand-tighten the nut on top of the chamber, and then insert the short end into the HPLC valve.
- For the secondary sample line, insert one end into the HPLC valve, and the other end into the cuvette flow cell fitting.

⚠ NOTICE Within the HPLC valve and the cuvette flow cell fitting, make sure the pilot is seated flush against the pilot depth. Dead volume between the pilot and the pilot depth can lead to sample carryover or leaking.

- 7 Hand-tighten each nut firmly.

NOTICE Do not overtighten the nut and do not use tools. Over-tightening the nut can kink or damage the tubing so it would have to be replaced again.

- 8 Check the fitting connections to make sure they are not leaking.

Turn on the stream, load a tube of water, and make sure none of the fittings are leaking. If needed, unload the tube, turn off the stream, and tighten the fittings.

 **WARNING** Make sure all compression fittings are securely tightened. If any fitting is loose, the tubing could detach during high-pressure operation, exposing the operator to potentially biohazardous sample spray.

9 Verify the length of the sample line.

The sample line should not bow or bend when a tube is loaded. If you need to adjust the length, unscrew the nut on top of the sample injection chamber, adjust the length, and tighten the nut again.

Changing Air Filters

The BD FACSAria instrument has two air filters: one in the sort collection chamber door and one in the side door.

- To change the filter in the sort collection chamber door, slide out the old filter and slide in the new filter. Refer to the documentation provided with the Aerosol Management Option for more information.
- To change the air filter in the side door, turn the pegs at each corner of the filter and remove the old filter. Install a new filter and turn the pegs to hold the filter in place. Replace the filter annually to semi-annually, depending on the quality of the air in the laboratory.

Unscheduled Maintenance

There are several instrument components that should be cleaned periodically or checked for wear and replaced if necessary. See the indicated sections for the following maintenance procedures.

Procedure	Recommended Frequency
Cleaning a Nozzle on page 198	When stream irregularities indicate the nozzle is clogged
Cleaning the Camera Windows on page 200	When smudges appear in the Breakoff or Side Stream windows
Cleaning Optical Filters on page 202	As needed when changing a filter

Cleaning a Nozzle

Use one of the following methods to clean the nozzle when the stream appears blocked or distorted. To verify that the nozzle is clogged, examine the tip under a microscope. Figure 7-7 shows an example of an unclogged nozzle tip.

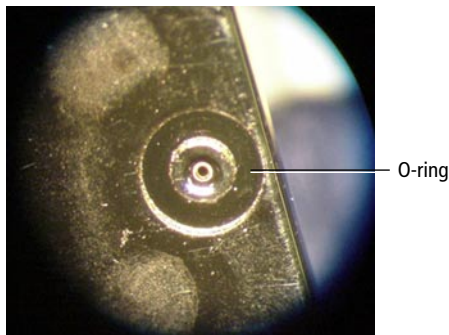

Figure 7-7 Magnified view of a nozzle tip

⚠ WARNING All biological specimens and materials coming into contact with them can transmit potentially fatal disease. Handle nozzles as if capable of transmitting infection. Wear suitable protective clothing and gloves.

1 Turn off the stream and lasers, if they are on.

2 Remove the nozzle from the cuvette flow cell.

Pull out the stream-charging wire and turn the nozzle-locking lever 90° to the left. Remove the nozzle by pulling it straight out.

3 Remove and set aside the O-ring.

4 Sonicate the nozzle for approximately 1 minute.

Sonicate the nozzle in a test tube containing DI water or a mild detergent. Repeat the sonication as needed until the nozzle is clean.

5 Use the wooden end of a swab to reinstall the O-ring on the nozzle tip.

6 Carefully reinsert the nozzle into the flow cell.

Insert it at a slight downward angle to avoid contact between the O-ring and the cuvette. Push it gently all the way forward without rocking it from side to side.

Turn the nozzle-locking lever clockwise to the 12:00 position, and plug the stream-charging wire into the nozzle.

7 Turn on the stream and make sure it flows through the nozzle properly.

8 Turn on the lasers.

Note that after reinstalling the nozzle, you might need to change the angle of the sort block to re-center the stream in the aspirator. To do so, loosen the adjustment screws on either side of the deflection plates and rotate the sort block (see Figure 1-11 on page 32). Tighten the screws when the stream is centered in the aspirator. For further assistance, see Troubleshooting the Stream on page 204.

Cleaning the Camera Windows

- Clean the lower camera window and the diode laser window when you have trouble viewing the side streams or you cannot set the drop delay using BD AccuDrop. Wipe the windows with a soft, lint-free cloth soaked with DI water, and then dry the windows.

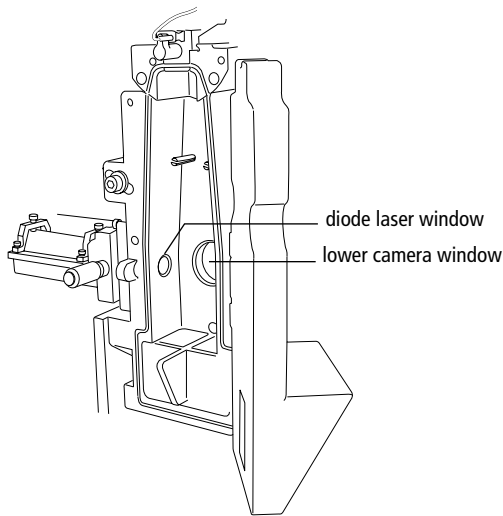

- Clean the strobe lens and upper camera window when smudges appear in the processed (digitized) image in the Breakoff window, or when dark spots appear to interfere with Sweet Spot monitoring. You might need to clean these components after a clog, or after sheath fluid has leaked or sprayed onto the grounding plate. Follow the steps in this section to clean the strobe lens and upper camera window.

NOTICE Before beginning this procedure, turn off the stream and lasers and ensure that the deflection plates are not charged (warning light is not illuminated).

⚠ WARNING A 12,000-volt potential exists between the deflection plates when they are on. Contact with the charged plates results in serious electrical shock. Do not touch the deflection plates when the plate voltage is on. The plates remain energized even when the sort block door is opened.

- 1** Open the sort block door and remove the deflection plates.

Pull the plates straight out to remove them.

- 2** Remove the nozzle and grounding plate.

For detailed instructions, see *Cleaning the Nozzle and Grounding Plate* on page 175. (You do not need to remove the lever.)

- 3** Place 1–2 drops of DI water or ethanol on a cotton swab.

- 4** Right-click the Breakoff window and choose Raw Image.

Visible smudges are more apparent in the raw image view.

- 5** While viewing the image on the Breakoff window, insert the swab just below the bottom of the cuvette.

The strobe lens and upper camera window are located behind two circular openings on either side of the cuvette. You will see the end of the swab in the Breakoff window when you intercept either opening.

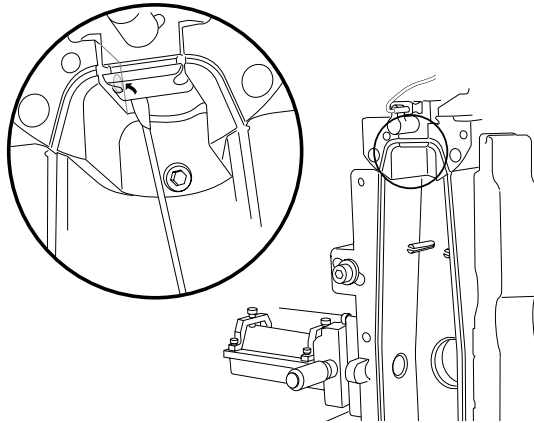

- 6** Gently wipe the strobe lens, and then the upper camera window to remove any saline.

- 7** Repeat with spectral-grade methanol or absolute ethanol until clean.

- 8 Reinstall the grounding plate, nozzle, and deflection plates.

See *Cleaning the Nozzle and Grounding Plate* on page 175 for details.

- 9 Adjust the plates so there is a gap of approximately 0.28 in. (0.7 cm) between them at the top.

Cleaning Optical Filters

Optical filters should be inspected occasionally and cleaned as necessary. The frequency will depend on how often the filters are handled.

NOTICE When cleaning or replacing a filter, handle with care to avoid scratching the surface and to prevent the filter from falling out of the holder. Use Q-tips, optical lens paper, and spectral-grade methanol or absolute ethanol in a dropper bottle (do not use acetone) to clean optical filters.

- 1 Wrap a triangular section of the lens paper around the cotton end of a Q-tip. Moisten and seal the end with a few drops of alcohol.
- 2 Holding the Q-tip in a horizontal position, gently rub any spots on the filter surface and wipe clean.
- 3 Allow the solvent to evaporate, and check the filter surface for streaks.
- 4 Inspect a quarter-inch-diameter section in the center of the filter for scratches.

Filters are coated with different dielectrics that can get scratched. If you see scratches, replace the filter.

- 5 Insert the cleaned filter into the octagon or trigon.

Make sure the filters are pushed all the way in.

Troubleshooting

The tips in this section are designed to help you troubleshoot your experiments. Additional troubleshooting information can be found in the *BD FACSDiVa Software User's Guide*.

If additional assistance is required, contact your local BD Biosciences technical support representative. See Technical Assistance on page xi.

Troubleshooting suggestions in this chapter are grouped under the following headings:

- Troubleshooting the Stream on page 204
- Troubleshooting the Breakoff on page 208
- Sorting Troubleshooting on page 209
- Acquisition Troubleshooting on page 213
- Fluidics Cart Troubleshooting on page 219
- Electronics Troubleshooting on page 220

Troubleshooting the Stream

Observation	Possible Causes	Recommended Solutions
Stream not in center of aspirator	Difference in keyed stream position between nozzles	If you have just changed the nozzle, use an Allen wrench to loosen the screws on either side of the sort block. Adjust the angle of the sort block until the stream flows into the center of the waste aspirator, and then tighten the screws. See Figure 1-11 on page 32.
	Nozzle inserted improperly	Turn off the stream. Remove the nozzle and ensure that the O-ring is in place. Reinsert the nozzle at a slight downward angle to prevent loss or movement of the O-ring. Make sure the nozzle is completely seated against the back wall of the cuvette flow cell.
	Clogged or damaged nozzle	Turn off the stream, remove the nozzle, and examine the nozzle tip under a microscope. <ul style="list-style-type: none">• If debris is visible, clean the nozzle. See <i>Cleaning a Nozzle</i> on page 198.• If the nozzle appears damaged, replace it. See <i>Changing the Nozzle</i> on page 140.

Troubleshooting the Stream (continued)

Observation	Possible Causes	Recommended Solutions
No stream or dripping stream	Grounding plate inserted improperly	Make sure the grounding plate is inserted with the notched end toward you. See <i>Cleaning the Nozzle and Grounding Plate</i> on page 175.
	Clogged or damaged nozzle	Turn off the stream, remove the nozzle, and examine the nozzle tip under a microscope. <ul style="list-style-type: none"> • If debris is visible, clean the nozzle. See <i>Cleaning a Nozzle</i> on page 198. • If the nozzle appears damaged, replace it. See <i>Changing the Nozzle</i> on page 140.
Stream control disabled or no stream when Stream control clicked	Plenum not full	Wait for the plenum to fill.
	Air lock in filter	Prime the system with the corresponding fluid. If the control is still disabled, remove the filter, install bypass tubing, and repeat the priming procedure until you see fluid in the line. When fluid is running through the line, remove the bypass tubing, install the filter, and repeat the priming procedure one last time.
	Communication failure between workstation and instrument	Quit the software and restart it.

Troubleshooting the Stream (continued)





Observation	Possible Causes	Recommended Solutions
No stream when Stream control clicked	Sheath container low or empty	<p>Refill the sheath tank. See Refilling Containers on page 103.</p> <p>Note that when the empty tank warning message is not dismissed after 15 minutes, the stream shuts off automatically.</p>
	Air in sheath line	Prime the sheath tank. See Prime After Tank Refill on page 182.
	Air in filter	Purge the filter. See Purging Filters on page 192.
	Dry filter	<p>1 Install bypass tubing in place of the filter for the affected fluid, and run Prime After Tank Refill.</p> <p>2 Reinstall the filter and open the bleeder valve to purge the filter. See Purging Filters on page 192.</p>
Fanning around center stream	Nozzle inserted improperly	Reinsert the nozzle. Push it gently all the way forward without rocking it from side to side.
Unstable stream	Debris in flow cell or nozzle	Remove the nozzle and run the stream with no nozzle in place for approximately 1 second. (Click the Stream control on, and then off.) Sonicate the nozzle and reinstall it.

Troubleshooting the Stream (continued)

Observation	Possible Causes	Recommended Solutions
Leaking or spraying around nozzle	Nozzle inserted improperly	Turn off the stream. Remove the nozzle and the grounding plate and thoroughly clean and dry the plate and the area around the plate. See <i>Cleaning the Nozzle and Grounding Plate</i> on page 175 for instructions.
	Extra O-ring blocking nozzle	Remove the nozzle and use a cotton swab to clear out the cuvette.
	Grounding plate inserted improperly	Make sure the grounding plate is inserted with the notched end toward you. See <i>Cleaning the Nozzle and Grounding Plate</i> on page 175.
Drop breakoff too long	Bubbles in flow cell	Open the flow cell access door and check for bubbles in the flow cell. If they are visible, turn off the stream, wait a few seconds, and turn on the stream again.
	Attenuation on	Turn off attenuation.
	Amplitude too low	Increase the amplitude until you can see drops. If you need a very high amplitude (>70 volts) to see drops, you might have air bubbles in the flow cell.
	Nozzle inserted improperly	Turn off the stream. Remove the nozzle and ensure that the O-ring is in place. Reinsert the nozzle at a slight downward angle to prevent loss or movement of the O-ring. Make sure the nozzle is completely seated against the back wall of the cuvette flow cell.

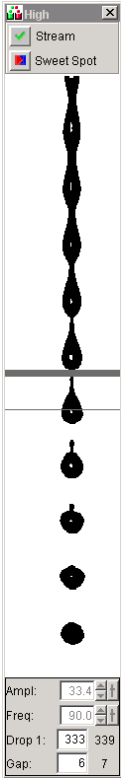
Troubleshooting the Breakoff

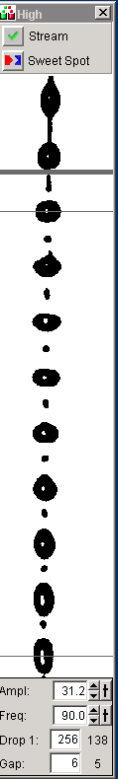
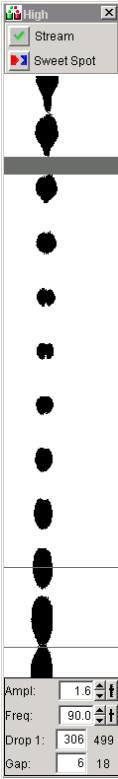
Use the following examples to help troubleshoot problems with the breakoff image.

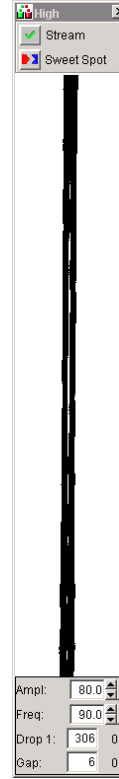
 <p>Ampl: 33.4 Freq: 90.0 Drop 1: 333 339 Gap: 6 7</p>	Abnormal Stream Image	 <p>Ampl: 8.6 Freq: 90.0 Drop 1: 306 71 Gap: 6 30</p>	 <p>Ampl: 31.2 Freq: 90.0 Drop 1: 256 138 Gap: 6 5</p>	 <p>Ampl: 1.6 Freq: 90.0 Drop 1: 306 499 Gap: 6 18</p>	 <p>Ampl: 44.6 Freq: 90.0 Drop 1: 306 485 Gap: 6 27</p>	 <p>Ampl: 80.0 Freq: 90.0 Drop 1: 306 0 Gap: 6 0</p>
<p>Normal stream image</p>		Possible Causes Recommended Solutions	<p>Nozzle inserted improperly</p> <p>Remove the nozzle and reinsert it.</p>	<p>Nozzle inserted improperly</p> <p>Remove the nozzle and reinsert it.</p>	<p>Partial clog</p> <p>Remove the nozzle, clean it, and then reinsert it.</p>	<p>Wet or dirty strobe lens</p> <p>Clean the lens as described in Cleaning the Camera Windows on page 200.</p>

Sorting Troubleshooting

Observation	Possible Causes	Recommended Solutions
Unstable breakoff while Sweet Spot engaged	Target Drop 1 value out of range for drop spacing	Use an actual Drop 1 value for the target. Remember to repeat the drop delay setup each time the target value is changed.
	Nozzle clogged or inserted improperly	Turn off the stream. Remove the nozzle and clean it. Reinsert the nozzle at a slight downward angle to prevent loss or movement of the O-ring. Make sure the nozzle is completely seated against the back wall of the cuvette flow cell.
	Dirty strobe lens or upper camera window	Clean the lens and the window as described in <i>Cleaning the Camera Windows</i> on page 200.
Center stream image dim or not visible in Side Stream window	Stream not intercepting BD AccuDrop laser	Adjust the micrometer dial on the BD AccuDrop laser to make the stream intercept as bright as possible. See Figure 1-17 on page 41.
Center stream off center when plate voltage turned on	Voltage Center too low or too high	Adjust the Voltage Center slider to put the center stream back to center.
	Saline spray on deflection plates or in sort block	Clean the deflection plates and the area around them.
Arcing between deflection plates	Plates too close together at the top	Adjust the plates so there is a gap of approximately 0.28 in. (0.7 cm) between them at the top.
	Salt bridge	Clean and dry the deflection plates and the area around and behind the plates.

Sorting Troubleshooting (continued)

Observation	Possible Causes	Recommended Solutions
ACDU sorting failure	Insufficient stream voltage	Increase the voltage for the far left stream.
	Splash shield not installed	Install the splash shield. See Installing the Sorting Hardware on page 153.
No deflection or insufficient deflection	Insufficient voltage	<ul style="list-style-type: none"> • Increase the plate voltage. • Increase the side-stream voltages using the slider controls.
	Stream-charging wire loose or missing	Verify the stream-charging wire is inserted all the way into the nozzle.
	Salt bridge	Turn off the stream. Remove the nozzle and the grounding plate and thoroughly clean and dry the plate and the area around the plate. See Cleaning the Nozzle and Grounding Plate on page 175 for instructions.
	Plates too far apart at top	Adjust the plates so there is a gap of approximately 0.28 in. (0.7 cm) between them at the top.
	Sorting paused because actual Drop 1 value out of range	<p>Wait until the Sweet Spot adjusts the amplitude to achieve the Drop 1 target.</p> <p>If this happens repeatedly during sorting, you could have debris in the nozzle or flow cell. See Troubleshooting the Stream on page 204 for suggestions.</p>

Sorting Troubleshooting (continued)

Observation	Possible Causes	Recommended Solutions
Fanning around center or side streams	Nozzle inserted improperly	Turn off the stream. Remove the nozzle and ensure that the O-ring is in place. Reinsert the nozzle at a slight downward angle to prevent loss or movement of the O-ring. Make sure the nozzle is completely seated against the back wall of the cuvette flow cell.
	Sweet Spot off	Turn on the Sweet Spot.
	Incorrect Sort Precision mode	Verify that the Sort Precision mode is appropriate for your sorting requirements. See Sort Precision Modes on page 73.
	2nd, 3rd, 4th Drop values not optimized	Adjust the 2nd, 3rd, and 4th Drop settings to tighten the center stream and fine-tune the side streams.
Sort button disabled	Particles too big for nozzle	Change the nozzle. See Changing the Nozzle on page 140.
	Acquisition pointer not set to current Tube	Click to move the Acquisition pointer in front of the appropriate Tube.
Population not listed in Add menu on Sort Layout	Population defined using Snap-To gate	Redefine the population using another gate type.
	Viewing Sort Layout for another Tube	Open or create a Sort Layout for the current acquisition Tube.
Sort Layout counters not updating	Viewing Sort Layout for another Tube	Open or create a Sort Layout for the current acquisition Tube.

Sorting Troubleshooting (continued)

Observation	Possible Causes	Recommended Solutions
High sort conflict rate	Event rate too high for drop drive frequency	Decrease the event rate.
	Gating conflict	Verify the gating hierarchy.
	Purity Mask too high	Decrease the Purity Mask.
Erratic sort rate	Flow Rate too high	Decrease the Flow Rate.
Unexpected sort results	Incorrect drop delay	Reset the drop delay. See Determining the Drop Delay on page 145.
	Incorrect Sort Precision mode	Verify that the Sort Precision mode is appropriate for your sorting requirements. See Sort Precision Modes on page 73.
	Sweet Spot off	Keep the Sweet Spot on during sorting.
	Drop 1 changed after setting drop delay	Reset the drop delay each time you change the Drop 1 value. See Determining the Drop Delay on page 145.
	Laser delay changed after setting drop delay	Reset the drop delay each time you change the laser delay. See Determining the Drop Delay on page 145.
	Incorrect logic in Population Hierarchy	Verify the gating strategy.

Sorting Troubleshooting (continued)

Observation	Possible Causes	Recommended Solutions
Unexpected sort results (continued)	Sorting parent and child populations into two different tubes	<p>If you try to sort a parent and its child population into two tubes, BD FACSDiVa software ignores the child events in both tubes.</p> <p>Create a new subset under the parent population consisting of NOT (Child). Sort the child population into one tube and the NOT (Child) population into another tube.</p>

Acquisition Troubleshooting

Observation	Possible Causes	Recommended Solutions
No events in plots after clicking Load or Acquire	Acquisition pointer not set to current Tube	Click to move the Acquisition pointer in front of the appropriate Tube.
	Laser shutter engaged	Make sure the flow cell access door is completely closed.
	Laser power off	Turn on the laser power.
	Viewing plots for a different Tube	Double-click the current Tube in the Browser to display the plots for that Tube.
	Incorrect population(s) in plot	Right-click the plot and choose Show Populations. Verify that the appropriate populations are displayed.

Acquisition Troubleshooting (continued)

Observation	Possible Causes	Recommended Solutions
No events in plots after clicking Acquire (continued)	Uncolored events in plot	<ul style="list-style-type: none"> • Format the plot to display all events. • Assign a color to the population displayed in the plot. • Verify the population drawing order.
	Current Instrument Configuration different from optical setup	Verify that the instrument optics setup matches the current Instrument Configuration. See Application Options on page 232.
	No sample in tube	Add sample to tube or install new sample tube.
	Sample not mixed properly	Increase the Sample Agitation rate. See Sample Agitation on page 81.
	Threshold not set to correct parameter (usually FSC)	Set the threshold to the correct parameter for your application.
	Multiple Threshold parameters not set correctly	Verify that the correct Boolean logic (And/Or) was used for the Threshold parameters.
	Threshold channel too low or too high	Adjust the Threshold channel. See Adjusting the Voltages and Threshold on page 124.
Optical filter(s) not completely seated	Make sure the filters are pushed all the way in.	

Acquisition Troubleshooting (continued)

Observation	Possible Causes	Recommended Solutions
No fluorescent signal	Current Instrument Configuration different from optical setup	Verify that the instrument optics setup matches the current Instrument Configuration.
	Wrong filter installed or filter not completely seated	Make sure the appropriate filter is installed for each fluorochrome; see Application Options on page 232 for suggestions. Make sure the filters are pushed all the way in.
	Laser delay set incorrectly	Adjust the laser delay settings. See Instrument Quality Control on page 105.
Low Area signal	Area Scaling factor too low	Adjust Area Scaling for the corresponding laser. See Instrument Quality Control on page 105.
Unexpected events in plot	Incorrect logic in Population Hierarchy	Verify the gating strategy.
	Incorrect population(s) in plot	Right-click the plot and choose Show Populations. Verify that the appropriate populations are displayed.
	Incorrect drawing order	Verify that the required population is not hidden by another population. Right-click the plot and choose Order Populations by Count.

Acquisition Troubleshooting (continued)

Observation	Possible Causes	Recommended Solutions	
Unexpectedly high event rate	Threshold channel too low	Adjust the Threshold channel. See Adjusting the Voltages and Threshold on page 124.	
	Sample too concentrated	Dilute the sample.	
	Event rate too high	Decrease the Flow Rate in the Acquisition Controls frame.	
	Bubbles in flow cell	Turn off the stream, wait a few seconds, and turn on the stream again.	
Unexpectedly low event rate	Sample not adequately mixed	Increase the Sample Agitation rate. See Sample Agitation on page 81.	
	Threshold channel too high	Adjust the Threshold channel. See Adjusting the Voltages and Threshold on page 124.	
	Sample too dilute	Concentrate the sample.	
	Sample line clogged	Perform a sample line backflush. See Sample Line Backflush on page 180. If necessary, change the sample line.	
	Sample line clogged or kinked	Backflush the sample line. See Sample Line Backflush on page 180.	Look for visible kinks in the line. If kinks are noted, change the sample line. See Changing the Sample Lines on page 194.
	Sample line installed incorrectly	Verify the sample line installation. See Changing the Sample Lines on page 194.	
Sample aggregates	Filter the sample.		

Acquisition Troubleshooting (continued)

Observation	Possible Causes	Recommended Solutions
Distorted parameters or high CVs	Instrument settings adjusted incorrectly	Optimize the scatter parameters. See Adjusting the Voltages and Threshold on page 124.
	Flow rate too high	Decrease the Flow Rate in the Acquisition Controls frame.
	Window Extension too low	Increase the Window Extension.
	Bubbles in flow cell	Turn off the stream, wait a few seconds, and turn on the stream again.
	Nozzle clogged or dirty	Clean the nozzle as described in Cleaning a Nozzle on page 198.
	Flow cell dirty	Clean the flow cell with a detergent such as Contrad. See Clean Flowcell on page 181. Let the detergent sit for 5 minutes before turning on the stream.
	Poor sample preparation	Repeat sample preparation.
	Area scaling factor too low	Verify area scaling. See Verifying Area Scaling and Laser Delay on page 112.
Excessive amount of debris in plots	Threshold channel too low	Increase the Threshold channel. See Adjusting the Voltages and Threshold on page 124.
	Dead cells or debris in sample	Examine the sample under a microscope.
	Sample contaminated	Re-stain the sample, making sure the tube is clean.

Acquisition Troubleshooting (continued)

Observation	Possible Causes	Recommended Solutions
High electronic abort rate (>10% of system event rate)	Window Extension too high	Decrease the Window Extension.
	Threshold channel too low	Increase the threshold channel.
	Event rate too high	Decrease the Flow Rate in the Acquisition Controls frame.
	Sample aggregated	Filter the sample.
	Sample too concentrated	Dilute the sample.
Fewer events than expected in gated population	Window Extension set incorrectly	Adjust the Window Extension. Refer to the <i>BD FACSDiVa Software User's Guide</i> , if needed.
	Laser delay set incorrectly	Adjust the laser delay settings. See Instrument Quality Control on page 105.
	Plot zoomed	Unzoom the plot or make the gate bigger.
	Events left out of gate	When drawing a gate, make sure events on the axis are included.
Increasing threshold results in decreased Area signal	Window Extension too low	Slightly increase the Window Extension to maximize Area signal.
		 NOTICE Increasing the Window Extension too much results in more electronic aborts or high CVs.
Area measurement off-scale while the Height measurement is on scale	Area Scaling factor too high	Decrease the Area Scaling factor to move the Area measurement back on scale. If necessary, adjust Area Scaling to make the Area measurement match the Height measurement.

Fluidics Cart Troubleshooting

Observation	Possible Causes	Recommended Solutions
No fluid in line during system prime	Air lock in filter	Remove the filter for the corresponding fluid, install bypass tubing, and run Prime After Tank Refill. Repeat the priming procedure until you see fluid in the line. When fluid is running through the line, remove the bypass tubing, install the filter, and repeat the priming procedure one last time.
Long clean fails	Air lock in filter	See previous recommendations.
	Fluid line detached	Verify the fluid line connections on the fluidics cart and on the instrument. Push firmly on each line to ensure it is connected.
Fluidics cart air flow <70 psi	Air leak	Contact your BD Biosciences service engineer.
Fluidics cart air flow >100 psi	Regulator not adjusted properly	Contact your BD Biosciences service engineer.
Fluid leak under fluidics cart or below side door	Condensation from pressure relief valve	This is a normal phenomenon that occurs when water is condensed from room air. Condensation is greater in humid environments. To avoid slipping, check and wipe up the water daily.
	Bleeder valve open	Check and close all bleeder valves. See Purging Filters on page 192.
	Broken fluid line	Contact BD Biosciences.

Electronics Troubleshooting

Observation	Possible Causes	Recommended Solutions
“Instrument Disconnected” in Instrument frame	Instrument power off	Turn on the instrument main power.
	Communication failure between workstation and instrument	<ul style="list-style-type: none"> • Quit the software and then restart it. • If restarting does not work, reset the instrument electronics: switch off the main power, wait 10 seconds until the system is fully depressurized, and then switch the power back on. • Restart the computer and the instrument.
	Ethernet cable disconnected between workstation and instrument	Unplug and then plug in the cable connectors and make sure they are secure.
	IP address changed	Enter the correct IP address. Call BD Biosciences for assistance.
“Master DAQ Overflow” in Instrument frame	Event rate too high	Decrease the event rate or verify the threshold.
“Instrument not responding” in Status tab	Unknown	Perform the suggestions for a communication failure, above.

Appendix A

Supplies and Options

This appendix provides a list of supplies and options that are available for the BD FACSAria instrument.

- To order spare parts and consumables from BD Biosciences from within the US, call: (877) 232-8995 or go to www.bdbiosciences.com.

In other countries, contact your local BD Biosciences representative.

- To order instrument options, contact your sales representative.

NOTICE This information is correct at the time of publication; for up-to-date information refer to our website (<http://www.bdbiosciences.com>).

Instrument Supplies

Optical Components

The following filters and mirrors are mounted on the BD FACSAria instrument. Use these part numbers if you need to order any replacement components.

Detector Array (Laser)	PMT	LP Mirror BP Filter	Replacement Part No.	Intended Dye
Octagon (488-nm blue laser)	A	735	334751	
		780/60	19-62774-18	PE-Cy7
	B	655	334752	
		695/40	19-62774-16	PerCP-Cy5.5 or PI
		675/20	19-62774-02	PerCP alone
	C	595	334753	
		610/20	19-62774-14	PE-Texas Red
	D	556	334754	
		575/26	19-62774-02	PE or PI
		585/42	19-62774-03	Alternative for PE/PI when not using PE-Texas Red
E	502	334755		
	530/30	19-62774-00	FITC	
F	488/10	53-10084-00	SSC	
Trigon (633-nm red laser)	A	735	19-62774-18	
		780/60	19-62774-18	APC-Cy7
	B	660/20	19-62774-05	APC

The following filters and mirrors are provided with the violet-laser option.

Detector Array (Laser)	PMT	LP Mirror BP Filter	Replacement Part No.	Intended Dye
Trigon (407-nm violet laser)	A	502	334755	
		530/30	19-62774-00	Alexa Fluor 430
	B	450/40	334548	Cascade blue, Pacific blue, Hoeschst, DAPI, Alexa Fluor 405

Accessory Kit

The instrument is shipped with an accessory kit containing the following items. Use these part numbers if you need to order any replacements.

Item	Part No.
1-mL microtube holder	333457
12 x 75-mm test-tube holder	333456
15-mL centrifuge-tube holder	333430
Four-way 1-mL collection tube holder	345898
Four-way 12 x 75-mm collection tube holder	333532
Two-way 12 x 75-mm collection tube holder	334904
Two-way 15-mL collection tube holder	345896
Spare nozzles:	
• 70 micron	• 335474
• 100 micron	• 335475
Nozzle O-rings (bag of 30)	333084

Item	Part No.
Sample injection tubing (three 12-in. lengths)	335598
HPLC valve tubing (three 7-in. lengths)	335599
Ferrules (package of 10)	335108
Ferrule-removal tool	335690
Nozzle-lever spring	333081
Nozzle-lever plunger	345888
Fluidics cart tubing replacement kit: <ul style="list-style-type: none"> • 1/4 x 1/8-in. sheath tubing (96-in. length, blue) • 1/4 x 1/8-in. waste tubing (288-in. length, orange) • 3/8 x 1/4-in. air tubing (96-in. length, clear) • 3/8 x 1/4-in. waste tubing (96-in. length, yellow) • Fluidics cart power cord 	335457
Fluid filter assembly (Pall SuporCap 50, 0.2 μm)	335663
Bypass tubing assembly (tubing and quick-disconnect fittings)	TBD
Adaptor tray for microscope slides	333681
ACDU splash shield	334909
Power cords: <ul style="list-style-type: none"> • Main power cord • Cordset for continental Europe • Cordset for UK • Cordset for Australia/Asia 	<ul style="list-style-type: none"> • 333694 • 334140 • 334141 • 334175
Hex wrench set	98-10004-00

Other Replacement Parts

The following items are not included in the accessory kit, but you can use the indicated part numbers to order spare or replacement parts.

Item	Part No.
Autoclavable 10-L container	333503
Auxiliary 5-L container	333504
Sheath sensor probe (5-level)	334914
Waste sensor probe (6-level)	334915
Auxiliary sensor probe (1-level)	334911
Air filter for plenum cabinet (side door)	334351
Air filter for ACDU cabinet	334821 (single) 333595 (set of 3)
ULPA filter and tubing replacement kit (set of 3, for use with the AMO)	334822

Consumables

Instrument Setup Particles

Particle	Supplier	Catalog No.
BD CaliBRITE Beads <ul style="list-style-type: none"> • Two-color kit (unlabeled, FITC, PE) • Three-color kit (unlabeled, FITC, PE, PerCP) • PerCP beads • PerCP-Cy5.5 beads • APC beads 	BD Biosciences (877) 232-8995	<ul style="list-style-type: none"> • 349502 • 340486 • 340497 • 345036 • 340487
Fluoresbrite Yellow-Green 2- μ m beads (for the 407-nm laser)	Polysciences Inc. (800) 523-2575	18604
SPHERO Rainbow Calibration Particles (8 peaks), 3.0–3.4 μ m	BD Biosciences Pharmingen (877) 232-8995	559123
	Spherotech, Inc. (800) 368-0822	Assorted particles
BD CompBeads	BD Biosciences (877) 232-8995	TBD
DNA QC Particles kit	BD Biosciences (877) 232-8995	349523

Reagents

Reagent	Supplier	Catalog No.
BD FACSTheath fluid	BD Biosciences (877) 232-8995	340398 (US and Latin America) 342003 (other countries)
BD FACSRinse detergent	BD Biosciences	340346
BD FACSClean solution	BD Biosciences	34xxxx
Ethanol	Various	–
Chlorine bleach (5% sodium hypochlorite)	Clorox or other major supplier (to ensure that the bleach is at the correct concentration and free of particulate matter)	–
Monoclonal antibodies	BD Biosciences	– ^a
Dyes and fluorochromes	Molecular Probes (800) 438-2209 Sigma (800) 325-3010	–
BD FACS Lysing Solution	BD Biosciences	349202

a. Refer to the BD Biosciences Immunocytometry Products Catalog or the BD Biosciences website (www.bdbiosciences.com).

Labware

Item	Supplier	Catalog No.
1-mL microtubes	Bio-Rad Laboratories (800) 424-6723	223-9391 (1,000 per box)
5-mL polystyrene test tubes, 12 x 75-mm (BD Falcon) <ul style="list-style-type: none"> • uncapped, 125 per bag • capped, 125 per bag • capped, 25 per bag • with cell-strainer cap, 25 per bag 	BD Biosciences (877) 232-8995	<ul style="list-style-type: none"> • 352052 • 352054 • 352058 • 352235
15-mL conical centrifuge tubes (BD Falcon) <ul style="list-style-type: none"> • Polypropylene, 50/bag • Polypropylene, 125/bag • Polypropylene, 50/rack • Polystyrene, 125/bag • Polystyrene, 50/rack 	BD Biosciences (877) 232-8995	<ul style="list-style-type: none"> • 352196 • 352096 • 352097 • 352095 • 352099

Instrument Options

Your BD FACSAria instrument can be upgraded with the following options. Contact your sales representative for more information.

Third-laser option	The third-laser option upgrades your instrument with a violet laser, a trigon, and two PMTs for greater flexibility in analysis and sorting.
Optical upgrade	Optical upgrades are available for two- and three-laser systems to maximize the detection capabilities of the instrument. Each upgrade includes detectors and electronics to detect three or four additional colors, respectively.
Aerosol Management Option (AMO)	The AMO helps contain aerosols by evacuating the sort collection chamber during sorting. The option includes a vacuum source attached to an ultra-low penetrating air (ULPA) filter.
Temperature-control option	This option can be used to control the temperature of sorted samples using a recirculating water bath and metal collection tube holders.
Automated cell deposition unit (ACDU)	The ACDU option provides hardware that allows you to sort into multiwell plates and onto slides.

Application Options

The octagon and trigon detector arrays in the BD FACSAria instrument allow many different combinations of mirrors and filters. The following illustrations show how the collection optics are configured for a two- and three-laser system.

Two-Laser System

This is the standard configuration for a two-laser system.

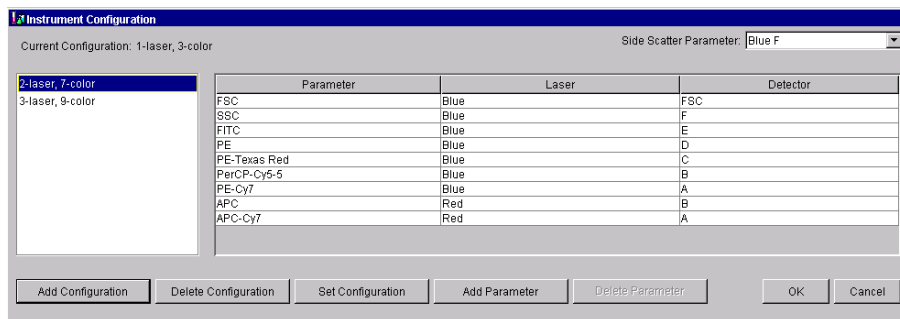
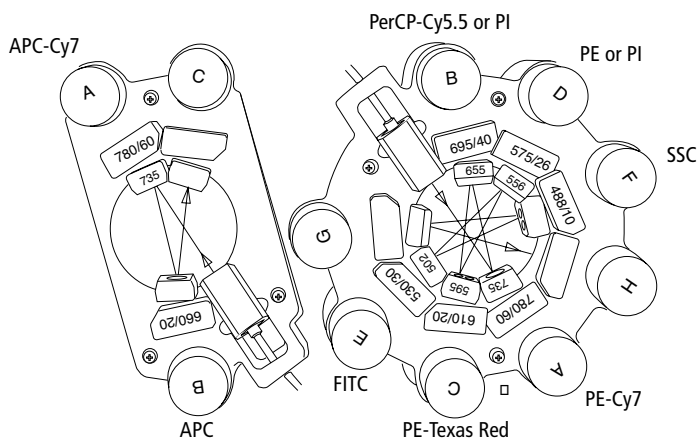

Three-Laser System

This is the standard configuration for a three-laser system.

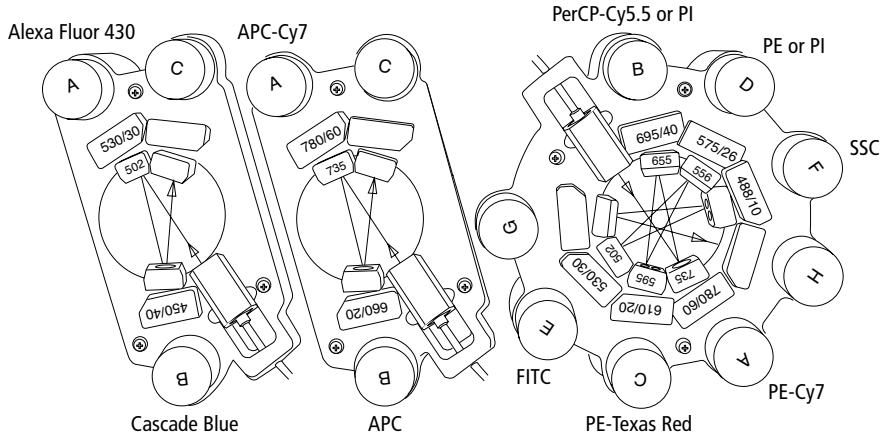

Instrument Configuration

Current Configuration: 3-laser, 9-color Side Scatter Parameter: Blue F

Parameter	Laser	Detector
FSC	Blue	FSC
SSC	Blue	F
FITC	Blue	E
PE	Blue	D
PE-Texas Red	Blue	C
PerCP-Cy5-5	Blue	B
PE-Cy7	Blue	A
APC	Red	B
APC-Cy7	Red	A
Violet1	Violet	B
Violet2	Violet	A

Buttons: Add Configuration, Delete Configuration, Set Configuration, Add Parameter, Delete Parameter, OK, Cancel

Custom Configuration

Use the following worksheet to set up a custom configuration.

Configuration Name: _____

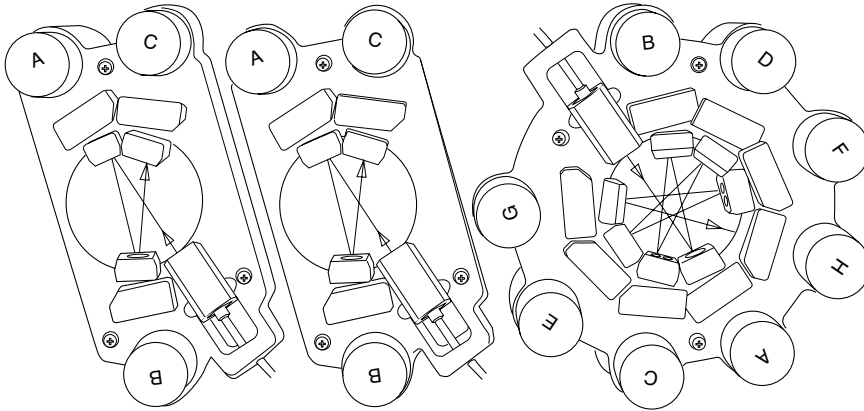

Detector	Fluorochrome	LP Mirror	BP Filter
Violet C			
Violet B			
Violet A			
Red C			
Red B			
Red A			
Blue H			
Blue G			
Blue F			
Blue E			
Blue D			
Blue C			
Blue B			
Blue A			

Changing Filters

Note that two extra filters are provided in the accessory kit.

- If you are using PerCP rather than PerCP-Cy5.5 in the Blue B position, replace the 695/40 filter with the 675/20 filter to decrease the amount of spectral overlap.
- If you are using both PE and PE-Texas Red in your experiment, replace the 585/42 filter in the Blue D position with the 575/26 filter to optimize the detection of each fluorophore.

If you want to install a custom filter or dichroic, the filter should comply with the following specifications.

Table A-1 BD FACSAria filter specifications

Filter Characteristic	Dichroic LP Filters	BP Filters
Diameter	0.622 ±0.003 in.	1.00 ±0.010 in.
Thickness	0.125 ±0.005 in.	0.12–0.35 in.
Minimum clear aperture	0.562 in.	0.85 in.
Incident angle	11 ±1°	0°

For the longpass filters, the surface that faces into the center of the octagon/trigon should be coated directly on its surface, not between two or more pieces of glass. The coating should transmit ≥70% of the required wavelength range where you want the mirror to reflect light, with a minimum transmission of ≥50%, and a minimum reflection of ≥95%.

The opposite surface (facing away from the center) should be coated with an anti-reflective coating with a minimum reflection of ≤1% of the wavelength range where you want the mirror to transmit light.

Note that filters must be installed in front of each PMT to block unwanted laser light.

You can order a filter holder using the following part numbers.

Holder	Part No.
Mirror holder	342971
Mirror retainer	345662
Mirror backup spring	334979
Filter holder	333814
Filter retainer	333817

For the dichroic, carefully assembly the glass filter in the holder using the retaining spring. Assemble the filter with the arrow pointing toward the center of the octagon or trigon. The angle of the dichroic is critical to achieving optimal results.

Note that any time you modify a detector array, you will need to create a new Instrument Configuration to identify which PMT (identified by laser color and letter) will detect the emitted light. See *Defining a New Configuration* on page 236 for instructions.

Defining a New Configuration

BD FACSDiVa software is provided with default configurations specific to your instrument; additional custom configurations can be defined. You can switch between predefined configurations by selecting the appropriate configuration name, and then clicking Set Configuration.

- Tip** Create one configuration that lists all the fluorochromes used in your laboratory, so the same configuration can be used for all Experiments. Changing instrument configurations within the same Experiment can generate errors.
- Tip** To ensure that an Experiment contains the correct parameters, set the configuration you want to use *before* creating a new Experiment.

- 1 Choose Instrument > Instrument Configuration.

The Instrument Configuration dialog box appears.

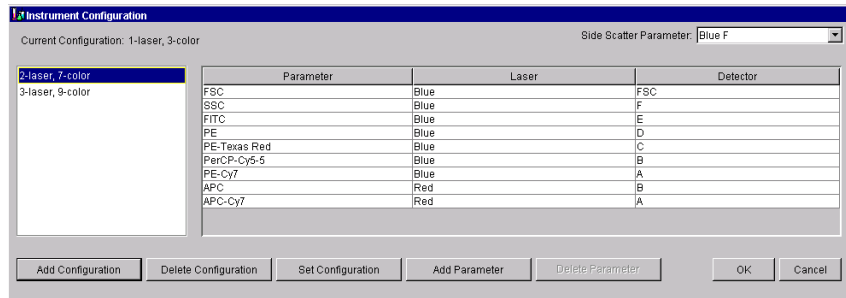

- 2 Click the Add Configuration button.

Alternatively, you can use the Add Parameter button to add parameters to an existing configuration. You can define multiple parameters for the same Laser/Detector position, and within each Experiment, use the Parameter tab in the Tube Inspector to specify which parameter to detect. Only one parameter can be detected from each PMT per Experiment.

NOTICE Instrument configurations that have a compensation Setup associated with them cannot be edited. To edit an existing configuration, all Setups associated with the configuration must be deleted from the Setup catalog.

NOTICE Use the Experiment Layout dialog box to label Tubes with reagents. Do not use the Instrument Configuration dialog box.

- 3 Name the configuration, and click OK.
- 4 Select the new configuration in the list of configurations; click once on the Add Parameter button for each parameter to be added.
- 5 Specify a laser and detector for each parameter; enter parameter names in the corresponding Parameter fields.

Use the drop-down menus to choose lasers and detectors. You must choose a detector before you can edit the Parameter field.

Your Laser selection determines the number of choices in the Detector menu (ie, the Blue laser allows seven detector choices, while the Red laser allows only three). Remember to order your fluorochromes from longest wavelength to shortest.

- 6 Use the drop-down menu at the top of the dialog box to assign the side-scatter parameter.

You must assign SSC to ensure the parameter is excluded from the compensation matrix. Once it has been assigned, the SSC Parameter field cannot be edited.

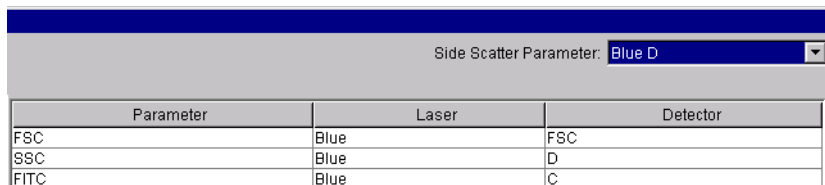

Side Scatter Parameter: Blue D

Parameter	Laser	Detector
FSC	Blue	FSC
SSC	Blue	D
FITC	Blue	C

- 7 To make the new configuration the current configuration, click Set Configuration; then click OK.

⚠ NOTICE You must click Set Configuration for the new configuration to apply. For accurate data results, always verify that the instrument optics setup matches the current Instrument Configuration.