

Bridging the gap between growth theory and the new economic geography: The spatial Ramsey model*

R. Boucekkine[†] C. Camacho[‡] B.Zou[§]

September 2007

Abstract

We study a Ramsey problem in infinite and continuous time and space. The problem is discounted both temporally and spatially. Capital flows to locations with higher marginal return. We show that the problem amounts to optimal control of parabolic partial differential equations (PDEs). We rely on the existing related mathematical literature to derive the Pontryagin conditions. Using explicit representations of the solutions to the PDEs, we first show that the resulting dynamic system gives rise to *an ill-posed problem* in the sense of Hadamard (1923). We then turn to the spatial Ramsey problem with linear utility. The obtained properties are significantly different from those of the non-spatial linear Ramsey model due to the spatial dynamics induced by capital mobility.

Keywords: Ramsey model, Economic geography, Parabolic partial differential equations, optimal control.

Journal of Economic Literature: C61, C62, O41.

*We are grateful to Cuong Le Van, Omar Licandro, Dominique Peeters, Jacques Thisse, Vladimir Veliov and two anonymous referees for useful and stimulating comments. We acknowledge the financial support of the Belgian French speaking community (Grant ARC 03/08-302) and of the Belgian Federal Government (Grant PAI P5/10). The third author also acknowledges the financial support from German Science Foundation (DFG, grant GRK1134/1).

[†]CORE and Department of Economics, Université catholique de Louvain (Belgium), and Department of Economics, University of Glasgow (UK). boucekkine@core.ucl.ac.be

[‡]Department of Economics, Université catholique de Louvain. camacho@ires.ucl.ac.be

[§]IMW and CREA, University of Luxembourg. Benteng.ZOU@uni.lu

1 Introduction

The inclusion of the space dimension in economic analysis has regained relevance in the recent years. The emergence of a new economic geography is indeed one of the major events in the economic literature of the last decade (see Krugman, 1991 and 1993, Fujita, Krugman and Venables, 1999, and Fujita and Thisse, 2002). Departing from the early regional science contributions, which are typically based on simple flow equations (see Beckman, 1952, or more recently, Ten Raa, 1986, and Puu, 1982), the new economic geography models use general equilibrium frameworks with a refined specification of local and global market structures, and some precise assumptions on the mobility of production factors. Their usefulness in explaining the mechanics of agglomeration, the formation of cities, the determinants and implications of migrations, and more generally, the dynamics of the distributions of people and goods over space and time is undeniable, so undeniable that this discipline has become increasingly popular in the recent years.

Two main characteristics of the new economic geography contributions quoted just above are: (i) the discrete space structure, and (ii) the absence of capital accumulation. Typically, economic geographers use two-regions frameworks, mostly analogous to the two-country models usually invoked in trade theory. However, some continuous space extensions of these models have been already studied. In a continuous space extension of his 1993 two-region model, Krugman (1996) shows that the economy always displays regional convergence, in contrast to the two-region version in which convergence and divergence are both possible. Mossay (2003) proves that continuous space is not incompatible with regional divergence using a different migration scheme. In Krugman's model, migration follows utility level differentials, which in turn implies that location real wages provide the only incentive for moving (predominant regional convergence force). In Mossay, migrations **additionally**

depend on idiosyncrasies in location taste, inducing a divergence force, which can balance the utility gradient force mentioned before. As a consequence, regional divergence is a possible outcome in this model.

Both models, however, ignore the role of capital accumulation in migrations: They both assume zero (individual) saving at any moment. Indeed, the zero saving assumption is a common characteristic to the new economic geography literature, especially in continuous space settings, with the notable exception of Brito (2004). This strong assumption is done to ease the resolution of the models, which are yet very complex with the addition of the space dimension. The literature closest to this present paper was developed in the seventies by Isard and Liossatos (1979), where they studies a number of models both in discrete and continuous cases.

Nonetheless, as capital accumulation is not allowed, the new economic geography models are losing a relevant determinant of migrations, and more importantly, an engine of growth. While a large part of growth theory is essentially based on capital accumulation, the new economic geography has mainly omitted this fundamental dimension so far. It seems however clear that many economic geography problems (eg. uneven regional development) have a preminent growth component, and *vice versa*. Thus, there is an urgent need to unify in some way the two disciplines, or at least to develop some junction models.

This paper follows exactly this line of research. We study the Ramsey model with space. Space is continuous and infinite, and optimal consumption and capital accumulation are space dependent. A peculiar characteristic of Brito's framework is the non-Benthamain nature of the Ramsey problem: he considers an average utility function in space in the objective function. This is done in order to prevent the divergence of the objective integral function over an infinite space. In this paper we will work in the classical Benthamian case. We can do so by accounting for population density, which introduces a kind of spatial discounting therefore forc-

ing the convergence of the objective integral function even under an infinite space configuration.

Our modelling of space is done so as “to avoid simple but unrealistic boundary conditions” (Ten Raa, 1986, page 528–530). Capital is perfectly mobile across space (and of course, across time through intertemporal substitution, as usual in a Ramsey-like model). Capital flows from the regions with low return to capital to the regions with high return. In such a case, it has been already shown by Brito (2004) that capital, the state variable of the optimal control problem, is governed by a parabolic partial differential equation. This is indeed the main difficulty of the problem compared to the traditional regional science approach, as in Ten Raa (1986) and Puu (1982), where the considered fluid dynamics modelling gives rise to wave equations of income.

Establishing the Pontryagin conditions in our parabolic case with infinite time and infinite space is not a very difficult task, using the most recent advances in the related mathematical discipline, notably Raymond and Zidani (1998), and Lenhart and Yong (1992). See also Brito (2004) for his specific non-Benthamian Ramsey problem. Unfortunately, the asymptotic properties of the resulting dynamic systems are by now still unsolved in the mathematical literature. Actually, the asymptotic literature of partial differential equations (see for example, Bandle, Pozio and Tesei, 1987) has only addressed the case of scalar (or system of) equation(s) with initial values. In a Ramsey-like model, the intertemporal optimization entails a forward variable, consumption, and a transversality condition. As a result, the obtained dynamic system is no longer assimilable to a Cauchy problem, and it turns out that there is no natural transformation allowing to recover the characteristics of a Cauchy problem, specially for the asymptotic assessment.

In this paper, we take a step further. Using explicit integral representations of

the solutions to parabolic partial differential equations (see Pao, 1992, for a nice textbook in the field, and Wen and Zou, 2000 and 2002), we will clearly identify a serious problem with the optimal control of these equations: In contrast to the Ramsey model without space where there exists a one-to-one relationship between the initial value of the co-state variable, say $q(0)$, and the whole co-state trajectory, for a given capital stock path, this property does not hold at all in the spatial counterpart, that is $q(x, t)$, the co-state variable for location x at time t , is not uniquely defined by the data $q(0, x)$ because of the integral relationship linking $q(x, t)$ to $q(0, x)$. As a consequence, while the transversality conditions in the Ramsey model without space allows to identify a single optimal trajectory for the co-state variable, thus for the remaining variables of the model, there is no hope to get the same outcome with space. We are facing a typical *ill-posed problem* in the sense of Hadamard (1923): We cannot assure neither the existence, or the uniqueness of the solutions, nor the continuous dependence on the known initial-boundary conditions.

How to deal with this huge difficulty? One can try to extract special solutions to the dynamic system arising from optimization; this is the strategy adopted by Brito (2004) who looks for the existence of travelling waves, a nice solution concept intensively used in applied mathematics. In order to keep the possibility to compare with the traditional Ramsey model's solution paths, we study the case of the Ramsey model with linear utility. In such a case, we are -as usual- able to disentangle the forward looking dynamics from the backward-looking, which ultimately allows us to use the available asymptotic literature on scalar initial-value parabolic equations. Depending on the initial capital distribution, optimal consumption per location can be initially corner or interior, and the dynamics of capital accumulation across space and time will be governed by a scalar parabolic equation. We shall study whether an initially "corner" location (ie. with an initially corner consumption solution) can converge to its interior regime or to any other regime to be characterized. The

obtained properties are substantially different from those of the linear Ramsey model without space in many respects, due to the spatial dynamics induced by capital mobility. Indeed, capital accumulation in a given location will not only depend on the net savings of the individuals living at that location, as in the standard Ramsey model, but also on the trade balance of this location since capital is free to flow across locations. In this sense, the linear spatial Ramsey model is rich enough to serve as a perfect illustration of how the spatial dynamics can interact with the typical mechanisms inherent to growth models.

The paper is organized as follows. Section 2 states our general spatial Ramsey model with some economic motivations. It also derives the associated Pontryagin conditions using the recent related mathematical literature. Section 3 is one of the most crucial contributions of the paper: we study the existence and uniqueness of solutions to the dynamic system induced by the Pontryagin conditions and show via explicit integral representations of the solutions, that the latter problem is ill-posed. Section 4 is the detailed analysis of the linear utility case. We recall some of the properties of the linear Ramsey model without space. We then move to the spatial framework. The interior and corner solutions are first characterized. Then we study the convergence from below and from above the interior solution, assuming that *all* the locations start either below or above their interior regime. We study in depth the consequences of capital mobility on the asymptotic capital distribution across space. Section 5 concludes.

2 The general spatial Ramsey model

We describe here the ingredients of our Ramsey model, formulate the corresponding optimal control problem and give the associated Pontryagin conditions.

2.1 General specifications

We consider in this paper the following central planner problem

$$\max_c \int_0^\infty \int_{\mathbb{R}} U((c(x, t), x)) e^{-\rho t} dx dt, \quad (1)$$

where $c(x, t)$ is the consumption level of a representative household located at x at time t , $x \in \mathbb{R}$ and $t \geq 0$, $U(c(x, t), x)$ is the instantaneous utility function and $\rho > 0$ stands for the time discounting rate. For a given location x , the utility function is standard, i.e., $\frac{\partial U}{\partial c} > 0$, $\frac{\partial^2 U}{\partial^2 c} < 0$, and checking the Inada conditions. Our specification of the objective function can be interpreted as the following. Suppose that $U(c, x)$ is separable, $U(c, x) = V(c) \psi(x)$, with $V(\cdot)$ a strictly increasing and concave function, and $\psi(x)$ an integrable and strictly positive function such that $\int_{\mathbb{R}} \psi(x) = 1$. In such case, the presence of x *via* $\psi(x)$ in the integrand of the objective function stands for the location's x population density. Further assumptions on the shape of preferences with respect to x will be done along the way.

We now turn to describe the law of motion of capital: How capital flows from a location to another. Hereafter we denote by $k(x, t)$ the capital stock held by the representative household located at x at date t . In contrast to the standard Ramsey model, the law of motion of capital does not rely entirely on the saving capacity of the economy under consideration: The net flows of capital to a given location or space interval should also be accounted for. Suppose that the technology at work in location x is simply $y(x, t) = A(x, t)f(k(x, t))$, where $A(x, t)$ stands for total factor productivity at location x and date t and could be another heterogeneity factor, and $f(\cdot)$ is the standard neoclassical production function, which satisfies the following assumptions:

(A1) $f(\cdot)$ is non-negative, increasing and concave;

(A2) $f(\cdot)$ verifies the Inada conditions, that is,

$$f(0) = 0, \quad \lim_{k \rightarrow 0} f'(k) = +\infty, \quad \lim_{k \rightarrow +\infty} f'(k) = 0.$$

Moreover we assume that the production function is the same whatever is the location. Hence the budget constraint of household $x \in \mathbb{R}$ is

$$\frac{\partial k(x, t)}{\partial t} = A(x, t)f(k(x, t)) - \delta k(x, t) - c(x, t) - \tau(x, t), \quad (2)$$

where δ is the depreciation rate of capital¹, and $\tau(x, t)$ is the household's net trade balance of household x at time t , and also the capital account balance, by the assumption of homogenous depreciation rate of capital, no arbitrage opportunities. Since the economy is closed, we have

$$\int_{\mathbb{R}} \left(\frac{\partial k(x, t)}{\partial t} - A(x, t)f(k(x, t)) + \delta k(x, t) + c(x, t) + \tau(x, t) \right) \psi(x) dx = 0.$$

From (2), it is easy to see for any $[a, b] \subset \mathbb{R}$, it follows

$$\int_a^b \left(\frac{\partial k(x, t)}{\partial t} - A(x, t)f(k(x, t)) + \delta k(x, t) + c(x, t) + \tau(x, t) \right) \psi(x) dx = 0. \quad (3)$$

The net trade balanced in region $X = [a, b]$ equals to capital flows received from locations lying to the left of a minus that flowing away to the right of b . Therefore the net trade balanced at location x can be rewritten as

$$\tau(x, t) = - \lim_{dx \rightarrow 0} \frac{\frac{\partial k(x+dx, t)}{\partial x} - \frac{\partial k(x, t)}{\partial x}}{dx} = - \frac{\partial^2 k}{\partial x^2}.$$

Capital movements tend to eliminate geographical differences and we suppose

that there are no institution barriers to capital flows (or do not consider the adjustment speed)^{2 3}. Without inter-regional arbitrage opportunities, capital flows from regions with lower marginal productivity of capital to the higher ones. Consequently capital flows from regions with abundant capital toward the ones with relatively less capital.

Substituting the above equation into equation (3), we have $\forall X \subset \mathbb{R}, \forall t$

$$\int_X \left(\frac{\partial k(x, t)}{\partial t} - \frac{\partial^2 k(x, t)}{\partial x^2} - A(x, t)f(k(x, t)) - c(x, t) - \delta k(x, t) \right) \psi(x) dx = 0.$$

Given $\psi(x) > 0$, the budget constraint can be written as (see Appendix)⁴:

$$\frac{\partial k(x, t)}{\partial t} - \frac{\partial^2 k(x, t)}{\partial x^2} = A(x, t)f(k(x, t)) - \delta k(x, t) - c(x, t), \quad \forall(x, t). \quad (4)$$

The initial distribution of capital, $k_0(x)$, is assumed to be known, bounded and continuous. Moreover, we assume that, if the location is far away from the origin, there is no capital flow⁵, that is

$$\lim_{x \rightarrow \pm\infty} \frac{\partial k(x, t)}{\partial x} = 0.$$

The new term $\frac{\partial^2 k(x, t)}{\partial x^2}$ in the budget constraint (4) is the spacial ingredient of the dynamics of capital accumulation, it simply captures capital mobility across space. It is a parabolic partial differential equation, and as argued in the introduction of the paper, it complicates tremendously the treatment of the associated optimal control problem. We shall precisely identify the source of this complication. Before let us present briefly our optimal control problem.

2.2 The optimal control problem

We can write our optimal control problem as follows

$$\max_c \int_0^\infty \int_{\mathbb{R}} U(c(x,t), x) e^{-\rho t} dx dt. \quad (5)$$

subject to:

$$\left\{ \begin{array}{l} \frac{\partial k(x,t)}{\partial t} - \frac{\partial^2 k(x,t)}{\partial x^2} = A(x,t)f(k(x,t)) - \delta k(x,t) - c(x,t), \quad (x,t) \in \mathbb{R} \times [0, \infty), \\ k(x,0) = k_0(x) > 0, \quad x \in \mathbb{R}, \\ \lim_{x \rightarrow \pm\infty} \frac{\partial k(x,t)}{\partial x} = 0, \quad t \geq 0. \end{array} \right. \quad (6)$$

Here comes the definition of an optimal solution:

Definition 1 A trajectory $(c(x,t), k(x,t))$, with $k(x,t)$ in ⁶ $C^{2,1}(\mathbb{R} \times [0, \infty))$ and $c(x,t)$ piecewise- $C^{2,1}(\mathbb{R} \times [0, \infty))$, is admissible if $k(x,t)$ is a solution⁷ to problem (6) with control $c(x,t)$ on $t \geq 0$, $x \in \mathbb{R}$, and if the integral objective function (5) converges. A trajectory $(c^*(x,t), k^*(x,t))$, $t \geq 0$, $x \in \mathbb{R}$, is an optimal solution of problem (5) and (6) if it is admissible and it is optimal in the set of admissible trajectories, ie. for any admissible trajectory $(c(x,t), k(x,t))$, the value of the integral (5) is not greater than its value corresponding to $(c^*(x,t), k^*(x,t))$.

It is not very hard to see that the shape of preferences is crucial for the convergence of the integral (5) when space is **unbounded**. As we have mentioned in the introduction, Brito (2004) noticed this fact, and to get rid of it, he considered a different objective function, namely average utility function in space instead of our Benthamian type functional. We prefer to take another approach, and notably to

maintain the Benthamian functional as the natural extension of the original Ramsey model. We could have simplified our treatment by having space bounded but in such a case one would have to set boundary conditions, $\forall t \geq 0$, which is a highly arbitrary task. We finally prefer to address the pure case of infinite space and infinite time.

By considering that space is infinite just like time imposes a kind of symmetric handling of both to get admissible solutions. In particular, just like time discounting is needed to ensure the convergence of the integral objective function in the standard Ramsey model, we need a kind of *space discounting*. In our setting this space discounting is ensured by population density. Mathematically speaking an appropriate choice of $U(c, x)$ is to take it **rapidly decreasing** with respect to the second variable. That is, $U(c, x)$, for any fixed c , defined as,

$$\{U(c, \cdot) \in C(\mathbb{R}) \mid \forall m \in \mathcal{Z}_+, |x^m U(c, x)| \leq M_m, \forall x \in \mathbb{R}, M > 0\}.$$

A possible choice of $U(c, x)$ checking the above mentioned characteristic is $U(c, x) = V(c) \frac{\rho'}{2} e^{-\rho'|x|}$, where $V(c)$ is strictly increasing and concave in c , and $\rho' > 0$.

2.3 The Pontryagin conditions

The Pontryagin conditions corresponding to the control of a parabolic partial differential equation are rigorously studied in Raymond and Zidani (1998, 2000) with bounded open space and finite time, and reproduced in Brito (2004) for his particular problem. Using exactly the same kind of variational methods, we can establish the first-order conditions fitting our specific problem, which is given in the Appendix. These conditions are:

$$\left\{ \begin{array}{l} \frac{\partial q(x, t)}{\partial t} + \frac{\partial^2 q(x, t)}{\partial x^2} + q(x, t) (A(x, t) f'(k(x, t)) - \delta) = 0, \quad (x, t) \in \mathbb{R} \times [0, \infty), \\ q(x, t) = e^{-\rho t} \frac{\partial U(x, t)}{\partial c}, \quad (x, t) \in \mathbb{R} \times [0, \infty), \\ \lim_{t \rightarrow \infty} q(x, t) = 0, \quad \forall x \in \mathbb{R}, \\ \lim_{x \rightarrow \pm\infty} \frac{\partial q(x, t)}{\partial x} = 0, \quad \forall t \geq 0. \end{array} \right. \quad (7)$$

The first equation is the expected adjoint equation, with $q(x, t)$ playing the role of the co-state variable. As in the standard Ramsey model, the latter is equal to discounted marginal utility of consumption at the optimum, this should be true for every x and t in our spatial extension. The three last limit conditions are respectively the usual (time) transversality condition for infinite horizon discounted problems, and the two (space) transversality conditions implied by the asymptotic constraints on capital flow, $\lim_{x \rightarrow \pm\infty} \frac{\partial k(x, t)}{\partial x} = 0$. Notice the adjoint equation is also (non-surprisingly) a parabolic PDE. However in contrast to the state equation (6), which is of the Cauchy type, the adjoint equation has no initial value $q_0(x) = q(x, 0)$, but this is also a property of the adjoint equation in the standard non-spatial Ramsey model. Finally, one should mention that generally the above conditions are not only necessary, they are also sufficient under the typical concavity conditions like our conditions on the utility and production function across space. See for example Gozzi and Tessoro (1998). So that solving for optimal trajectories amounts in principle to solving the following system:

$$\left\{ \begin{array}{l} \frac{\partial k(x, t)}{\partial t} - \frac{\partial^2 k}{\partial x^2}(x, t) = A(x, t)f(k(x, t)) - c(x, t), \quad (x, t) \in \mathbb{R} \times [0, \infty), \\ \frac{\partial q(x, t)}{\partial t} + \frac{\partial^2 q(x, t)}{\partial x^2} = q(x, t) (\delta - A(x, t) f'(k(x, t))), \quad (x, t) \in \mathbb{R} \times [0, \infty), \\ k(x, 0) = k_0(x), \quad \forall x \in \mathbb{R}, \\ q(x, t) = e^{-\rho t} \frac{\partial U(x, t)}{\partial c}, \quad (x, t) \in \mathbb{R} \times [0, \infty), \\ \lim_{t \rightarrow \infty} q(x, t) = 0, \quad \forall x \in \mathbb{R}, \\ \lim_{x \rightarrow \pm\infty} \frac{\partial q(x, t)}{\partial x} = 0, \quad \forall t \in \mathbb{R}, \\ \lim_{x \rightarrow \pm\infty} \frac{\partial k(x, t)}{\partial x} = 0, \quad \forall t \in \mathbb{R}, \end{array} \right. \quad (8)$$

for given continuous $k_0(x)$. While establishing the existence of solutions to the corresponding problem in the standard Ramsey (also referred to as the Hamiltonian system or the Cass-Shell system) is far from obvious (see first proof in Gaines, 1976), the task is uncomparably harder with the space dimension. As we will see in the next section, there is a key difference with respect to the standard Ramsey model which makes our elementary spatial extension amazingly more complicated.

3 The existence and uniqueness problem

We shall start with a preliminary result, then clarify the point outlined just above. To this end we will introduce some new results on analytical solution of PDEs.

3.1 A preliminary result

Consider the general parabolic PDE in variable $u(x, t)$:

$$\frac{\partial u(x, t)}{\partial t} - \frac{\partial^2 u(x, t)}{\partial x^2} = G(u(x, t), z(x, t)), \quad (9)$$

where $G(\cdot)$ is any given continuous function, and $z(x, t)$ a forcing variable, with initial continuous function $u(x, 0) = u_0(x)$ given.

Theorem 1 requires the following assumption on growth for $x \rightarrow \pm\infty$ in order to ensure uniqueness:

(A3) For any given finite T , if $(x, t) \in \mathbb{R} \times (0, T]$, there exist constants $z_0 > 0$, $u_0 > 0$ and $b < \frac{1}{4T}$, such that, as $x \rightarrow \pm\infty$

$$0 < z(x, t) \leq z_0 e^{b|x^2|}, \quad 0 < u_0(x) \leq u_0 e^{b|x^2|}.$$

Notice that investment in any location x and at any time $t \in [0, T]$,

$$i(x, t) = A(x, t)f(k(x, t)) - \delta k(x, t) - c(x, t)$$

can be positive or negative. (A3) imposes that the “average accumulated” investment in the economy is nonnegative. Indeed, (A3) computes the average accumulated investment at location x and time t assuming that it follows a normal law of distribution with mean x and variation $\sqrt{t - \tau}$.

Theorem 1 *Let assumption (A3) hold and $z(x, t) \in C^{2,1}(\mathbb{R} \times (0, T))$. Then problem*

(9) has a unique solution $u \in C^{2,1}(\mathbb{R} \times (0, T])$, given by

$$\begin{aligned} u(x, t) &= \int_{\mathbb{R}} \Gamma(x - y, t) u_0(y) dy \\ &+ \int_0^t \int_{\mathbb{R}} \Gamma(x - y, t - \tau) [G(u(y, \tau), z(y, \tau))] dy d\tau. \end{aligned} \tag{10}$$

Moreover,

$$|u| \leq K e^{\beta|x|^2}, \text{ as } x \rightarrow \pm\infty,$$

where K is a positive constant, which depends only on z_0 , u_0 , T , and $\beta \leq \min\{b, \frac{1}{4T}\}$,

$$\Gamma(x, t) = \begin{cases} \frac{1}{(4\pi t)^{\frac{1}{2}}} e^{-\frac{x^2}{4t}}, & t > 0, \\ 0, & t < 0. \end{cases}$$

Furthermore if z, u_0 are bounded functions, then the above unique solution is also bounded.

Proof: See the appendix.

Notice that (10) is a kind of explicit representation of the solution paths of the typical parabolic PDE (9); it involves some ‘‘canonical’’ functions $\Gamma(x, t)$ just like the general characterization of the solutions to ordinary differential equation involve exponential terms. Let us keep this solution representation in mind from now on. It considerably helps clarifying the peculiarity of our problem.

For a backward parabolic equation with terminal condition,

$$\begin{cases} \mathcal{L}^* w = w_t + w_{xx} = H(w(x, t), h(x, t)), & x \in \mathbb{R}, \quad t \in [0, T), \\ w(x, T) = w_1(x), \text{ given,} & x \in \mathbb{R}. \end{cases}$$

let $v(x, t) = w(x, T - t)$, then we have similar results.

Corollary 1 Suppose $H(\cdot)$ is a continuous function, and for any given finite T , if $(x, t) \in \mathbb{R} \times (0, T]$, there exist some constants $h_1 > 0$, $w_1 > 0$ and $b_1 < \frac{1}{4T}$, such that, as $x \rightarrow \pm\infty$

$$0 < h(x, t) \leq h_1 e^{b_1 |x^2|}, \quad 0 < w_1(x) \leq w_1 e^{b_1 |x^2|}.$$

Then the solution to problem (3.1) at (x, t) is

$$\begin{aligned} w(x, t) &= \int_{\mathbb{R}} \Gamma(x - y, T - t) \phi(y) dy \\ &\quad - \int_t^T \int_{\mathbb{R}} \Gamma(x - y, T - \tau) H(w(y, T + t - \tau), h(y, T + t - \tau)) dy d\tau, \end{aligned}$$

More refinements on the explicit representations of the solutions to parabolic PDEs can be found in Wen and Zou (2000, 2002).

3.2 Why the control of parabolic PDEs hurts?

To make better the point, let us come back to the standard Ramsey model. The adjoint equation is:

$$q'(t) + q(t) (A(t) f'(k(t)) - \delta) = 0,$$

with obvious notations. Integrating the induced ordinary differential equation from 0 to t , one gets:

$$q(t) = q(0) e^{-\int_0^t (A(s) f'(k(s)) - \delta) ds}.$$

Obviously, $q(0)$ is *not known*; however, there exists a one-to-one relationship between $q(0)$ and $q(t)$ for a fixed capital trajectory. To any $q(0)$ is associated a single $q(t)$, and to any $q(t)$, one can only identify a unique compatible $q(0)$ value. Typically, $q(0)$ is uniquely determined by the transversality condition $\lim_{t \rightarrow \infty} q(t) = 0$, which establishes uniqueness of optimal trajectories in the Ramsey model. Unfortunately,

the same trick does not work in the spatial extension.

Consider our adjoint equation:

$$\frac{\partial q(x, t)}{\partial t} + \frac{\partial^2 q(x, t)}{\partial x^2} + q(x, t) (A(x, t) f'(k(x, t)) - \delta) = 0,$$

for a given capital and technology paths across time and space. By Theorem 1, if $q(x, 0) = q_0(x)$ and $A(x, t)f'(k(x, t))$ are bounded functions in the sense of Assumption 3, then the solution to this PDE can be represented as:

$$\begin{aligned} q(x, t) &= \int_{\mathbb{R}} \Gamma(x - y, t) q_0(y) dy \\ &\quad - \int_0^t \int_{\mathbb{R}} \Gamma(x - y, t - \tau) q(y, \tau) [A(y, \tau) f'(k(y, \tau)) - \delta] dy d\tau. \end{aligned}$$

Because $q_0(x)$ enters an integral, we lose the one-to-one relationship between the initial value- here $q_0(x)$ - and the whole trajectory $q(x, t)$. If $q_0(x)$ were known, then we can fix a unique path $q(x, t)$, but the reverse is evidently WRONG. Unfortunately, the transversality conditions will not be helpful to identify a unique $q_0(x)$ precisely because of the integral representation displayed in Theorem 1. In particular, the usual “economic” transversality condition $\lim_{t \rightarrow \infty} q(x, t) = 0$ will not help identifying the “good” $q_0(x)$, nor the remaining space transversality conditions can solve the problem, simply because the *unknown* $q_0(x)$ are inside the integrals and not outside. In the language of the PDE literature, our problem is called “ill-posed” (see definition in Hadamard J., 1923)⁸ : we cannot assure neither the existence, or the uniqueness of solution, nor the continuous dependence on known variables and initial-boundary conditions. Some “extra” information is needed to get rid of this. The other way to surmount it is to take linear utility, which induce a degenerescent adjoint equation. We try this strategy in the remaining sections of the paper.

4 The linear spatial Ramsey model

From now on, we will concentrate on the linear Ramsey model, the special case with linear utility. The objective function becomes:

$$\max_c \int_0^\infty \int_{\mathbb{R}} c(x, t) \psi(x) e^{-\rho t} dx dt,$$

and in order to compare with standard results in non-spatial settings, we shall add the usual irreversibility constraint, gross investment should be non-negative at any date and for any location, that is $i(x, t) = A(x, t)f(k(x, t)) - c(x, t) \geq 0$. Moreover, we assume that piece-wise $C^{2,1}$ function $A(x, t)$ checks conditions in Theorem 1 and 2. Further assumptions on the shape of preferences with respect to x are required:

(A4) $\psi(x) > 0$, $\rho\psi(x) - \psi''(x) > 0$ for all $x \in \mathbb{R}$ and $\int_{\mathbb{R}} \psi(x) = 1$.

As it will be clear in a few paragraphs, this condition is needed in our linear case to assure the positivity of the capital trajectory. The corresponding optimal control problem is:

$$\max_c \int_0^\infty \int_{\mathbb{R}} c(x, t) \psi(x) e^{-\rho t} dx dt \tag{11}$$

subject to:

$$\left\{ \begin{array}{l} \frac{\partial k(x, t)}{\partial t} - \frac{\partial^2 k(x, t)}{\partial x^2} = A(x, t)f(k(x, t)) - c(x, t) - \delta k(x, t), \quad (x, t) \in \mathbb{R} \times [0, \infty), \\ k(x, 0) = k_0(x) > 0, \quad x \in \mathbb{R}, \\ 0 \leq c(x, t) \leq A(x, t)f(k(x, t)), \quad x \in \mathbb{R}, t \geq 0, \\ \lim_{x \rightarrow \pm\infty} \frac{\partial k(x, t)}{\partial x} = 0 \quad t \geq 0. \end{array} \right. \quad (12)$$

In the sequel of this section, we consider the optimal control problem (11)-(12), the solution of which is given by Theorem 1 (when applied to systems of PDEs). In this linear case, $U(c, x) = c(x, t)\psi(x)$. Then from a direct calculation, we have

$$f'(k(x, t)) = \frac{(\rho + \delta)\psi(x) - \psi''(x)}{A(x, t)\psi(x)}, \quad (13)$$

and the corresponding capital (which is an **interior solution**) is

$$k^i(x, t) = (f')^{-1} \left(\frac{(\rho + \delta)\psi(x) - \psi''(x)}{A(x, t)\psi(x)} \right).$$

From (12), we have that

$$c(x, t) = A(x, t)f(k) - \delta k(x, t) + k_{xx}(x, t) - k_t(x, t) \quad (14)$$

which gives the dynamics of the economy starting from the initial condition $k_0(x)$ to the solution as (13). In the rest of this work, we consider a time independent technology, i.e. $A(x, t) = A(x)$. Then from (13), the interior solution for capital is also time independent.

The optimal consumption decision can lay in one of the following regimes:

$$c(x, t) = \begin{cases} 0, \\ A(x)f(k(x, t)), \\ \in (0, A(x)f(k(x, t))). \end{cases}$$

In the first case, consumption is zero and all the output is used for investment. In the second one there is no investment, all output is consumed. These are the two corner solutions for consumption. The third case covers the interior solution. The next sub-sections are devoted to study the optimal dynamics, starting from any corner regime. Particular attention will be paid to the conditions under which the economy moves from the corner to the interior regimes (per location), as it is traditional in the optimal control problems which are linear in the control variables. In order to compare with the standard case, we recall very briefly its main dynamic properties.

4.1 Recalling the linear Ramsey model without space

Consider a standard Ramsey model with linear utility function:

$$\max_c \int_0^{\infty} c(t)e^{-\rho t} dt,$$

subject to

$$\dot{k} = Af(k(t)) - \delta k(t) - c(t), \quad k(0) \text{ given},$$

and the irreversibility constraint, $0 \leq c(t) \leq Af(k(t))$. First order conditions

give the interior solution for k as

$$k^i = (f')^{-1} \left(\frac{\rho + \delta}{A} \right).$$

Not surprisingly, the interior solution in the non-spatial cases coincides with the interior solution of the spatial counterpart whence $\psi(x) = 1, \forall x$. Let us consider the two traditionally induced corner solution cases. Let us sketch the usual reasonings.

Case 1. $c = Af(k)$. The regime arises if initially $Af'(k) < \delta + \rho$. In such a case, the solution for capital accumulation along the regime is explicit and is given by $k(t) = k(0)e^{-\delta t}$, which converges to zero, as t goes to infinity. Hence starting from above, the capital path will reach the interior solution in a finite time, provided the rate of capital depreciation is nonzero.

Case 2. $c = 0$. The regime arises if initially $Af'(k) > \delta + \rho$. Solving the law of motion of capital with $c = 0$, one gets:

$$k(t) = k(0)e^{\int_0^t \left[\frac{Af(k(s)) - \delta k(s)}{k(s)} \right] ds}.$$

Obviously, whenever $Af(k) - \delta k > 0$ (positive net savings), the solution path is increasing. But if $Af'(k(0)) > \delta + \rho$ or equivalently $Af'(k(0)) - \delta > \rho > 0$, then savings per capita net of depreciation (net savings hereafter), $Af(k(t)) - \delta k(t)$, will be not only positive but increasing at the beginning of the corner regime if $Af(k(0)) - \delta k(0) > 0$. Therefore, the capital trajectory will start increasing provided $Af(k(0)) - \delta k(0) > 0$. However, the concavity of the production function will induce a decreasing pattern of the marginal productivity of capital, so that at a finite date $T > 0$, the interior solution is reached, that it is $Af'(k(T)) - \delta = \rho$. Note that the capital path cannot be "stuck" at a stationary solution of the corresponding corner regime before reaching the interior solution. Such a stationary solution,

k^s , checks: $\frac{Af(k^s)}{k^s} = \delta > Af'(k^s)$ by concavity. Since the interior solution checks $Af'(k^i) = \delta + \rho$, we have $f'(k^i) > f'(k^s)$, thus $k^i < k^s$ again by concavity. In the other case, $Af(k(0)) - \delta k(0) < 0$, and capital goes down at the beginning of the corner regime, which leads to $Af'(k(t)) - \delta < \rho$ by the same concavity argument. That is a contradiction to the assumption, therefore in this case, $c = 0$ is not a solution.

We are now ready to get to the spatial case. We shall see how the space dimension enriches the properties mentioned just above.

4.2 The dynamics of the spatial linear Ramsey model

We first introduce some preliminary important definitions, which will be interpreted in economic terms hereafter. Precisely, we define the steady state (or stationary) solutions and the upper and lower solutions of the steady state problems. The latter concept is extremely useful in the literature of PDEs.

The steady state of problem (11)-(12) is defined as:

$$(P_s) \begin{cases} -\frac{\partial^2 k(x)}{\partial x^2} = A(x)f(k(x)) - c(x) - \delta k(x), & x \in \mathbb{R}, \\ \lim_{x \rightarrow \pm\infty} \frac{\partial k(x)}{\partial x} = 0. \end{cases}$$

Now we recall the mathematical definition of upper and lower solutions to P_s .

Definition 2 *A function $k^u(x)$ is an upper solution of P_s if it satisfies that*

$$-\frac{\partial^2 k(x)}{\partial x^2} \geq A(x)f(k(x)) - c(x) - \delta k(x), \quad x \in \mathbb{R}.$$

Similarly, we say that a function $k_l(x, t)$ is a lower solution of problem P_s if the inequality above is verified with sign \leq .

Notice that the upper and lower solutions can be properly interpreted in economic terms. In order to compare with the non-spatial Ramsey model, let us use the same terminology. Notice that the right hand side of the inequality could be interpreted as the net savings at location x , while the left hand side measures capital flows at x . Integrating the inequality between two locations a and b , say $a < b$, one can infer that along an upper solution, net savings in the region $[a, b]$ are lower than or equal to the amount of capital flowing out of this region. Consequently, the upper solution concept should recover the case of non-increasing patterns of capital accumulations. Lower solutions fit just the opposite case.

With this proviso in mind, we next study the convergence from below and from above the interior solution, assuming that *all* locations start either below or above their interior regime. This case is the simplest one and it already allows to capture the main idea of the paper, that is, the spatial dynamics induced by perfect capital mobility enrich considerably the asymptotic behavior of the Ramsey model⁹. We shall study the case where the initial capital stock in the whole space is typically lower (resp. higher) than the interior value, which corresponds to the case of a “too” high (resp. low) return to capital.

4.2.1 High marginal productivity case

Suppose that at $t = 0$,

$$f'(k_0(x)) > \frac{(\rho + \delta)\psi(x) - \psi''(x)}{A(x)\psi(x)}, \quad (15)$$

and that

$$-(k_0(x))_{xx} \leq A(x)f(k_0(x)) - \delta k_0(x), \quad \forall x \in \mathbb{R}. \quad (16)$$

That is, initially the marginal productivity of capital is higher than the marginal

cost. As a result, it is optimal to keep on investing until the capital stock satisfies the optimal rule (13) if possible, and $c(x) = 0, \forall x \in \mathbb{R}$. By assumption (A1), $f''(k) < 0$, so in this case

$$k_0(x) < k^i(x), \quad \forall x \in \mathbb{R}.$$

Hence the dynamics of the state equation are

$$\left\{ \begin{array}{l} \frac{\partial k(x, t)}{\partial t} - \frac{\partial^2 k(x, t)}{\partial x^2} = A(x, t)f(k(x, t)) - \delta k(x, t), \quad (x, t) \in \mathbb{R} \times [0, \infty), \\ k(x, 0) = k_0(x) > 0, \quad x \in \mathbb{R}, \\ \lim_{x \rightarrow \pm\infty} \frac{\partial k(x, t)}{\partial x} = 0, \quad \forall t \geq 0. \end{array} \right.$$

Condition (16) actually ensures that $k_0(x)$ is a *lower solution* of the stationary equation,

$$-k(x)_{xx} = A(x)f(k(x)) - \delta k(x), \quad \forall x \in \mathbb{R}. \quad (17)$$

The dynamic properties of the model heavily rely on condition (16), as the following theorem shows.

Theorem 2 *Suppose (A1), (A2) hold and $A(\cdot)$ is a bounded function. Moreover we assume that $Af'(k) \geq \delta$ for any feasible function k .*

(a) *If k_0 is a lower solution of P_s , then the solution path for capital is nondecreasing in t for any location along the corner regime, that is*

$$k_0(x) \leq k(x, t), \quad \forall x \in \mathbb{R}, \quad \forall t \geq 0.$$

Further, if k_0 is not a solution to (17), then $k(x, t)$ is strictly increasing in t .

(b) *If k_0 is an upper solution of P_s , then the solution the solution path for capital*

is nonincreasing in t for any location along the corner regime, that is

$$k_0(x) \geq k(x, t), \quad \forall x \in \mathbb{R}, \quad \forall t \geq 0.$$

Further, if k_0 is not a solution to (17), then $k(x, t)$ is strictly decreasing in t .

Proof. See the appendix.

Theorem 2 features the different dynamic outcomes, and should be compared with the typical outcomes in the non-spatial counterpart (our Section 4.1). Starting below the interior solution, the economy may or may not reach the interior solution. If $k_0(x)$ is a lower solution, then by Theorem 2-(a), the capital patterns are non-decreasing. In the special case $k(x, t) = k_0(x) = \bar{k}(x)$, $\forall t$. Hence, $k(x, t) < k^i(x)$ forever. However, if $k_0(x)$ checks (16) and is not a solution to (17), then the capital paths will be strictly increasing at any location, and may converge to the interior regime at a finite time T_1 . Of course, convergence is not guaranteed: increasing patterns of capital may be “stuck” at a solution of (17) before convergence. Yet starting at a lower solution is a possible way to get to the interior solution. This is not surprising at all given our economic interpretation of the lower solution concept, which features the cases where net savings are larger than or equal to capital flowing out of any location x . If $k_0(x)$ checks (16) with strict inequality, then net savings are strictly larger than capital outflows everywhere, and capital should grow, possibly (not surely) reaching the interior solution after a while. The reverse happens when the initial condition $k_0(x)$ is an upper solution of P_s . In such a case, convergence to the interior solution is impossible.

So far, we have exhibited a kind of generalization of the standard non-spatial linear Ramsey model properties. In the benchmark case (see Section 4.1), when the economy starts with regime $c = 0$, it converges to the interior solution if and only if net savings (with $c = 0$) are strictly positive initially. With space, this property

may arise under the condition that initially net savings (with $c = 0$) at any location exceed capital outflows. Nonetheless, a huge difference with the non-spatial case emerges here: even if the initial net savings are strictly positive, that it is even if the initial capital profile is a lower solution, there is no guarantee that the resulting increasing patterns reach the interior solution. As mentioned just above, this is due to the fact that these capital trajectories may be “stuck” at some stationary solution of the corresponding corner regime. Such a possibility does not exist in the non-spatial case.

Any way, this is good news: of course, the spatial model has much trickier properties, much richer dynamics thanks to the capital mobility engine. We shall address the remaining issues numerically in the last section. In particular, we shall exhibit cases in which capital trajectories are increasing (because the initial capital profile is a lower solution) but do not get to the interior solution. Before getting to this numerical section, we examine the case of an initially “too” low marginal productivity of capital, giving rise to the other corner regime.

4.2.2 Low marginal productivity case

Suppose initially that $k_0(x)$ satisfies

$$f'(k_0(x)) < \frac{(\rho + \delta)\psi(x) - \psi''(x)}{A(x)\psi(x)}.$$

Productivity in this economy is too low, the marginal cost is initially higher than marginal productivity. As a result, the economy stops investing at any location and consume all the output of the location until (13) holds (if possible): $c(x, t) = A(x)f(k(x, t))$. By the concavity of the production function, we have that actually $k_0(x) > k^i(x)$, $\forall x \in \mathbb{R}$.

Then, the capital dynamics are described by:

$$\left\{ \begin{array}{l} \frac{\partial k(x, t)}{\partial t} - \frac{\partial^2 k(x, t)}{\partial x^2} = -\delta k(x, t), \quad (x, t) \in \mathbb{R} \times [0, \infty), \\ k(x, 0) = k_0(x) > 0, \quad x \in \mathbb{R}, \\ \lim_{x \rightarrow \pm\infty} \frac{\partial k(x, t)}{\partial x} = 0, \quad \forall t \geq 0. \end{array} \right. \quad (18)$$

Before stating the main convergence theorem, we first study a special case, with no capital depreciation rate, $\delta = 0$. We have the following result.

Theorem 3 *Suppose (A1), (A2) and $A(\cdot)$ is a bounded function. Furthermore, let $\delta = 0$.*

(a) *Then the solution path for capital along the corner regime $c(x, t) = A(x)f(k(x, t))$, is non-increasing and*

$$k_0(x) \geq k(x, t), \quad \forall x \in \mathbb{R}, \quad \forall t \geq 0.$$

(b) *If $k_0(x)$ is an upper solution but not a steady state solution, then $k(x, t)$ is strictly decreasing in t .*

(c) *If $k_0(x)$ is a lower but not a steady state solution, then $k(x, t)$ is strictly increasing in t , and convergence to the interior solution is impossible.*

Proof: This theorem can be proved following the same reasoning as in the proof of Theorem 2.

Strictly speaking, Theorem 3 is not surprising: once removed capital depreciation, the unique engine of capital stock variation is capital mobility. In the non-spatial case and in such a corner situation, the state equation degenerates into $\dot{k} = 0$, therefore inducing that the capital trajectory will stick to the initial condition $k(0)$

forever. In the spatial case with capital mobility, the capital stock can still change over time, and the outcome depends, as in the initial high marginal productivity case, on whether initial net savings are lower or larger than capital outflows.

What happens if capital depreciation is allowed? With nonzero capital depreciation, things are quite different. Let $u(x, t) = k(x, t)e^{\delta t}$, after simple calculations, we obtain

$$\begin{cases} u_t - u_{xx} = (k_t - k_{xx})e^{\delta t} + \delta k e^{\delta t} = 0, \\ u(x, 0) = k_0(x). \end{cases}$$

So the theoretical part of the solution will not change. However notice that $k(x, t) = u(x, t)e^{-\delta t}$ is the product of two terms: a bounded term $u(x, t)$ (by Theorem 1 with function $G(\cdot)$ identically zero) and a second term converging to zero as t goes to infinity.

Furthermore, the unique solution to the steady state of (18) is $k(x) \equiv 0$. This implies that the solution trajectory will not be “stuck” at a steady state solution in its decreasing path towards the interior solution. Then, there exists a point in time, t_1 , such that, $k(x, t_1)$ equals the interior solution. At this point, consumption changes to its interior value. This means that from t_1 onwards, the solution equals the interior solution, i.e. **capital converges** to the interior solution.

To conclude the above analysis, we write it as the main convergence result.

Theorem 4 *Suppose (A1), (A2) and $A(\cdot)$ is a bounded function. In the case of low marginal productivity, for any initial capital distribution, the existence of non-zero depreciation ensures convergence to the interior solution in finite time.*

Therefore, in such a corner case, capital depreciation is stronger than capital mobility for all initial capital profiles, which is similar to the non-spatial Ramsey set-up. Of course, this property does not hold in the other corner regime: when

the initial marginal productivity of capital is high, investment is no longer zero, and thus the capital stock moves pushed by two engines: capital mobility across location and nonzero investment per location. The conjunction of these two engines may dominate the capital depreciation engine as featured in Theorem 2 (a).

5 Numerical experiments

We would like to illustrate the richness of this model with respect to the non-spatial Ramsey model. We provide two examples of initial distributions of capital in high marginal productivity economies that do not attain the interior solution.

Table 1 presents the parameter values that describe our scenario. The density function $\phi(\cdot)$ has been adapted so that population size is equal to 1 in the simulation space $[-100, 100]$.

$f(k(x, t)) = k(x, t)^\alpha$	$\alpha = 1/3$
$\psi(x) = ae^{-\phi x }$	$\phi = 0.5, a = 0.25$
$\delta = 0.3$	
$\rho = 0.03$	
$A = 10$	

Table 1: Functional specifications and parameter values for the numerical exercise

With these parameter values, the interior solution is spatially homogenous:

$$k^i(x) = (f')^{-1} \left(\frac{\rho\psi(x) - \psi''(x)}{A\psi(x)} \right) = \left(\frac{A\alpha}{\rho + \delta - \phi^2} \right)^{\frac{1}{1-\alpha}} \simeq 268.96.$$

Though the steady state problem P_s with $c(x) = 0$ does not have a unique solution, it has a unique non-trivial spatially homogenous solution:

$$k_s(x) = \left(\frac{A}{\delta} \right)^{\frac{1}{1-\alpha}} \simeq 192.45.$$

It is very important for the numerical experiments to notice that $k_s(x) < k_i(x)$, $\forall x \in \mathbb{R}$.

Example 1:

We would like to illustrate the case of an economy initially endowed with a physical capital distribution k_0 which lies below the interior solution and it is a lower solution to P_s . The solution trajectory to this problem does not converge to the interior solution but gets “stuck” at a steady state solution. Let k_0 be:

$$k_0(x) = \begin{cases} 1, & x \leq 1, \\ x, & 1 < x \leq 5, \\ 5, & x > 5. \end{cases}$$

One can readily see in the simulation graph that the solution is effectively increasing (Theorem 2 (a)) and that it converges to the spatially homogenous steady state solution ($k_s(x) = 192.45$), never reaching the interior solution (see figure 1).

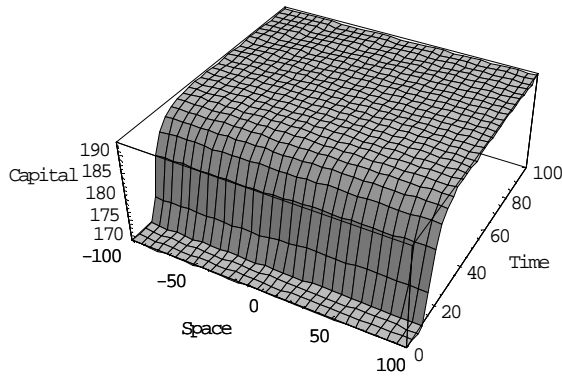

Figure 1: $k_0 < k_s < k_i$, k_0 lower solution

Example 2:

On the other hand, we study in this example a high marginal productivity economy which is endowed with an initial distribution above the steady state and very close to the interior solution:

$$k_0(x) = 260.$$

Moreover, the initial distribution is an upper solution to P_s , with $k_s < k_0 < k_i$. According to Theorem 2 (b), the solution trajectory is decreasing. What can be checked with the numerical exercise is that the spatially homogenous steady state solution is attained (see figure 2).

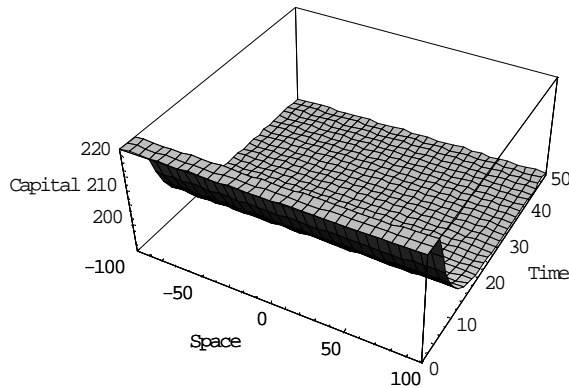

Figure 2: $k_s < k_0 < k_i$, k_0 upper solution

Notice that our results heavily rely on the parameter set. Had we chosen a population density function as $\phi(x) = 0.125e^{-0.25|x|}$, we would have $k_i < k_s$. In this case, any economy endowed with an initial distribution of capital that is a lower solution to P_s and $k_0 < k_i$, converges to the interior solution.

6 Conclusion

In this paper, we have tried to formulate a prototype of spatial Ramsey model with continuous space. In particular, we have departed from the non-Benthamian Ramsey model of Brito (2004) by introducing spatial discounting. We have studied the induced dynamic problem and shown why the optimal control of the resulting parabolic partial differential equations finally gives rise to an ill-posed problem. Our

detailed analysis of the linear Ramsey model, which is clearly a way to escape from the ill-posed problem, has the advantage to highlight the tremendous complexity of spatial dynamics even in this linear case.

Two main conclusions can be drawn from our work: first of all, the spatial dimension in a Ramsey framework clearly “adds something” to the story of the neo-classical growth models, with much less trivial asymptotic results and convergence properties, and more case studies, depending on the relative strength of several engines, among them the spatial “guest star”: capital mobility. Second, there is still a tremendous effort to do in order to understand completely what is going on in these models. In particular, we should try to reach a much better understanding of the structure of the stationary solutions. In this respect, developing new analytical and/or computational tools sounds as a minimal prior condition. These technical tasks should be undertaken before tackling more interesting economic extensions of the model, notably migrations.

7 Appendix

7.1 Proof of (4)

Let us suppose that

$$\frac{\partial k(x, t)}{\partial t} - \frac{\partial^2 k(x, t)}{\partial x^2} \neq A(x, t)f(k(x, t)) - \delta k(x, t) + c(x, t), \quad \forall(x, t),$$

in some interval $[a, b] \subset X$ with

$$\int_a^b \left(\frac{\partial k(x, t)}{\partial t} - \frac{\partial^2 k(x, t)}{\partial x^2} - A(x, t)f(k(x, t)) - \delta k(x, t) + c(x, t) \right) \psi(x) dx = 0.$$

Putting these two conditions together, it implies that there exists at least a subinterval $[a_1, b_1] \subset [a, b]$ such that

$$\int_{a_1}^{b_1} \left(\frac{\partial k(x, t)}{\partial t} - \frac{\partial^2 k(x, t)}{\partial x^2} - A(x, t)f(k(x, t)) - \delta k(x, t) + c(x, t) \right) \psi(x) dx > 0. \quad (19)$$

However, we know that

$$\int_X \left(\frac{\partial k(x, t)}{\partial t} - \frac{\partial^2 k(x, t)}{\partial x^2} - A(x, t)f(k(x, t)) - \delta k(x, t) + c(x, t) \right) \psi(x) dx = 0,$$

for any closed region X . Hence, in particular it is also true for $[a_1, b_1]$, which is in contradiction with (19) and proves that $\frac{\partial k(x, t)}{\partial t} - \frac{\partial^2 k(x, t)}{\partial x^2} = A(x, t)f(k(x, t)) - \delta k(x, t) + c(x, t), \quad \forall(x, t)$. \diamond

7.2 Obtain first order condition

Suppose that (c^*, k^*) is one optimal solution of the optimal control problem and consider the perturbed path (c, k) , such that, for any arbitrary functions p, h , and

$\epsilon > 0$,

$$p, h : \mathbb{R} \times \mathbb{R}^+ \rightarrow \mathbb{R},$$

and

$$c = c^* + \epsilon h, \quad k = k^* + \epsilon p.$$

The corresponding value function V is defined as

$$V = \int_0^\infty \int_{\mathbb{R}} U(c(x, t), x) e^{-\rho t} dt dx$$

$$- \int_0^\infty \int_{\mathbb{R}} q(x, t) \left(\frac{\partial k(x, t)}{\partial t} - \frac{\partial^2 k}{\partial x^2}(x, t) - A(x, t) f(k(x, t)) + c(x, t) \right) dx dt.$$

As usual, to achieve the maximum of V , the first order condition $\frac{\partial V}{\partial \epsilon} = 0$ should hold.

Let us study first:

$$\int_0^\infty \int_{\mathbb{R}} q(x, t) \frac{\partial k(x, t)}{\partial t} dx dt, \quad \text{and} \quad \int_0^\infty \int_{\mathbb{R}} q(x, t) \frac{\partial^2 k(x, t)}{\partial x^2} dx dt.$$

Integration by parts yields

$$\int_0^\infty \int_{\mathbb{R}} q(x, t) \frac{\partial k(x, t)}{\partial t} dx dt = \int_{\mathbb{R}} k q|_0^\infty dx - \int_0^\infty \int_{\mathbb{R}} k \frac{\partial q}{\partial t} dx dt,$$

and

$$\int_0^\infty \int_{\mathbb{R}} q(x, t) \frac{\partial^2 k(x, t)}{\partial x^2} dx dt = \int_0^\infty q \frac{\partial k}{\partial x} \Big|_{-\infty}^\infty dt - \int_0^\infty \int_{\mathbb{R}} \frac{\partial q}{\partial x} \frac{\partial k}{\partial x} dx dt$$

$$= \int_0^\infty q \frac{\partial k}{\partial x} \Big|_{-\infty}^\infty dt - \int_0^\infty k \frac{\partial q}{\partial x} \Big|_{-\infty}^\infty dt + \int_0^\infty \int_{\mathbb{R}} k \frac{\partial^2 q}{\partial x^2} dx dt.$$

As a consequence,

$$\frac{\partial V}{\partial \epsilon} = \int_0^\infty \int_{\mathbb{R}} (\psi(x) e^{-\rho t} - q) h dx dt -$$

$$\begin{aligned}
& - \int_0^\infty \int_{\mathbb{R}} p(x, t) \left(-\frac{\partial q}{\partial t} - \frac{\partial^2 q}{\partial x^2} \right) dx dt - \int_{\mathbb{R}} p(x, t) q(x, t) \Big|_0^\infty dx + \\
& - \int_0^\infty p \frac{\partial q}{\partial x} \Big|_{-\infty}^\infty + \int_0^\infty \int_{\mathbb{R}} qpAf'(k(x, t)) dx dt.
\end{aligned}$$

Then, $\frac{\partial V}{\partial \epsilon} = 0$, provided

$$q(x, t) = e^{-\rho t} U_1'(c, x),$$

and for admissible $c(x, t)$ and $k(x, t)$ in $C^{2,1}(\mathbb{R} \times [0, \infty))$,

$$(Q) \begin{cases} \frac{\partial q}{\partial t} + \frac{\partial^2 q}{\partial x^2} + q(x, t) Af'(k(x, t)) = 0, \\ q(x, t) = e^{-\rho t} U_1'(c, x), \\ \lim_{t \rightarrow \infty} q(x, t) = 0, \\ \lim_{x \rightarrow \infty} \frac{\partial q}{\partial x} = \lim_{x \rightarrow -\infty} \frac{\partial q}{\partial x} = 0. \quad \diamond \end{cases}$$

7.3 Proof of Theorem 1

(1) Let $(x, t) \in \mathbb{R} \times (0, T]$. Define a sequence $\{u^{(n)}\}$, ($n \geq 1$) successively from the iteration process

$$\begin{cases} \mathcal{L}u^{(n)} = u_t^{(n)} - u_{xx}^{(n)} = G(u^{(n-1)}(x, t), z(x, t)), & \text{in } \mathbb{R} \times (0, T], \\ u^{(n)}(x, 0) = u_0(x), & \text{in } \mathbb{R}, \end{cases}$$

with $u^{(0)}(x, t) = u_0(x)$ and $G(u^{(n-1)}(x, t), z(x, t))$ is some known function of x and t . If assumptions (A1)- (A3) hold, then this sequence is well defined. Due to Theorem 7.1.1 in Pao (1992), a unique solution sequence $\{u^{(n)}\} \in C^{2,1}(\mathbb{R} \times (0, T])$ exists and

it is given by

$$\begin{aligned}
u^{(n)}(x, t) &= \int_{\mathbb{R}} \Gamma(x - y, t) u_0(y) dy \\
&+ \int_0^t \int_{\mathbb{R}} \Gamma(x - y, t - \tau) [G(u^{(n-1)}(y, \tau), z(y, \tau))] dy d\tau,
\end{aligned} \tag{20}$$

where $\Gamma(x, t)$ is the fundamental solution to the parabolic operator \mathcal{L} :

$$\Gamma(x, t) = \begin{cases} \frac{1}{(4\pi t)^{\frac{1}{2}}} e^{-\frac{x^2}{4t}}, & t > 0, \\ 0, & t < 0. \end{cases}$$

See for example, pages 261–265, in Ladyzenskaja, Solonnikov and Ural'ceva (1968) or page 14 in Frideman (1983). Furthermore, there exists some positive constants M and β such that the solution satisfies the growth condition for each n

$$|u^{(n)}| \leq M e^{\rho|x|^2}, \text{ as } x \rightarrow \pm\infty,$$

Notice that the sequence starting from u_0 , and then M does not depend on n . Hence, we obtain that for $t \in (0, T]$, for any x , there exist an estimate for the solution

$$|u^{(n)}| \leq M' e^{\rho'|x|^2},$$

for some positive constants M' and ρ' .

Then there is a subsequence, $u^{(n_j)}$, which converges to a function $\tilde{u} \in C^{2,1}(\mathbb{R} \times (0, T])$, and satisfies

$$|\tilde{u}| \leq M'' e^{\rho''|x|^2}, \quad \forall x \in \mathbb{R},$$

for some positive constants M'' and ρ'' .

Due to the uniqueness of the solution to the linear equation, one can prove that

the whole sequence converges to \tilde{u} . In (20), taking the limit when $n \rightarrow \infty$ on both sides, we obtain that

$$\begin{aligned}\tilde{u}(x, t) &= \int_{\mathbb{R}} \Gamma(x - y, t) u_0(y) dy \\ &+ \int_0^t \int_{\mathbb{R}} \Gamma(x - y, t - \tau) [G(\tilde{u}(y, \tau), z(y, \tau))] dy d\tau.\end{aligned}$$

By the fundamental solution result, \tilde{u} is the solution to problem (9) for $(x, t) \in \mathbb{R} \times (0, T]$ and it satisfies the growth condition

$$0 < u \leq K e^{\beta|x|^2}, \text{ as } x \in \mathbb{R},$$

for some constant K and $\beta = \rho''$. \diamond

7.4 Proof of Theorem 2.

(a) Let $w(x, t) = k(x, t) - k_0(x)$, then $w_t(x, t) = k_t(x, t)$ and $w_{xx}(x, t) = k_{xx}(x, t) - (k_0(x))_{xx}$. The state equation

$$\begin{aligned}w_t(x, t) - w_{xx}(x, t) &= k_t(x, t) - k_{xx}(x, t) + (k_0(x))_{xx} \geq \\ &\geq A(x)f(k(x, t)) - \delta k(x, t) - A(x)f(k_0(x)) + \delta k_0(x) = \\ &= A(x)f'(\eta(x, t))(k(x, t) - k_0(x)) - \delta k(x, t) + \delta k_0(x) = \\ &= (A(x)f'(\eta(x, t)) - \delta)(k(x, t) - k_0(x)),\end{aligned}$$

where $\eta(x, t)$ is a function between $k(x, t)$ and $k_0(x)$, and the inequality comes from assuming that $k_0(x)$ checks (16). Besides, $w(x, 0) = v(x, 0) - k_0(x) = 0$.

Notice that we can write it as:

$$w_t(x, t) - w_{xx}(x, t) \geq (A(x)f'(\eta(x, t)) - \delta)w(x, t), \quad (21)$$

where the right hand side is linear in $w(., .)$ and $A(x)f'(\eta(x, t)) - \delta$ is bounded. We can therefore apply Lemma 7.2.1 in Pao since $w_0(x) = 0$. This implies that

$$w(x, t) \geq 0, \quad \forall t \geq 0, \quad \forall x \in \mathbb{R}.$$

As a result, $k(x, t) \geq k_0(x)$. More precisely, $k(x, t) > k_0(x)$ unless $k(x, t) \equiv k_0(x)$.

Now, we prove that $k(x, t)$ is nondecreasing in t . For any fixed constant $\rho > 0$, denote $k_\rho(x, t) = k(x, t + \rho)$ consider function $v(x, t) = k(x, t + \rho) - k(x, t)$. It is easy to check that $v(x, t)$ satisfies

$$\begin{aligned} v_t(x, t) - v_{xx}(x, t) &= A(x)f(k_\rho(x, t)) - \delta k_\rho(x, t) - A(x)f(k(x, t)) + \delta k(x, t) = \\ &= (A(x)f'(\zeta(x, t)) - \delta)v(x, t), \quad \forall t \geq 0, \quad \forall x \in \mathbb{R}, \end{aligned}$$

and

$$v(x, 0) = k(x, \rho) - k_0(x) \geq 0, \quad \forall x \in \mathbb{R},$$

where ζ lays between k_ρ and k , and $v(x, 0) \geq 0$ following the previous result.

Again by a comparison theorem for linear parabolic equations and the fact that v is bounded as $|x| \rightarrow \infty$:

$$v(x, t) \geq 0, \quad \forall t \geq 0, \quad \forall x \in \mathbb{R}.$$

That is, for any constant ρ :

$$k(x, t + \rho) \geq k(x, t), \quad \forall t \geq 0, \quad \forall x \in \mathbb{R},$$

so that $k(x, t)$ is an increasing function.

(b) We obtain the results using the same argument as in (a), putting $w(x, t) = k_0(x) - k(x, t)$. \diamond

Notes

¹Depreciation rate of capital is homogenous in time t , space x and capital level k .

²We could assume that there exist institutional barriers to capital flows (see Ten Raa, 1986, and Puu, 1982). If we assume that these barriers are independent of capital k and consumption c , we obtain a linear equation with coefficients in front of the Laplacean operator. After some affine transformations, results in section 2.2 would apply to this problem. Otherwise, if the barriers are functions of k and/or c , we face *nonlinear problems*, which are not considered in this work.

³ If we consider transportation costs in the form of delays, then we would obtain a *differential-difference* problem. These problems are difficult to handle. Therefore, we could consider a transportation cost proportional to output (the iceberg transportation cost). In this case results in section 2.2 apply. In a more general case with space velocity, we would have to deal with a non-local problem which is out of the scope of this paper.

⁴ Equation (6.3.13), Page159, Issard and Liossatos (1979) obtain the same law of motion of capital by using a slightly different approach in a finite continuous space and finite time space.

⁵By "without capital flow" we mean that $\lim_{x \rightarrow \pm\infty} \frac{\partial k(x, t)}{\partial x} = a$, where a is a constant. With a simple transformation and without loss of generality, we can assume $a = 0$. In this case, there is no surplus after consumption, so there is no trade. This is called the Neumann's problem. Equivalently, we can impose the Dirichlet condition, that is, $\lim_{x \rightarrow \pm\infty} k(x, t) = b(t)$. It states that when a household is far from the economic center, its stock of capital does not depend on trade. Except for the Pontryagin conditions, results with either assumptions are not essentially different.

⁶ Function space $C^{2,1}(\mathbb{R} \times [0, \infty))$ is defined a class of functions which are second order continuously differentiable with respect to its variable and first order continuously differentiable with its second variable.

⁷A solution to problem (6) in $C^{2,1}(\mathbb{R} \times [0, \infty))$ is called classic solution.

⁸See also Page 7, Evans (1998) for "well-posed" definition.

⁹The working paper version of this paper, available upon request, considers the more complicated case where space is partitioned into two half-spaces, one above the corresponding interior regime and the other below. Such an exercise does not bring any further economic value-added with respect to the simple and transparent cases treated in this version of the paper.

References

- Beckman, M. (1952), *A continuous model of transportation*, *Econometrica* 20, 643-660.
- Brito P.(2004), *The dynamics of distribution in a spatially heterogeneous world*, working papers, Department of Economics, ISEG, WP13/2004/DE/UECE..
- Bandle C., Pozio M. A. and Tesei A. (1987), *The asymptotic behavior of the solutions of degenerate parabolic equations*, *Trans. Amer. Math. Soc.*, Vol 303, (2), 487–501.
- Clark, C. (1951), “Urban Population Densities”, *Journal of the Royal Statistical Society, Series A*, Vol. 114, 490–496.
- De Mottoni P., Schiaffino A. and Tesei A.(1984), *Attractivity properties of non-negative solutions for a class of nonlinear degenerate parabolic problems*, *Ann. Mat. Pura. Appl.*, Vol 136, 35–48.
- Friedman A. (1983), *Partial Differential equations of parabolic type*, Malabar Fla. Kriger.
- Fujita, M. and JF. Thisse (2002), *Economics of agglomeration*. Cambridge University Press.
- Fujita, M., P. Krugman and A. Venables (1999), *The spatial economy. Cities, regions and international trade*. MIT Press.
- Gaines, R. (1976), *Existence of solutions to Hamiltonian dynamical systems of optimal growth*, *Journal of Economic Theory* 12, 114-130.
- Galaktionov V. A. And Vazquez J.(1995), *Necessary and sufficient conditions for complete blow-up and extinction for one-dimensional quasilinear heat equations*, *Arch. Rational Mech. Anal.* 129 , 225–244.

- Gollier Ch., *The economics of risk and time*, MIT Press, 2001.
- Golub G.H. and Ortega J.M. (1992), *Scientific Computing and Differential Equations. An Introduction to Numerical Methods*. Academic Press, Inc.
- Gozzi F. and Tessitore M. E.(1998), *Optimal conditions for dirichlet boundary control problems of parabolic type*, J. Mathematical Systems, Estimation and control, complete electronic version, Jan., code 08113.
- Hadamard J., (1923), *Lectures on the Cauchy Problem in Linear Partial Differential Equations*. Yale University Press.
- Hofbauer J. and P.L. Simon (2001), *An existence theorem for parabolic equations on \mathbb{R}^N with discontinuous nonlinearity*, E. J. Qualitative Theory of Diff. Equ. 8, 1-9.
- Isard, W. and P. Liossatos (1979), *Spatial Dynamics and Optimal Space-time Development*, North-Holland Publishing Company.
- Krugman, P. (1991), *Increasing returns and economic geography*, Journal of Political Economy 99, 483-499.
- Krugman, P. (1993), *On the number and location of cities*, European Economic Review 37, 293-298.
- Krugman, P. (1996), *The self-organizing economy, Appendix: a central place model*, Blackwell Press.
- Ladyzhenskaja O. A., Solonnikov V. A. and Ural'ceva N. N.(1968), *Linear and quasilinear equations of parabolic type*, Amer. Math. Soc. Providence, RI.
- Lenhart S. M. and Yong J. (1992), *Optimal control for degenerate parabolic equations with logistic growth*, preprint of Institute for mathematics and its application, University of Minnesota, USA, 1064.

- Lions J. L.(1971), *Optimal control of systems governed by partial differential equations* , Springer-Verlag, Berlin, New York.
- Mossay, P. (2003), *Increasing returns and heterogeneity in a spatial economy*, Regional Science and Urban Economics 33, 419-444.
- Pao C.V. (1992), *Nonlinear Parabolic and Elliptic Equations*, Plenum Press, New York.
- Puu, T. (1982), *Outline of a trade cycle model in continuous space and time*, Geographical Analysis 14, 1–9.
- Raymond J.P. and Zidani H.(1998), *Pontryagin's principle for state-constrained control problems governed by parabolic equations with unbounded controls*, SIAM J. Control Optim., vol 36 (6), 1853–1879.
- Raymond J.P. and Zidani H.(2000), *Time optimal problems with Boundary controls*, Diff. and Integral Equations, Vol 13(7–9), 1039–1072.
- Smith G.D. (1974), *Numerical Solution of Partial Differential Equations*, Oxford Mathematical Handbooks. Oxford University Press.
- Ten Raa T. (1986), *The initial value problem for the trade cycle in euclidean space*, Regional Science and Urban Economics, vol 16(4), 527–546.
- Wen G.C. and Zou B. (2000), *Initial-irregular oblique derivative problems for nonlinear parabolic complex equations of second order with measurable coefficients*, Nonlinear Analysis, TMA, 39,937–953.
- Wen G.C. and Zou B. (2002), *Initial-Boundary Value Problems for Nonlinear Parabolic Equations in Higher Dimensional Domains*, Science Press, Beijing/ New York.